



# BLIZZARD<sup>®</sup>

POWER PLOW



[www.blizzardplows.com](http://www.blizzardplows.com)

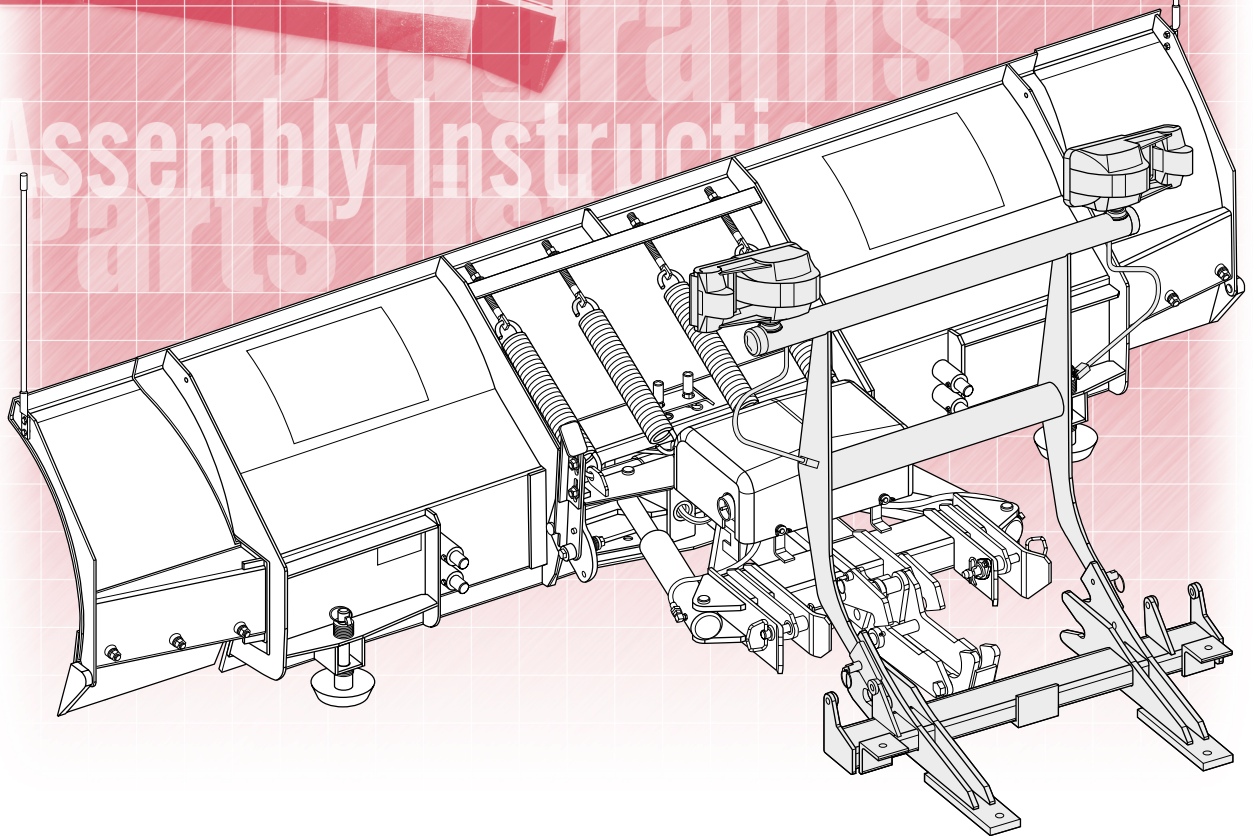

## 2003 Assembly & Operation Manual

Blizzard<sup>®</sup> Power Plow<sup>®</sup> Snowplow  
Model 810

## Introduction

Congratulations on purchasing the most advanced snowplow available! The Blizzard Power Plow snowplow is clearing new trails for innovative design, rugged durability, quality craftsmanship and superior performance. Our exclusive products are manufactured and tested in Michigan's Upper Peninsula, the snow capital of the Midwest. With an annual snowfall averaging over 250", we couldn't imagine building snow removal products anywhere else!

Your Blizzard Power Plow snowplow is equipped with versatile features designed for years of dependable service. The hydraulic draw latch mounting system positively aligns the plow for fast installation or removal. Twelve-inch expanding wings automatically transform a compact 8' blade into a massive 10' machine. Also, the independent wings can pivot forward to form our 9'-3" BucketBlade™ position. Now you can carry more snow even further. Safety features include full moldboard trip action, enclosed hydraulics and automatic cylinder pressure relief.

To ensure years of optimum snowplow performance, review the contents of this manual. It contains assembly information, detailed diagrams, complete parts listings, maintenance guidelines and troubleshooting tips.

Should you need additional information, contact your local Blizzard Power Plow snowplow dealer. Their knowledgeable staff is well informed on the latest Power Plow snowplow information. They are also your source for complete replacement parts, technical assistance and all service repairs.

Comments, suggestions or concerns?  
Address all correspondence to:

Blizzard Corporation  
Customer Service Department  
95 Airpark Boulevard  
Calumet, MI 49913

# Table of Contents

<b>01</b>	Snowplow Accessories
<b>02</b>	Warning!
<b>03</b>	Snowplow Operation
	<b>Assembly Instructions</b>
<b>04</b>	Unpacking & Inspection
<b>05</b>	Moldboard & A-frame Assembly
<b>10</b>	Electrical Assembly - Plow Harness
<b>11</b>	Electrical Assembly - Vehicle Harness
<b>14</b>	Testing The Snowplow
<b>16</b>	Power Hitch™ Instruction
<b>17</b>	Notes
	<b>Maintenance &amp; Plow Specifications</b>
<b>18</b>	Regular Maintenance
<b>19</b>	Storing Your Snowplow
<b>20</b>	Plow Specifications
	<b>Torque Specifications</b>
<b>21</b>	Bolts & Hydraulic Adapters
	<b>Plow Diagrams &amp; Part Lists</b>
<b>22</b>	Blizzard Power Plow® Snowplow Parts List - Model 810
<b>26</b>	Blizzard Power Plow® Snowplow Assembly Schematic - Model 810
<b>28</b>	Hydraulic Manifold Detail
	<b>Electrical Diagrams</b>
<b>29</b>	Coil Harness & Hydraulic Manifold Schematic
<b>30</b>	Plow Harness
<b>31</b>	Plow Harness Wire Schematic
<b>32</b>	Main Lighting Harness - Relay Version
<b>33</b>	Main Lighting Harness - Relay Version Wire Schematic
<b>34</b>	Vehicle Harness
<b>35</b>	Vehicle Harness Wire Schematic
<b>36</b>	Molded Plug Pin Locations
	<b>Troubleshooting</b>
<b>37</b>	Troubleshooting Guide
	<b>Warranties</b>
<b>40</b>	Limited Consumer Warranty
<b>41</b>	Commercial Warranty

# Snowplow Accessories

All of the accessories pictured below are currently offered for your snowplow. See your local authorized Blizzard dealer for pricing and availability. Visit [www.blizzardplows.com](http://www.blizzardplows.com) to view new snowplow accessories and the latest Blizzard snowplow wearables.

See page 25 for additional Power Plow snowplow accessories.



**Rocker Switch/Joystick Control Station**  
P/N 62109

Like the touch of our standard rocker switch control but want to control your Blizzard Power Plow snowplow with a joystick? Our optional control gives you the best of both with a 2-1/4" tall joystick

and wing operation rocker switches. Easily install the control using our Seat Cinch™ system—a Velcro® strap that wraps around the bench or vehicle console.



**Touch Pad Control Station**  
P/N 62141

Small and compact, the Power Plow snowplow touch pad control offers ergonomic comfort behind the wheel. Whether you hold it in your hand, strap it on your leg, wrap it around your seat or mount it to the dashboard, this control will

provide the flexibility you need! Control is shipped with a molded plastic leg tray, adjustable Velcro® strap and extra Velcro® patches. Measures 3-1/4" x 3-1/4" x 1-5/16".



**Adjustable Pedestal Mount**  
(For use with all controls)  
P/N 63078 (12" Shaft)

Easy-to-install and flexible, our adjustable pedestal mount will position your Power Plow snowplow control station how you want it! Available in a 12" extension, this quality built accessory will install

on either Blizzard Power Plow snowplow control station in minutes! Ideal for bucket seat vehicles with low center consoles. Pedestal accessory shipped with complete hardware and adapter plate.



**Blizzard Snowplows Emergency Parts Kit**  
P/N 63074

Be prepared for unexpected plow emergencies! This kit includes the most common replacement parts conveniently packaged in a small, durable plastic case. Custom foam insert holds the following plow

parts: Angle cylinder hose, lift cylinder hose, hitch pin w/hair pin cotter, angle cylinder clevis pin w/cotter, 90° angle cylinder fitting, solenoid, Power Hitch™ toggle switch, corrosion preventive compound (2 oz.) and 10A fuse. The compact case (13.5"x9"x3.3") allows for easy storage behind or under your truck seat.



**Rubber Snow Deflector**  
P/N 61241

Plow safer and easier with our custom rubber snow deflector. This easy-to-install accessory keeps snow off of your windshield and in its place—on the ground! Rugged and durable, the 3/8" thick, 2-ply construction is made

to last. The one piece rubber design allows for wing clearance and provides optimum snow deflection. The deflector is shipped with a "Blizzard Power Plow" vinyl decal and complete mounting hardware.



**Blizzard Snowplow Airfoil**  
P/N 52093

Help channel air flow to your truck radiator during the long haul over the road. Mounted front and center, our custom airfoil redirects air over the top of the blade and into the grill of your vehicle. Don't get stuck on the side of the road! Keep

trucking with this easy-to-install accessory. The airfoil is shipped with complete mounting hardware.

# Warning!



## WARNING:

Prior to operating your Power Plow snowplow, review the WARNING! label at the passenger's side rear of the moldboard (shown below).



## CAUTION:

*Note: Read and understand all warnings indicated in this manual prior to operating the snowplow. Warnings and cautions in the manual are indicated by the icons shown to the left.*

# WARNING

1. Properly mount the snowplow prior to moving the vehicle.
2. To prevent accidental plow activation, turn the Power switch on the snowplow control to the "OFF" position when not in use.
3. Stand clear of the attachment area when mounting the snowplow to the undercarriage and operating the Power Hitch Connect/Disconnect switch. Failure to do so may result in serious injury or death.
4. Securely position all mounting pins prior to operating your snowplow.
5. Do not position your body between the snowplow and the vehicle when servicing or operating.
6. Position the snowplow in such a manner as to not block your vision or plow lights while in transit.
7. Always travel with the wings fully retracted. Depending on local and state regulations, you may be exceeding the legal vehicle width when the wings are fully or partially extended.
8. Do not change the position of the snowplow while in transit.
9. Do not exceed 40 mph when transporting the snowplow.
10. Do not exceed 10 mph when plowing.
11. Always lower the snowplow when the vehicle is parked.
12. Vehicles equipped with air bags are designed to be activated in a frontal collision equivalent to hitting a solid object or barrier at approximately 14 mph or more.

### WARNING

Careless or high speed driving while plowing snow, which results in vehicle impact deceleration equivalent to or greater than the airbag deployment threshold described above, would deploy the airbag.

The Blizzard Power Plow snowplow is protected by U.S. Patents 5,899,007; 5,638,618 and 6,276,076 B1. Other patents pending.

Do not exceed the (GVWR) Gross Vehicle Weight Rating or (GAWR) Gross Axle Weight Rating including the snowplow and ballast. Refer to your vehicle Owner's Manual for the proper weight ratings.

READ  
OWNER'S  
MANUAL  
THOROUGHLY  
PRIOR TO  
OPERATING  
PLOW.

 **BLIZZARD**<sup>®</sup>  
CORPORATION

Calumet, MI 49913

BLZ 1005

Should the WARNING! label or any of the labels that came with your snowplow become hard to read or wear off, contact your local authorized Blizzard dealer for replacements.

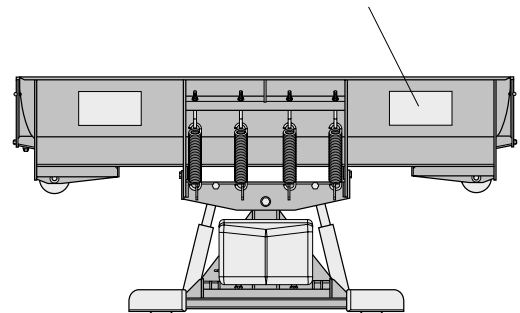

# Snowplow Operation

Your Blizzard Power Plow snowplow is the most advanced and versatile snowplow on the market. The easy-to-use controls allow you to automatically adjust the plow blade and wings into an infinite number of plowing positions. Review the illustrations below to determine the best position for your plowing needs.

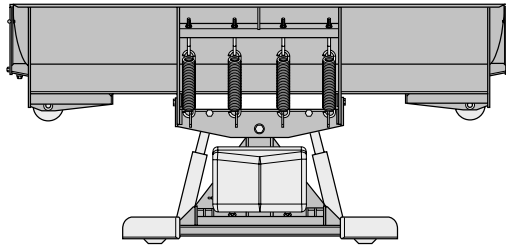

A.

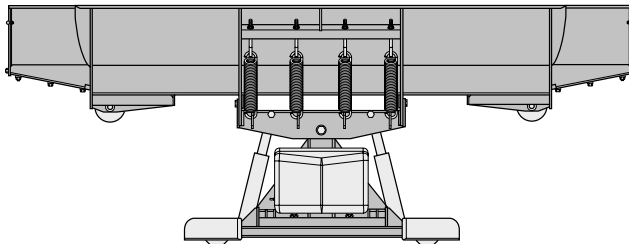

B.

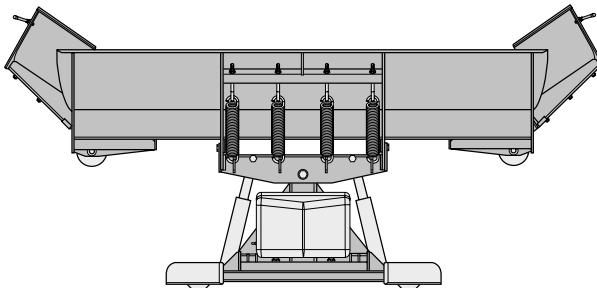

C.

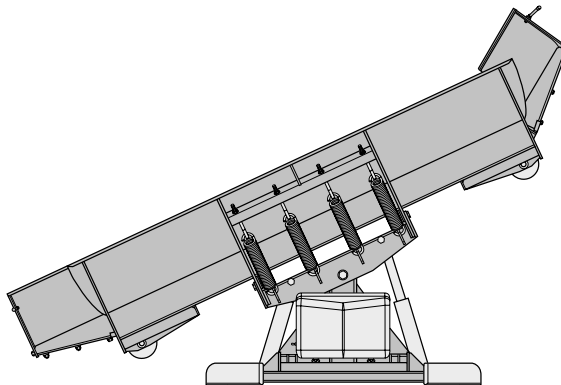

D.

## A. Compact Position (8' Blade Width)

- Primary position when transporting the snowplow
- For use in heavy snow conditions with poor visibility, initial clearing and tight quarters
- *Ideal application: Residential driveways, small roads*

## B. WidePass™ Position (10' Blade Width)

- Primary position for clearing large surfaces
- For use in light snow conditions with good visibility, final clearing and clean-up
- *Ideal application: Large parking lots, widening roadways*

## C. BucketBlade™ Position (9'-3" Blade Width)

- Primary position for transporting snow
- For use in initial clearing with decent visibility, transporting large volumes of snow, final clean-up
- *Ideal application: Roadway intersections*

## D. WidePass™ Position Angled with Wing Forward

- Primary position for accelerated angled plowing
- For use in directional plowing, cornering, diverting snow away from objects or buildings
- *Ideal application: Plowing adjacent to buildings, driveway/road intersections*

### \*\*\*\* IMPORTANT \*\*\*\*

To prevent premature failure of the power contactor (solenoid), initiate the plow function and return the rocker switch and/or joystick to its neutral or center position. **DO NOT** hold a rocker switch and/or joystick in any position that allows the pump to continuously run after the main blade or wing has reached its maximum degree of movement. This will reduce the useful life of the solenoid.

# Assembly Instructions

## Unpacking & Inspection

\_\_\_\_\_  
Date of Purchase

\_\_\_\_\_  
Dealer/Distributor

\_\_\_\_\_  
Telephone Number

\_\_\_\_\_  
Snowplow Serial Number

\_\_\_\_\_  
Hydraulic Pump Serial Number

Your Blizzard Power Plow snowplow has been packaged to withstand transit and weather related damage. Fully inspect all components upon receipt of your plow. In the event of shipping damage or missing parts, immediately contact our Customer Service Department at 1-888-680-8600.

Begin unpacking and inspection in the following order:

1. Remove the shipping document from the end panel of the pallet wrap. Retain all documentation for your records.
2. All wood framing and polyethylene material should be removed from the pallet for easy access to the snowplow.
3. Due to the odd shaped components and size of several assembly parts, various cable ties and corrugated material are used for scratch resistance and package orientation. Please remove these items prior to assembly.
4. Place the main blade assembly on a flat, level surface.

Once you have inspected all parts and removed all packaging materials, your snowplow is ready to be fully assembled.

### Pallet Wrap End Panel

The tear-resistant, woven polyethylene pallet wrap contains a moisture barrier to help protect all packaged components and keep out the most inclement weather during shipping and storage. The end panel of the pallet cover contains important information regarding the snowplow model and the plow's serial number. Both of these numbers are given together. The first three digits of the number indicated is always the plow model – 810 and the entire number is the serial number (Example 810-00001). The shipping document is also attached to the end panel. Be sure to retain this list for your records.

*THIS SIDE UP* ▲

**SHIPPING INFORMATION AND PACKAGING CONTENTS**

<b>PACKAGING LIST</b> 	<b>MAKE:</b> <input type="checkbox"/> FORD <input type="checkbox"/> GMC/CHEVY <input type="checkbox"/> DODGE <input type="checkbox"/> OTHER _____	
	<b>MODEL:</b> <input type="checkbox"/> GAS <input type="checkbox"/> DIESEL _____	<b>YEAR:</b> _____
	<b>PLOW MODEL:</b> _____	

U.S. PATENT NO. 5,638,610 U.S. PATENT NO. 5,899,007 OTHER PATENTS PENDING



BLIZZARD™  
POWER PLOW

*MADE IN THE U.S.A.*

POWER HITCH



FORKLIFT POINTS ▼

# Moldboard & A-Frame Assembly

1. Begin the moldboard assembly by first removing each dust cap from both of the SLIDE BOX CYLINDERS located at the center/rear of the MOLDBOARD. Attach one 7/16"-20 x 9/16"-18 MALE O.R.B. CONNECTOR to each of the retract ports (#7 & #10) and one 9/16"-18 x 9/16"-18 MALE O.R.B. CONNECTOR to each of the extend ports (#8 & #9). Review the diagram below. *Note: All of the hydraulic adapters can be found packaged with the manifold assembly. Reference the table on page 21 for proper torque specifications.*

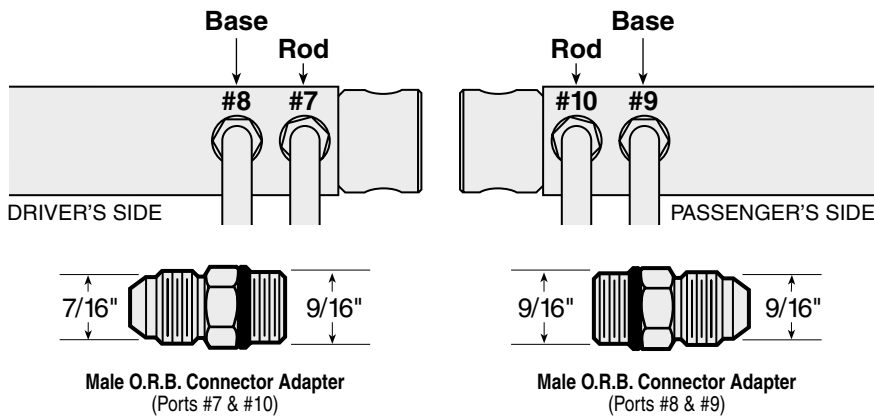

2. Connect the hoses to each of the hydraulic adapters on the cylinders. Ports #7 & #10 receive a 1/4" x 36" HYDRAULIC HOSE (P/N 60019). *Note: Review the label on each hose for the appropriate part number.* Ports #8 & #9 receive a 3/8" x 36" HYDRAULIC HOSE (P/N 60224).
3. Next, position the PIVOT BEAM and the A-FRAME, near the mount locations at the rear of the blade, between the two center support ribs. Place the right and left group of hydraulic hoses (connected to the slide box cylinders) through the 1-1/2" diameter rubber grommet openings in the front face of the pivot beam. See the diagram to the right.
4. Position the pivot beam between the two support ribs until the connecting points on the beam align with those on the plow. Insert one 3/4" DIA. x 3" CLEVIS PIN through each mounting hole and secure them with one 1/4" DIA. x 1-1/2" COTTER PIN.

*Note: Mount the kickstand to the end of the pivot beam (driver's side) using the 1/2"-13 x 4-1/2" bolt provided. The spring, bushing and lock nut locate on the inside of the pivot beam. Review the diagram to the right and on page 26. Upon installation, rotate the spring loaded kickstand clockwise until it locks into place. Adjust the foot on the stand arm so the height of the A-frame, at its mount points, is 12-1/2" to level ground. Tighten both of the 1/2"-13 top lock nuts on the kickstand.*

*Note: To prevent the kickstand from hitting the ground before the snowplow cutting edges, causing stress on the kickstand lock pin, adjust the kickstand foot approximately 1/8" short of level ground. This procedure will provide clearance for the kickstand when the snowplow is lowered with the kickstand in the down position.*

5. Position each ANGLE CYLINDER with the rod end of the cylinder in the pivot beam and the hydraulic hose port facing away from the

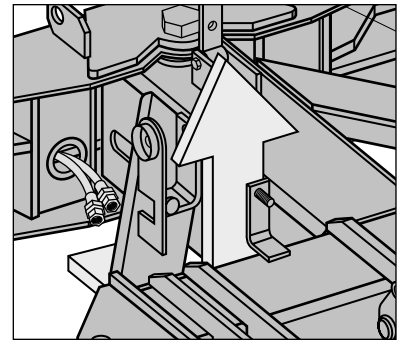

Feed each group of hoses (two per side) through the grommets in the pivot beam and up through the openings in the A-frame. Positioning the hoses through the pivot beam supports the hoses while the snowplow is in use and prevents them from dragging on the ground.

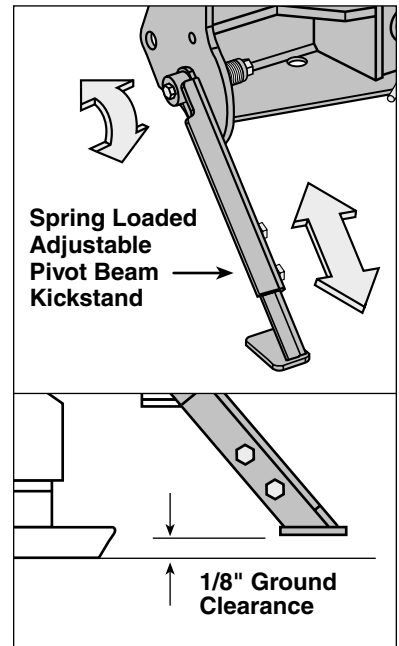
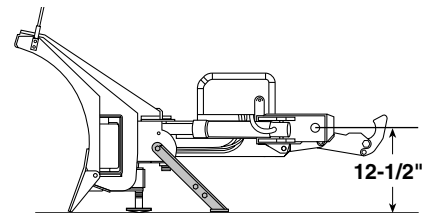

The kickstand mounts to the side of the pivot beam with one 1/2"-13 x 4-1/2" hex cap screw and top lock nut. To pivot the kickstand, simply pull the spring loaded leg out and rotate it until the pin locks into place. The kickstand also has an adjustable foot that can be moved to accommodate varying vehicle heights. Adjust the kickstand foot approximately 1/8" short of level ground. This will prevent the kickstand from hitting the ground before the plow cutting edges. The proper height of your snowplow mounting points to level ground should be set at 12-1/2".

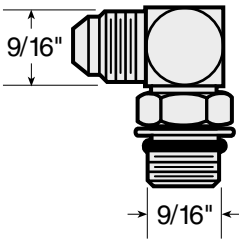

90° Adjustable Elbow O.R.B. Adapter

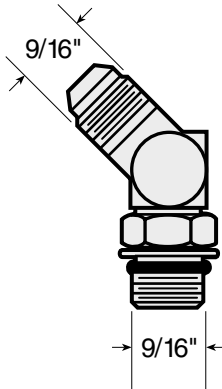

45° Adjustable Elbow O.R.B. Adapter



Male O.R.B. Connector Adapter

A-frame. Secure the cylinder to the pivot beam with one 3/4" x 5" CLEVIS PIN and one 1/4" x 1-1/2" cotter pin. Extend each cylinder rod until the cylinder base mounting hole aligns with the hole on the A-frame angle cylinder bracket. At this point, insert another clevis pin and secure it with a cotter pin. Repeat the same installation for the opposite angle cylinder.

- Remove each dust cap from both of the hydraulic angle cylinder ports and attach one 9/16"-18 x 9/16"-18 90° ADJUSTABLE ELBOW O.R.B. ADAPTER to each port. Each adapter should be angled toward the top of the moldboard. Connect one 3/8" x 24" hydraulic hose (P/N 60091) to each angle cylinder adapter. Be careful not to overtighten the hose connections. Route both hoses over the TOP of each angle cylinder. This will prevent them from hanging or being pinched.
- Next, remove both of the plastic dust caps from the HYDRAULIC LIFT CYLINDER ports. Attach one 9/16"-18 x 9/16"-18 45° ADJUSTABLE ELBOW O.R.B. ADAPTER to the driver's side port (base end) and one 9/16"-18 x 9/16"-18 MALE O.R.B. CONNECTOR ADAPTER to the passenger's side port (rod end). Once the adapters have been installed on the cylinder, connect the hydraulic hoses. *Note: Position the 45° fitting in the cylinder port such that the hoses install directly in the center of the A-frame access holes. A hose installed too close to the edge of the opening may work itself free with the operation of the lift cylinder and/or movement of the plow.* The 45° adapter receives a 3/8" x 17" hydraulic hose (P/N 60273). Connect the 45° angle on the hose to the hydraulic adapter on the cylinder. The male connector adapter receives a 3/8" x 15" hydraulic hose (P/N 60274). Tighten the 45° end of the hose to the hydraulic adapter on the cylinder. Both hoses should be routed through the triangular openings in the A-frame.

#### Draw Latch Assembly

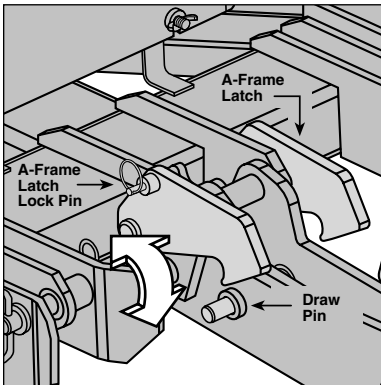

To mount the Power Plow snowplow, the A-frame latch should be lowered over the draw pin—this allows the draw latch to pull the plow into the undercarriage. Once the plow is safely attached to the undercarriage, rotate the A-frame latch counterclockwise until the lock pin snaps into place. The A-frame latch is only used to mount the plow. **Do not allow the lock pin to set behind the pin catch hole in the raised position. The A-frame latch should always be locked in place when not in use.**

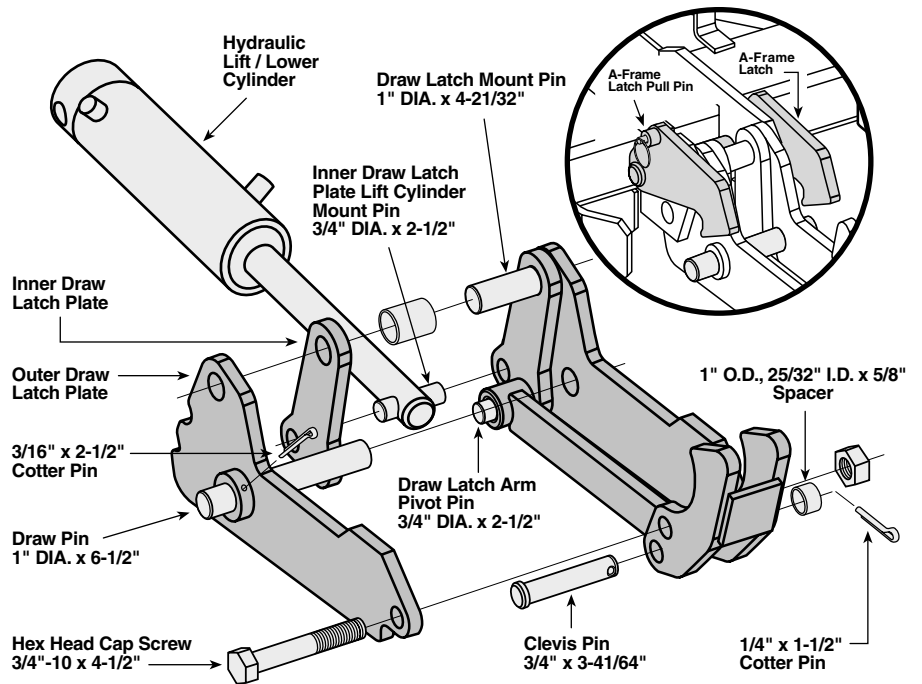

- Begin the draw latch installation by first removing the DRAW LATCH MOUNT PIN & SPACER from the assembly. By removing this pin, the INNER DRAW LATCH PLATES can swing free. Proceed to remove the INNER DRAW LATCH PLATE LIFT CYLINDER MOUNT PIN.



Position the plates on either side of the lift/lower cylinder rod and insert the pin through the plates and cylinder rod. With the cylinder connected to the inner draw latch plates, rotate the draw latch assembly toward the inner draw latch plates, rotate the draw latch assembly toward the draw latch mount holes on the A-frame. Align the holes in the outer draw latch plate with those of the inner draw latch plates and the A-frame. *Note: The A-FRAME LATCH, located at the rear center of the A-frame, should be raised up to insert the draw latch mount pin. Pull the A-FRAME LATCH PULL PIN out and rotate the latch counter-clockwise if it is locked into position. Secure the assembly to the A-frame by replacing the draw latch mount pin and spacer. Reset the A-frame latch so the A-frame latch pull pin locks into place.*

Once you have completed the draw latch installation, proceed to assemble the manifold. The manifold, pump and coil harness have been joined together at the factory; however, the manifold contains several components that you will need to install prior to securing the assembly to the A-frame.

- Each of the 8 HOSE PORTS on the HYDRAULIC MANIFOLD are covered with stretch wrap. Remove the wrap and install the appropriate fitting (illustrated below) in its respective port.

*Note: All ports are identified by a stamped number on the manifold. The numbers also identify the hydraulic functions, which can be referenced on the label under the hydraulic pump and manifold cover (see illustration on page 8).*

*Note: The gray arrows shown on the manifold illustration below indicate the direction the 90° adapters should face to receive the hydraulic hoses.*

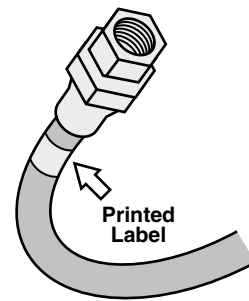

All of the hoses shipped with the snowplow contain a printed label (with a part number) applied to the hose. Install the following hoses to their respective ports on the manifold:

- Hose P/N 60091 Ports #1 & #2
  - Hose P/N 60273 Port #3
  - Hose P/N 60274 Port #4
  - Hose P/N 60019 Ports #7 & #10\*
  - Hose P/N 60224 Ports #8 & #9\*
- Note: See diagram on page 8.

#### Installing The Manifold Adapters

There are a total of 18 hydraulic adapters to install. All of the adapters can be found packaged with the manifold assembly. Remove the protective stretch wrap from the manifold in a clean area. **DO NOT** let any foreign objects enter into the open ports. The valves can become contaminated and greatly hinder the plow's performance. Review the table on page 21 for proper torque specifications.

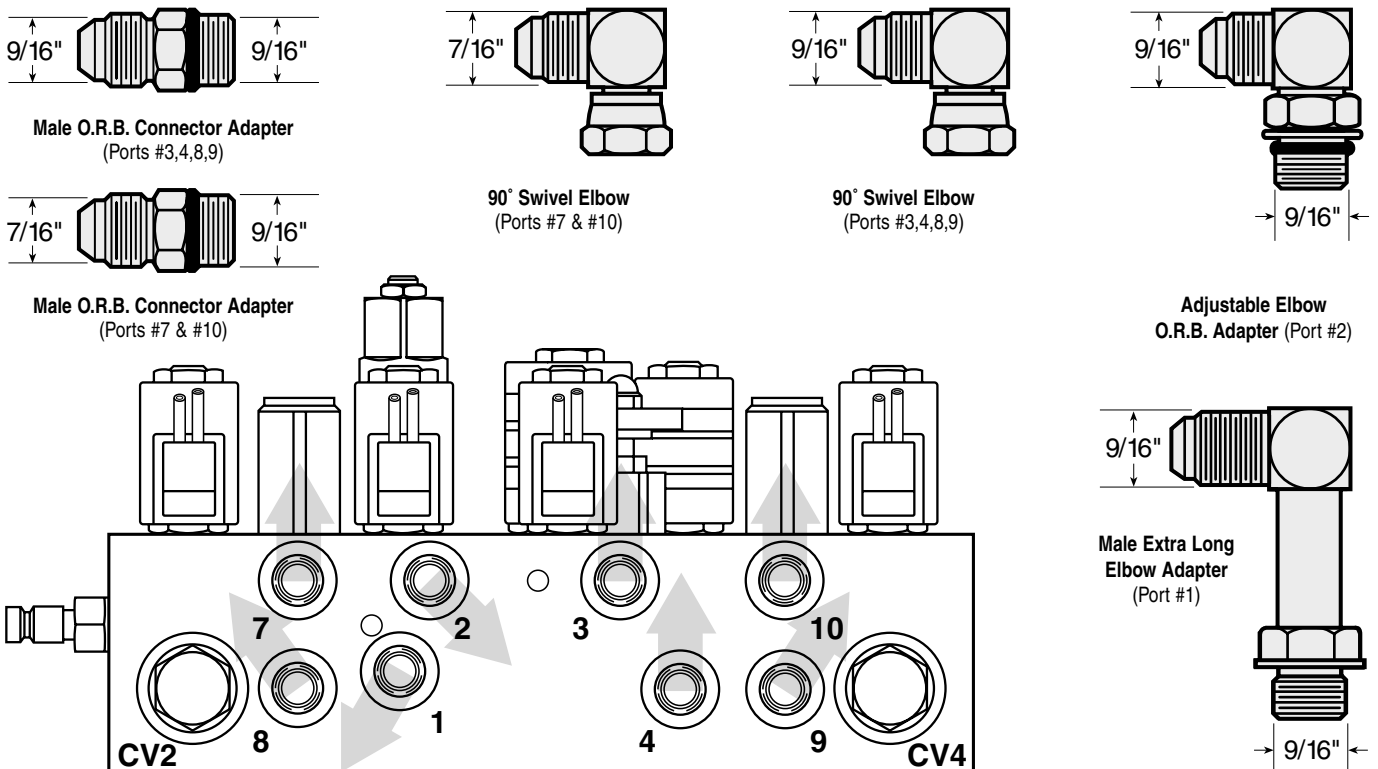

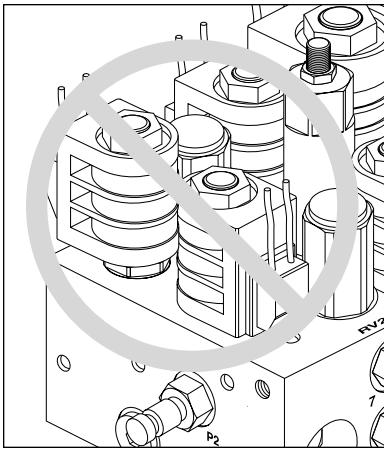

When installing the manifold between the mount brackets on the A-frame, **DO NOT** handle the manifold by the coils. The solenoid cartridges can bend, causing them to stick when activated. Always carry the manifold by the sides of the aluminum block.

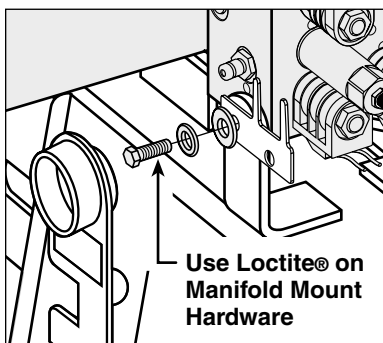
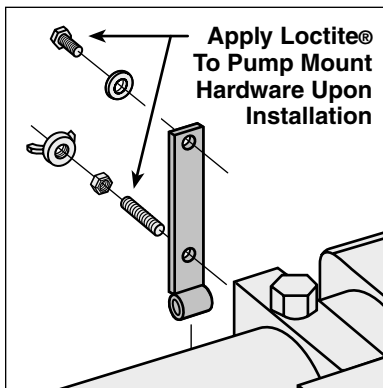

A medium strength threadlocker, such as Loctite® 242®, should be used to properly secure the mount hardware for the pump and manifold. This will help prevent the hardware from working free from vibration and plow use. Apply a liberal amount of threadlocker to both threaded fasteners and the threads in the pump (top diagram). The manifold receives two 3/8"-16 x 1-1/4" hex cap screws—one on each side of the A-frame. Likewise, use threadlocker on these fasteners and the tapped holes in the manifold (bottom diagram).

- Next, align the mount holes in the pump with the holes in the hinged bracket, located on the A-frame. *Note: To help facilitate the pump mount, first angle the hinged bracket as needed and tighten the bracket hardware, locking it in place.*



**CAUTION:** When installing the manifold between the mount brackets on the A-frame, hold the manifold at the sides of the block. Never handle the manifold by coils. Doing so can cause a solenoid cartridge to bend, causing the cartridge to stick when activated.

Secure one 3/8"-16 x 3/4" hex head cap screw and 3/8" flat washer through the top mount hole in the bracket and into the pump. Insert one 3/8"-16 x 1-3/4" threaded stud and 3/8"-16 jam nylon insert lock nut through the bottom mount hole in the bracket and into the pump. The threaded stud should bottom out in the pump. *Note: A medium strength threadlocker, such as Loctite® 242® should be used on both of the pump mount fasteners. This will help prevent the fasteners from working free.*

## Sequence Valve & Hydraulic Hose Identification Guide

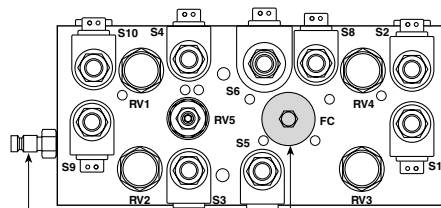

Pressure Gauge Quick Connect      Clockwise - Decreases Plow Drop Speed  
Counterclockwise - Increases Plow Drop Speed

NOTE: Check valves CV1 & CV3 are not illustrated. Both valves are located on the opposite side of the manifold in the diagram shown below.

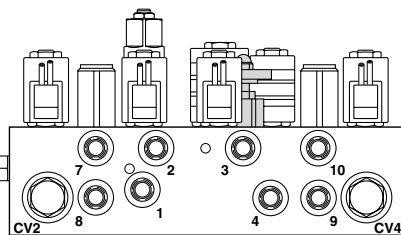

HYDRAULIC HOSES	
Port	Function
1	Right Angle - Left Cylinder
2	Left Angle - Right Cylinder
3	Raise - Lift Cylinder (Base)
4	Lower - Lift Cylinder (Rod)
7	Left Slide Box Retract
8	Left Slide Box Extend
9	Right Slide Box Extend
10	Right Slide Box Retract
RELIEF & CHECK VALVES	
Valve	Function
RV1	Left Wing Pressure Relief
RV2	Left Wing Anti-Cavitation
RV3	Right Wing Anti-Cavitation
RV4	Right Wing Pressure Relief
RV5	Angle Relief
CV1	Left Wing Check Valve
CV2	Left Slide Box Check Valve
CV3	Right Wing Check Valve
CV4	Right Slide Box Check Valve
VARIABLE FLOW CONTROL VALVE	
FC	Adjustable Plow Drop Speed
NOTE: Energize the following solenoids for the functions:	
S1	Right Slide Box Retract
S2	Right Slide Box Extend
S3	Angle Left - Right Cylinder
S4	Angle Right - Left Cylinder
S5	Float
S6	Raise
S5 & S8	Lower
S9	Left Slide Box Retract
S10	Left Slide Box Extend

**BLIZZARD**  
CORPORATION

Calumet, Michigan 49913      BLZ 1055

- Once the pump and manifold assembly is in place, connect the hydraulic hoses to their respective adapters on the manifold. Review the label under the pump cover to identify which hoses connect to each port. *Note: All hoses, except #1 & #2 (angle cylinders) should be routed through the triangular openings in the A-frame. Position these hoses over the A-frame angle and to their respective manifold ports.* Note the positions for the rod- and base-end slide box hoses. The hoses that operate the retract functions (rod) of the cylinders are closest to the base of each cylinder. Likewise, the hoses that operate the extend functions (base) of the cylinders are closest to the rod of each cylinder. Review the diagram on page 5 and the hose installation list on page 7.

12. Next, secure the manifold to the A-frame. Remove both 3/8" flat washers, 3/8" split lock washers and 3/8"-16 x 1-1/4" hex head cap screws from the manifold and align the mount holes with the A-frame brackets. Position the DIODE PACK MOUNT BRACKET against the outside of the A-frame bracket on the driver's side. *Note: Both of the prongs should be facing up.* Align the outside hole on the diode bracket with the holes on the A-frame and manifold. Properly replace and tighten all hardware. *Note: A medium strength threadlocker, such as Loctite® 242® should be used to secure the manifold mount fasteners.*
13. Hook each EXTENSION SPRING to the receiving holes located on the pivot beam and connect the opposite end of the spring to their respective SPADE BOLTS. Install the 5/8"-11 x 6-3/8" spade bolts through the EXTENSION SPRING MOUNTING ANGLE on the top rear of the blade. Secure each spade bolt by placing one 5/8" flat washer on the bolt and thread one 5/8"-11 nylon insert lock nut. Tighten each lock nut until a piece of paper can pass between the 3th & 4th coils on the spring.
14. Install the flexible BLADE GUIDES at each end of the moldboard. Insert the 5/16"-18 x 1" hex head cap screw through the holes at the top of the wing reinforcement rib. Tighten all screws using the nylon insert lock nuts provided.

Congratulations! You have successfully completed half of the installation. Don't quit now, you're nearly out of the garage!

## Electrical Assembly - Plow Harness

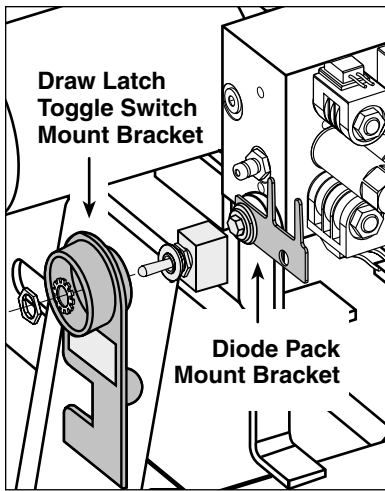

The diode pack (on the plow harness) clips onto the diode pack mount bracket. Place a cable tie through the hole at the end of the bracket and over the pack to secure it in place.

The draw latch toggle switch installs through the rear of the bracket with the protective hood. Align the key washer with the slot cut in the bracket to prevent the switch from turning. Secure the switch with the hardware provided. Note: Use the square notch in the bracket (below the protective hood) to position the braided harness. Use another cable tie to hold the harness against the bracket.

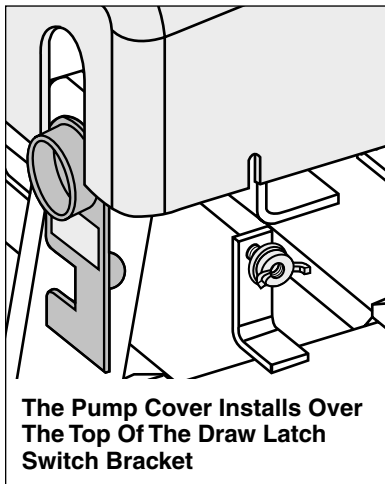

**The Pump Cover Installs Over The Top Of The Draw Latch Switch Bracket**

To properly secure the pump and manifold cover on the A-frame, position the cover over the top of the protective hood on the draw latch switch mount bracket. Align the slots in the cover with the welded bolts on the A-frame brackets—secure the cover using three flanged wing nuts.

1. Begin the electrical assembly by connecting the RED POWER WIRE from the PLOW ELECTRICAL HARNESS to the PUMP motor terminal stud using the hardware provided on the pump.
2. Place one 3/8" INTERNAL/EXTERNAL TOOTH LOCK WASHER, the BLACK GROUND WIRE (from the harness) and the RED GROUND WIRE on the COIL WIRE HARNESS (from the manifold) over the tapped hole on the pump and secure the ground using one 3/8"-16 x 3/4" hex head cap screw.
3. Remove the hex jam nut and external tooth lock washer from the POWER HITCH CONNECT/DISCONNECT TOGGLE SWITCH and insert it through the back of the mounting bracket on the A-frame. Align the notch in the key washer on the switch to the notch on the bracket. Replace the lock washer and jam nut and tighten until the switch is firmly in place. Next, attach the connector on the plow harness to the switch. *Note: Use caution when making the connection. Switches can break if done forcefully.*
4. Continue the harness installation by connecting the PLASTIC FEMALE ELECTRICAL CONNECTOR on the harness to the PLASTIC MALE ELECTRICAL CONNECTOR found on the coil wire harness.
5. Finalize the harness installation by sliding the DIODE PACK over the diode pack mount bracket located behind the connect/disconnect toggle switch. Position the wire harness braid in the notch on the switch bracket and secure it with a cable tie. The diode pack mount bracket contains an extra hole for a cable tie. Use it to secure the diode pack.
6. To install the PUMP & MANIFOLD COVER, align the notches in the cover with the welded bolts on the A-frame brackets. Secure the cover with two 3/8" FLANGED WING NUTS. Verify the cover is positioned over the protective toggle switch hood. Pop the front of the cover on the threaded stud and secure it with the remaining wing nut.

Congratulations! You have just completed building the finest snowplow available! However, the vehicle wire harness still needs to be installed. That is the focus of the second half of the electrical assembly instruction.

# Electrical Assembly - Vehicle Harness



**CAUTION:** Always perform the vehicle wire harness assembly with the vehicle off and the keys out of the ignition. Use caution when testing the electrical wires for the vehicle's headlight functions.

1. Begin the installation of the electrical harness under the hood. Insert the WHITE POWER CONNECTOR & RED POWER WIRE (with FUSE) end of the harness through the driver's side fire wall access panel into the vehicle cab. *Note: You may need to widen an opening or cut access to the cab interior to facilitate the assembly.* Loosely position the remaining portion of the harness over the driver's side fender well and place the MOLDED RUBBER POWER CONNECTOR near the bumper. *Note: Keep the plow and vehicle rubber power connector pins lubricated with a liberal amount of dielectric grease. Always replace the protective RUBBER WEATHER CAPS when the plow is disconnected from the vehicle.*
2. Next, attach the POWER CONTACTOR (SOLENOID) to the driver's side wheel well or engine fan guard using two 12-14 x 3/4" hex washer self-drilling screws. *Note: Some model vehicles provide mounting locations for accessory components. Always mount the solenoid with the terminals facing up. This will extend the useful life of the solenoid.* Connect the 24" BLACK GROUND WIRE to either small terminal on the solenoid and attach the opposite end to the vehicle with one hex washer self-drilling screw. Locate the BROWN/WHITE PUMP SOLENOID ACTIVATION WIRE on the wire harness and position the eyelet over the remaining small terminal on the contactor. Secure it with the hardware provided on the solenoid.
3. Proceed to connect the BLACK VEHICLE WIRE HARNESS GROUND WIRE to the negative terminal on the vehicle's battery. Cut the wire to length and crimp a 3/8" DIA. END RING TERMINAL on the wire. It is also recommended that the ring terminal be soldered. *Note: The harness should be secured to the vehicle prior to taking the necessary measurement.* Measure the distance needed for the RED POWER WIRE to reach the solenoid and properly secure an end ring terminal to it. Connect the power wire to either large terminal on the solenoid.



**CAUTION:** Do not fasten the wire harness to areas that come in contact with moving engine parts or possess extreme heat. The harness could become tangled and/or melt causing electrical failure and vehicle damage.

4. Attach and solder an end ring terminal to both ends of the remaining length of the red 4 gauge wire. Connect one end of the wire to the open terminal on the solenoid and the remaining end to the positive terminal on the battery.
5. With the vehicle harness secured to the truck, position the MAIN LIGHTING HARNESS such that both of the large, gray VEHICLE HEADLIGHT CONNECTORS are near the truck headlights and the smaller, black PLOW HEADLIGHT CONNECTORS are near the grill of the vehicle.

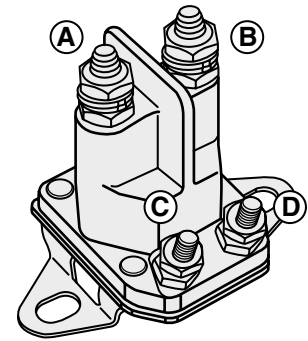

**Heavy-Duty Power Contactor (Solenoid)**

There are four wires that need to be attached to the power contactor:

- (A) Red Power Battery Wire
- (B) Vehicle Wire Harness Red Power Wire
- (C) 24" Black Ground Wire
- (D) Brown/White Pump Solenoid Activation Wire

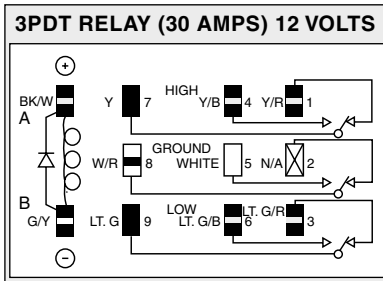
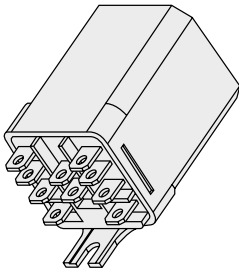

Connect the color coded wires from the vehicle harness to the headlight relay shown above. The wires correspond to the numbers/letters on the relay or the color abbreviations on the illustration.

- (A) BK/W = Black/White Wire
- (B) G/Y = Green/Yellow Wire
- (1) Y/R = Yellow/Red Wire
- (2) N/A = Not Applicable
- (3) LT.G/R = Light Green/Red Wire
- (4) Y/B = Yellow/Black
- (5) W = White
- (6) LT.G/B = Light Green/Black
- (7) Y = Yellow
- (8) W/R = White/Red Wire
- (9) LT.G = Light Green

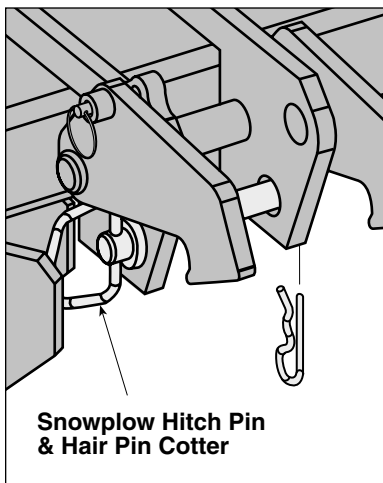

In the event you should lose hydraulic power while snowplowing, raise the snowplow into a pile of snow and insert one of the two hitch pins provided with your plow. The pin will lock the plow in a temporary raised position until proper service can be performed to restore hydraulic power. Note: For clarity, the draw latch is not illustrated.

6. Plug the 9 TERMINALS, from the main lighting harness, into the HEADLIGHT RELAY. See the illustration to the left. Connect the GREEN & YELLOW wire, from the vehicle harness with the molded power plug, to the remaining spade on the relay. Securely mount the relay to the vehicle with the terminals facing down. Installing the relay in this position will allow moisture to drain from the relay.
7. Next, remove the front directional light assembly on the driver's side of the vehicle. Feed the VIOLET, turn light wire and GRAY, run light wire from the main lighting harness through the opening in the directional light housing. At this point, use a test light or ohm meter to determine the proper wires in the vehicle's electrical system to splice into. Once you have identified the proper wires, position one end of the turn or run light wire into a SPLICE LOCK CONNECTOR provided. Attach the vehicle wire to the opposite side of the splice lock connector. Complete the splice by pinching both wires together and locking the connector. Repeat the splice procedure for the remaining wire. The passenger's side directional light assembly requires the same installation; however, only one wire, the PINK, turn light, needs to be spliced.
8. Connect the vehicle headlights to the main lighting harness using a HEADLIGHT ADAPTER KIT. Due to differences in the construction of the adapter kits, and the various make and model vehicles Blizzard snowplows are installed on, a headlight adapter kit is not packaged with your snowplow. Contact your local Blizzard dealer to obtain the appropriate adapter for your vehicle.
9. Begin the adapter kit installation by removing the existing vehicle headlight connector from the headlight. Attach the HEADLIGHT ADAPTER CONNECTOR to the existing vehicle headlight connector. Next, plug the BLACK, FIVE-PIN CONNECTOR on the headlight adapter into the gray, five-pin connector on the vehicle wire harness. Lastly, plug the HEADLIGHT ADAPTER CONNECTOR into the vehicle headlight receptacle. *Note: If more than one plug is present, match the colors of each connector (ie gray to gray, black to black, Chevrolet daylight running is clear to gray).* Repeat the installation for the opposite headlight.
10. Once the headlight adapter connections are completed, proceed to secure the braided harness to the vehicle. Safely route all harness lengths around the engine components and attach them to the vehicle with cable ties. Extend the PLOW HEADLIGHT CONNECTORS, from the main lighting harness, through the grill of the vehicle and position the HARNESS POWER PLUG and WEATHER CAP near the bumper. Cable tie the power plug to the vehicle bumper or tow hook to keep the harness from hanging too low.
11. Return to the driver's side cab interior to install the remainder of the vehicle wire harness. Connect the RED POWER WIRE (with 10 AMP FUSE) to a switched power source with a minimum of 10 amps. *Note: The red power wire MUST be fused and switched on and off with ignition.* Secure all loose wires under the dash.
12. Next, install the LIGHT TOWER. Position the tower arms into the receiving pockets located on the undercarriage. Each pocket has a lock pin that secures both light tower arms. Pull out and twist each handle to temporarily unlock the pins. Place the light tower into the pockets and relock the pins.

See your local Blizzard dealer for complete installation instructions for your vehicle undercarriage.

- Proceed to install the PLOW HEADLIGHTS. Align one HEADLIGHT BALL STUD MOUNT ADAPTER on the light tower tube with the mounting hole and insert the threaded stud through each. Secure the headlight with one 7/16" external tooth lock washer and hex nut. *Note: All snowplows are shipped with two BLACK VINYL CAPS that install at either end of the light tower. Connect the terminals from the plow lights to the terminals on the main lighting harness. Repeat the installation for the opposite headlight.*

- Next, position the ROCKER SWITCH CONTROL STATION on the front radius of the seat. Wrap the VELCRO® STRAP around the bench, through the 2" metal D-ring and fasten. Finally, connect the white power connector from the vehicle wire harness to the connector on the control station. The power switch should be in the "MIDDLE" or "OFF" position. *Note: The operation of the draw latch can only be controlled when the power switch is located in the "UP" position and the "RAISE/LOWER" rocker switch is in the neutral or center position. See the diagram below.*

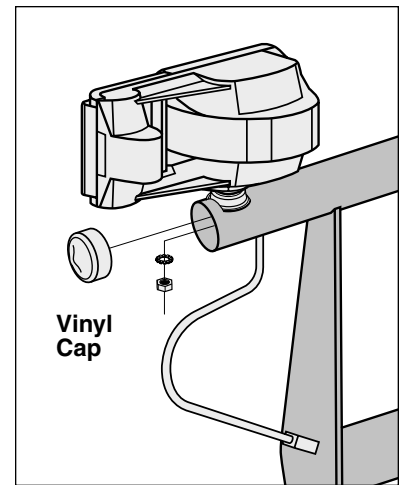

The black vinyl caps provided with your snowplow install at each end of the light tower. Adjust the plow headlights as desired, secure each with hardware provided and finish the installation by capping the light tower ends.

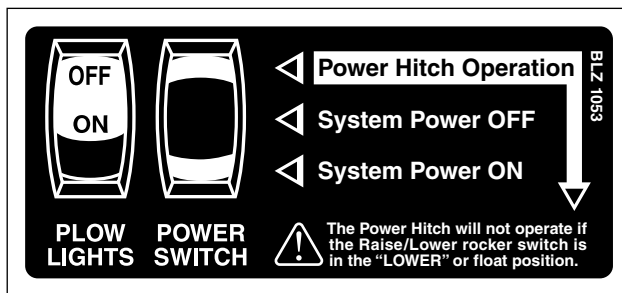

This completes the electrical assembly installation for the vehicle wire harness and main lighting harness. You are now ready to perform all of the test functions on the snowplow.



Your Blizzard Power Plow snowplow will use approximately 4 quarts of Blizzard Rapid Action Hydraulic Oil. *Note: The part number issued on the quart bottle label has been changed to P/N 63070. Blizzard hydraulic oil is also available by the case (P/N 63071), gallon (P/N 63072) or gallon case (P/N 63069). See your local authorized Blizzard dealer for price and availability.*

## Testing The Snowplow

1. Fill the HYDRAULIC PUMP FLUID RESERVOIR with BLIZZARD SNOWPLOW RAPID ACTION HYDRAULIC OIL (P/N 63070) until it is approximately 3/4" from the top of the tank. Replace the cap on the reservoir. Proceed to remove the weather caps from each of the plow and vehicle wire harnesses and connect the plugs. Start the vehicle and turn the POWER SWITCH on the control station in the cab to the "ON" position. You now have power to the snowplow. Once all of the hydraulic functions have been executed, the system will have been filled with approximately four quarts of hydraulic oil.
2. To raise the POWER HITCH on the snowplow, turn the power switch on the control station to the "UP" or "ON" position. Note: The "RAISE/LOWER" rocker switch must be in the neutral or center position for the Power Hitch to operate. Push and hold the toggle switch on the A-frame upward into the "CONNECT" position. Notice the action of the fluid in the reservoir. By activating the initial hydraulic function, the fluid begins to fill the system. Push and hold the toggle switch in the "DISCONNECT" position, the Power Hitch will lower. Refill the reservoir until the fluid is approximately 3/4" from the top of the tank.
3. Position the vehicle such that the Power Hitch is below the push beam and the mounting points on the A-frame are in line with the mounting points on the undercarriage. Pull out the A-FRAME LATCH PIN and rotate the A-FRAME LATCH clockwise until the latch is resting on the DRAW PIN (See diagram on page 16). Move the snowplow in position by activating the Power Hitch connect switch and release.



**WARNING: Always use caution when operating the Power Hitch CONNECT/DISCONNECT switch. Keep your hands and feet away from the operation of the Power Hitch and the main blade. The action of the Power Hitch moves the snowplow in position for proper attachment to the vehicle. Failure to follow this caution may result in serious injury or death.**

The Power Hitch will raise until it hits the push beam and the DRAW LATCH FINGERS will pull the plow into the vehicle. The mounting points on the plow and vehicle are now positively aligned. Rotate the A-frame latch counterclockwise until the latch is in the raised position. *Note: The A-frame latch pin should always lock in place. Do not set the pin past the lock point on the A-frame.* Insert the two HITCH PINS through the mounting holes on the A-frame and secure each with one hair pin cotter. The snowplow is now securely mounted to the vehicle.

4. Return to the interior of the vehicle. With the plow securely in place, you can now execute the remaining functions of the snowplow. The system power on the control station should be in the "ON" position. Next, raise the plow to its maximum height by pushing and holding the "RAISE" rocker switch on the control station. Initiate the driver's side wing by pushing and holding the "LEFT WING EXTEND" rocker switch until the wing pivots forward. Notice the staggered pace the wing extends. The hydraulic fluid is filling the hose and replacing the air in the system.



Push and hold the “LEFT WING RETRACT” rocker switch to return the wing. Continue testing the remaining rocker switch functions. Monitor the fluid level in the reservoir and fill to 3/4" from the top of the tank if needed. Also, look for any hydraulic fluid leaks around the manifold, pump, hydraulic hoses and all cylinders.

- 5. Lastly, check that the vehicle and plow headlights are in proper working condition including the turn signals. If necessary, adjust the plow headlight beams with the plow in the raised position.

Congratulations on a successful assembly and installation! Once all of the blade and electrical functions have been tested your Blizzard Power Plow snowplow is ready for action. Should you need additional support during a plow assembly or undercarriage installation, contact your local authorized Blizzard dealer.



# Power Hitch™ Instruction

Prior to operating your Power Plow snowplow review the Mounting & Dismounting Instructions label at the driver's side rear of the moldboard.



## MOUNTING & DISMOUNTING INSTRUCTIONS

### MOUNTING

1. Position vehicle close to the plow and align mounting points on the undercarriage and A-frame. Verify that the plow kickstand is in the lowered position. Turn vehicle ignition off.
2. Turn power supply switch on the main plow control unit in the vehicle to the "OFF" position.
3. Remove protective weather caps and make electrical connection at the plow and vehicle.
4. Turn the vehicle ignition, and the power supply switch on the control unit, to the "ON" position. Pull the A-frame latch lock pin outward and verify that the A-frame latch lowers over the draw pin.
5. Activate the Power Hitch on the A-frame by pushing and holding the "CONNECT/ DISCONNECT" switch (on the pump cover housing) upward. **CAUTION: Keep fingers away from plow and truck mounting points. Power Hitch will automatically pull the plow into the receiving points on the truck when activated.** Insert both hitch pins through the positively aligned holes on the plow and undercarriage and secure each with a hair pin cotter.
6. With the plow securely mounted, slightly lower the Power Hitch to relieve tension on the A-frame latch, pull the latch lock pin and raise the A-frame latch until it locks into position. Raise the Power Hitch and verify that the draw latch is fully engaged behind the push beam on the vehicle. Rotate the kickstand counterclockwise until it locks into place. The plow is now properly mounted and ready to operate.

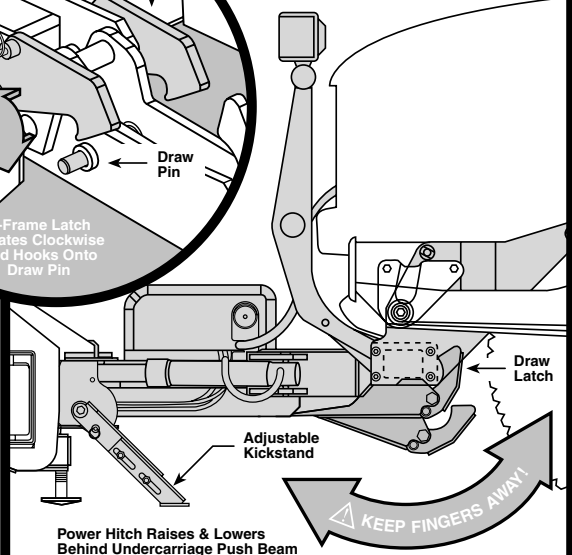
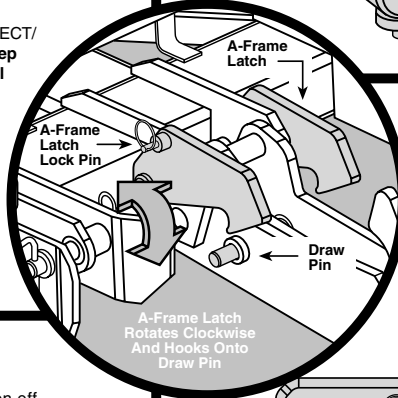
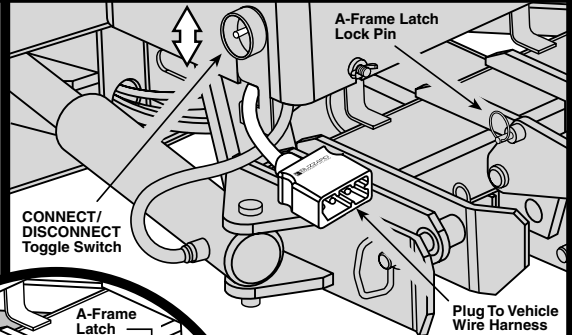

### DISMOUNTING

1. Lower the plow on a flat, level surface to dismount. Turn vehicle ignition off.
2. Pull the kickstand lock pin outward and rotate the kickstand clockwise. Release the pin to lock kickstand in place. Remove both hitch pins from the A-frame and undercarriage.
3. Turn the vehicle ignition and the power supply switch on the control unit to the "ON" position. Activate the Power Hitch by pushing and holding the "CONNECT/DISCONNECT" switch downward. **CAUTION: Keep fingers away from plow and truck mounting points.** Verify that the draw latch is fully disengaged from behind the push beam on the vehicle.
4. Turn power supply switch on the main plow control unit in the vehicle to the "OFF" position.
5. Disconnect electrical cords at the plow and vehicle. Replace protective weather caps.

BLZ 1023

Should the Mounting & Dismounting Instructions label or any of the labels that came with your snowplow become hard to read or wear off, contact your local authorized Blizzard dealer for replacements.

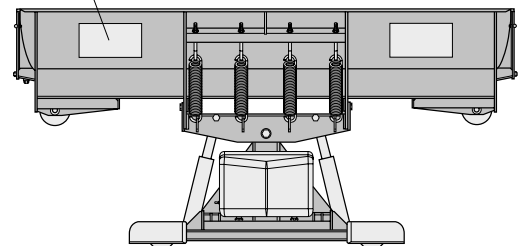







# Plow Specifications

## Moldboard

Length .....8'  
 Thickness .....12 Gauge  
 Height .....31"  
 Reinforcement .....4 Ribs @ 1/4"  
 Cutting Edge .....1/2" x 6" (1080)  
 Finish.....Powder Coat - White

## Wings

Length .....12"  
 Thickness .....11 Gauge  
 Height .....31"  
 Reinforcement .....1 Rib each @ 1/4"  
 Cutting Edge .....1/4" x 10" (T1)  
 Finish.....Powder Coat - White

## Trip Mechanism

Trip Spring Type .....(4) 3/8" Hooked Extension  
 Trip Spring Adjustment .....5/8"-11 x 6-3/8" Spade Bolts

## A-frame

Material .....Rectangular Tube & Channel Type  
 Hitch Pins.....3/4" x 6" Yellow Zinc  
 Finish.....Powder Coat - Black

## Pump

Construction .....Steel Housing w/Clear Plastic Tank  
 Type .....Internal Gear Pump  
 Size.....2.5 cc  
 Motor .....12V Starter  
 Volume Per Minute .....1.6 GPM @ 2000 PSI  
 Weight .....32 lb.  
 Mount.....A-frame Install w/Hex Head Screws  
 Reservoir Capacity .....2 quarts  
 Controls .....Toggle & Rocker Switch

## Manifold

Construction .....Red Anodized Aluminum  
 Hose Ports .....8  
 Cartridge Valves.....9  
 Relief Valve.....5  
 Flow Control Valve .....1  
 Weight .....23.1 lb.  
 Mount.....A-frame Install w/Hex Head Screws  
 Maximum Flow Capacity .....3.0 gpm

## Cylinders

*Angle Cylinders* .....2  
 Stroke .....10"  
 Ram Diameter.....1-3/4"  
 Bore Diameter.....2"  
  
*Lower/Raise Cylinder* .....1  
 Stroke .....4-5/8"  
 Ram Diameter.....1-1/4"  
 Bore Diameter.....3"  
  
*Slide Box Cylinders* .....2  
 Stroke .....13-15/16"  
 Ram Diameter.....1"  
 Bore Diameter.....1-1/2"

## Plow Headlights

Type .....Low Profile w/Turn Signals  
 Measurements .....12" W x 5"H x 5-1/4"D  
 Housing .....Plastic Composite  
 Mount .....Adjustable Ball Type  
 Bulb Type.....High/Low Sealed Beam Halogen, 12V Rectangular  
 Switch Type .....Integrated On/Off Control Station Switch

## Miscellaneous

Plow Weight\* .....Approx. 950 lb.  
 Compact Plow Width .....96" (8'-0")  
 WidePass™ Plow Width .....120" (10'-0")  
 BucketBlade™ Plow Width.....111" (9'-3")  
 Adjustable Plow Shoes.....(2) Heavy-Duty Cast Steel  
 Mount Mechanism.....Hydraulic Power Hitch  
 Standard Control Station .....Rocker Switch  
 Optional Control Station .....Joystick/Rocker Switch or Touch Pad

\*Plow weight does not include vehicle undercarriage.

All specifications are for the Model 810 Blizzard Power Plow snowplow.

Blizzard Corporation reserves the right, under its Continuous Improvement Policy, to change construction or design details and furnish equipment when so altered without reference to illustrations or specifications.

# Torque Specifications

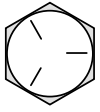

- Grade Identification Marking for J429 - Grade 5 Bolt**
- Material: Medium carbon steel: quenched and tempered
  - Minimum Proof Strength: 85,000 psi
  - Minimum Tensile Strength: 120,000 psi
  - Core Hardness Rockwell (min.): C25, (max.): C34
  - Minimum Yield Strength: 92,000 psi

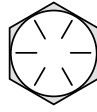

- Grade Identification Marking for J429 - Grade 8 Bolt**
- Material: Medium carbon alloy steel: quenched and tempered
  - Minimum Proof Strength: 120,000 psi
  - Minimum Tensile Strength: 150,000 psi
  - Core Hardness Rockwell (min.): C33, (max.): C39
  - Minimum Yield Strength: 130,000 psi

Nominal Thread Size	SAE J429 - Grade 5			Nominal Thread Size	SAE J429 - Grade 8		
	Clamp Loads (lbs.)	Tightening Torque			Clamp Loads (lbs.)	Tightening Torque	
		"Lubricated"	"Dry"			"Lubricated"	"Dry"
1/4-20	2,000	75 in-lbs	100 in-lbs	1/4-20	2,850	107 in-lbs	143 in-lbs
5/16-18	3,350	157 in-lbs	210 in-lbs	5/16-18	4,700	220 in-lbs	305 in-lbs
3/8-16	4,950	23 ft-lbs	31 ft-lbs	3/8-16	6,950	32.5 ft-lbs	44 ft-lbs
7/16-14	6,800	37 ft-lbs	50 ft-lbs	7/16-14	9,600	53 ft-lbs	70 ft-lbs
1/2-13	9,050	57 ft-lbs	75 ft-lbs	1/2-13	12,800	80 ft-lbs	107 ft-lbs
9/16-12	11,600	82 ft-lbs	109 ft-lbs	9/16-12	16,400	115 ft-lbs	154 ft-lbs
5/8-11	14,500	113 ft-lbs	151 ft-lbs	5/8-11	20,300	159 ft-lbs	21 ft-lbs
3/4-10	21,300	200 ft-lbs	266 ft-lbs	3/4-10	30,100	282 ft-lbs	376 ft-lbs
7/8-9	29,435	321 ft-lbs	430 ft-lbs	7/8-9	41,550	454 ft-lbs	606 ft-lbs
1-8	38,600	482.5 ft-lbs	640 ft-lbs	1-8	54,540	680 ft-lbs	900 ft-lbs



- Grade Identification Marking for Metric - Grade 8.8 Bolt**
- Material: Medium carbon steel: quenched and tempered
  - Minimum Proof Strength: 580 MPa
  - Minimum Tensile Strength: 800 MPa
  - Core Hardness Rockwell (min.): C22, (max.): C32
  - Minimum Yield Strength: 640 MPa

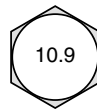

- Grade Identification Marking for Metric - Grade 10.9 Bolt**
- Material: Low carbon alloy steel: quenched and tempered
  - Minimum Proof Strength: 830 MPa
  - Minimum Tensile Strength: 1040 MPa
  - Core Hardness Rockwell (min.): C32, (max.): C39
  - Minimum Yield Strength: 940 MPa

Diameter (millimeters)	Metric Class 8.8			Diameter (millimeters)	Metric Class 10.9		
	Clamp Loads (Newton)	Tightening Torque			Clamp Loads (Newton)	Tightening Torque	
		"Lubricated"	"Dry"			"Lubricated"	"Dry"
5	6177	4.63 N-m	6.18 N-m	5	8840	6.63 N-m	8.84 N-m
6	8743	7.87 N-m	10.5 N-m	6	12512	11.3 N-m	15.0 N-m
7	12570	13.2 N-m	17.6 N-m	7	17990	18.9 N-m	25.2 N-m
8	15921	19.1 N-m	25.5 N-m	8	22784	27.3 N-m	36.5 N-m
10	25230	37.8 N-m	50.5 N-m	10	36105	54.1 N-m	72.2 N-m
12	36670	66.0 N-m	88.0 N-m	12	52475	94.5 N-m	125 N-m
14	50025	105 N-m	140 N-m	14	71587	150 N-m	200 N-m
16	70650	170 N-m	226 N-m	16	97732	235 N-m	313 N-m
18	86400	233 N-m	311 N-m	18	119520	323 N-m	430 N-m
20	110250	330 N-m	441 N-m	20	152513	458 N-m	610 N-m

37° JIC Flare Torque Values			
Turns	Size	ft-lbs min./max.	Assembly Steps w/Visual Check
N/A	-02	6 - 7	1. Make sure the tubing and threads are clean.
N/A	-03	8 - 9	2. Lubricate the threads with 10W hydraulic oil.
2	-04	11 - 12	3. Hand tighten the nut/sleeve to approx. 30 in-lbs.
2	-05	14 - 15	4. Make alignment marks on the nut and fitting.
1-1/2	-06	18 - 20	5. Proceed to tighten to turns or ft-lb values.
1-1/2	-08	36 - 39	6. When fully tightened make a 2nd set of alignment marks at the fully tightened position.
1-1/2	-10	57 - 63	
1-1/4	-12	79 - 88	
1	-14	94 - 103	
1	-16	108 - 113	<b>Note: Torque values specified are for threads lubricated with 10W hydraulic oil.</b>
1	-20	127 - 133	
1	-24	158 - 167	Sizes -02 through -08 are less tolerant to over-torque abuse. This will reduce the clamping force resulting in loss of seal and reduction in flow.
1	-32	245 - 258	

O-Ring Boss Torque Values		
Size	ft-lbs min./max.	O-Ring Boss Assembly
-02	6 - 7	1. Verify the port, O-ring, sealing surfaces, and threads are clean and free of damage.
-03	8 - 10	2. Lubricate the threads and the O-ring with 10W hydraulic oil.
-04	13 - 15	3. For an adjustable O.R.B., completely back-off the lock nut and the washer.
-05	17 - 21	4. Hand tighten the fitting until it contacts the port spotface. Point the elbow or tee in the desired direction and hold.
-06	22 - 25	5. Proceed to tighten to the proper specified torque value.
-08	40 - 43	
-10	43 - 57	
-12	68 - 75	
-14	90 - 99	
-16	112 - 123	<b>Note: Torque values specified are for threads lubricated with 10W hydraulic oil.</b>
-20	146 - 200	
-24	154 - 215	
-32	218 - 290	

**Disclaimer:** All torque values included in the charts above are advisory only, and their use by anyone is entirely voluntary. Reliance on the contents for any purpose by anyone is the sole risk of that person and Blizzard Corporation is not responsible for any loss, claim or damages arising therefrom. Blizzard Corporation has made an effort to present the above contents accurately, but we do not guarantee its completeness or validity. This information is subject to change at any time, without notice. Blizzard Corporation makes no representations or warranties, express or implied, in connection with the information.

## MODEL 810 PARTS LIST

Ref. No.	Part Number	Qty.	Part Description
<b>Moldboard &amp; Wing Assembly Parts</b>			
1	52074	1	Moldboard Weldment
2	61086	1	Label, WARNING! (BLZ 1005)
3	61082	1	Decal, Center Moldboard (BLZ 1000)
4	61180	1	Label, Power Hitch™ Mounting & Dismounting Instructions (BLZ 1023)
5	61292	1	Cutting Edge (1080), Moldboard
6	61196	7	Bolt, Carriage, 1/2"-13 x 1-1/2" Grade 8 P
7	61365	13	Nut, Flanged Lock, 1/2"-13 Z
8	51042	1	Wing Weldment, Driver's Side
9	61083	1	Decal, Wing, Driver's Side (BLZ 1002)
10	51048	1	Cutting Edge Weldment (T1), Wing, Driver's Side
11	50057	1	Slide Box Weldment, Driver's Side
<b>12A</b>	<b>61220</b>	<b>2</b>	<b>Plow Shoe Assembly, Heavy-Duty Cast Iron (8-3/8" Shaft): (1) - 12, 14, (18) - 13</b>
12	61102	2	Spacer, 1-1/8" I.D., 1-5/8" O.D. x 1-1/2" YZ
13	61101	36	Washer, Flat, 1", 1-1/016" I.D., 1-3/4" O.D. YZ
14	61103	2	Pin, Linch, 1/2" x 1-3/4" YZ
15	63063	1	Label, Serial Number, Sequentially Numbered (BLZ 1049)
16	61383	4	Screw, Hex Head Cap, 5/16"-18 x 2-1/4" Grade 8 YZ
17	11871	4	Pin, Slide Box Stop, 1" DIA. x 4-3/4" (with 3/8" DIA. hole)
18	61384	4	Nut, Top Lock, 5/16"-18 Grade C Z
<b>19A</b>	<b>61049</b>	<b>2</b>	<b>Plow Guide Assembly: (2) - 19 &amp; 20</b>
19	61051	4	Screw, Hex Head Cap, 5/16"-18 x 1" Grade 5 Z
20	61052	4	Nut, Nylon Insert Lock, 5/16"-18 Z
21	51043	1	Wing Weldment, Passenger's Side
22	61084	1	Decal, Wing, Passenger's Side (BLZ 1001)
23	51047	1	Cutting Edge Weldment (T1), Wing, Passenger's Side
24	61418	2	Bolt, Carriage, 1/2"-13 x 3-1/2" Grade 8 P
25	61419	2	Bolt, Carriage, 1/2"-13 x 4-1/2" Grade 8 P
26	61361	2	Bolt, Carriage, 1/2"-13 x 5-1/2" Grade 8 P
27	50058	1	Slide Box Weldment, Passenger's Side
28	61416	2	Bolt, Spade, 5/8"-11 x 7-3/8" Grade 8 Z
29	61398	2	Spring, Extension, 13" O.A.L. x 2" O.D. x 5/16"
30	61385	2	Pin, Clevis, 5/8" DIA. x 3" YZ
31	61028	2	Pin, Spring, 1/4" DIA. x 1-1/4"
32	51009	2	Pin, Wing/Slide Box Pivot, 3/4" DIA. x 9"
33	61425	2	Plug, 2-51/64" O.D., 2-9/32" I.D. x 1/2" Black Polyethylene
34	14622	2	Hydraulic Cylinder, Slide Box Extend/Retract
35	61063	2	Nut, Top Lock, 5/8"-11 Grade C Z
36	60007	7	Hydraulic Adapter, 9/16"-18 x 9/16"-18 Male O.R.B. Connector
37	60224	2	Hydraulic Hose (Ports #8 & #9), 3/8" x 36" - Slide Box Extend
38	60003	4	Hydraulic Adapter, 7/16"-20 x 9/16"-18 Male O.R.B. Connector
39	60019	2	Hydraulic Hose (Ports #7 & #10), 1/4" x 36" - Slide Box Retract
40	61198	2	Cap, 5/8" I.D., 3/4" O.D. x 1", Black Vinyl
41	11989	2	Pin, Hydraulic Cylinder Base End, 5/8" DIA. x 11-1/2" (with 1/4" DIA. hole) - Slide Box Extend/Retract
42	61030	2	Pin, Hair Cotter, 1/8" DIA. x 2-5/8" Z
43	61099	4	Spring, Extension, 15-1/4" O.A.L. x 2-3/8" O.D. x 3/8"
44	61187	4	Bolt, Spade, 5/8"-11 x 6-3/8" Grade 8 Z
45	61064	4	Washer, SAE Mil Carb High-Strength, 5/8", 1-5/16" O.D., 21/32" I.D. YZ
46	61188	4	Nut, Nylon Insert Lock, 5/8"-11 Type NE
<b>Pivot Beam &amp; A-frame Assembly Parts</b>			
47	41041	1	Pivot Beam Weldment
48	61357	8	Pin, Cotter, 1/4" x 1-1/2" Z
<b>49A</b>	<b>41039</b>	<b>1</b>	<b>Kickstand Assembly: (1) - 49 &amp; 50, 54-56, (2) - 51 &amp; 52, (3) - 53</b>
49	41047	1	Kickstand Foot Weldment
50	41038	1	Kickstand Leg Weldment
51	61057	2	Screw, Hex Head Cap, 1/2"-13 x 1-1/4" Grade 8 YZ
52	61026	2	Washer, SAE Mil-Carb High-Strength, 1/2", 1-1/16" O.D., 17/32" I.D. YZ
53	61020	3	Nut, Top Lock, 1/2"-13 Grade C Z
54	61152	1	Screw, Hex Head Cap, 1/2"-13 x 4-1/2" Grade 8 YZ
55	61293	1	Spring, Compression, 2" O.A.L. x 1.101" O.D., 0.207" Wire Diameter
56	41037	1	Bushing, Stepped, 1.13" O.D., 0.53" I.D. x 3/8" Stainless Steel
57	50069	2	Pin, Clevis, 3/4" DIA. x 3" YZ
58	41051	4	Pin, Clevis, 3/4" DIA. x 5" YZ
59	61330	1	Screw, Hex Head Cap, 1"-8 x 9" (with 7-3/4" Shank) Grade 8 P
60	61008	1	Nut, Top Lock, 1"-8 Grade C Z
61	61217	4	Grommet, 1-1/2" I.D., 2-1/8" O.D. Black Rubber, 60 Durometer
62	60029	2	Hydraulic Cylinder, Plow Angle
63	60091	2	Hydraulic Hose (Ports #1 & #2), 3/8" x 24" - Plow Angle

*Note: The reference numbers listed identify parts shown in the illustration on pages 26-28. These numbers are specific to these illustrations only and do not correspond with other diagrams in the manual. Always review the part number given for proper component identification.*



## MODEL 810 PARTS LIST

Ref. No.	Part Number	Qty.	Part Description
<b>Pivot Beam &amp; A-frame Assembly Parts (Continued)</b>			
64	60005	3	Hydraulic Adapter, 9/16"-18 x 9/16"-18 90° Adjustable Elbow O.R.B.
65	60255	1	Hydraulic Cylinder, Plow Raise/Lower
66	40124	1	Pin, Clevis, 3/4" DIA. x 6" YZ
67	60273	1	Hydraulic Hose (Port #3), Straight/45°, 3/8" x 17" - Plow Raise/Lower, Extend (Base End)
68	60272	1	Hydraulic Adapter, 9/16"-18 x 9/16"-18 45° Adjustable Elbow O.R.B.
69	60274	1	Hydraulic Hose (Port #4), Straight/45°, 3/8" x 15" - Plow Raise/Lower, Retract (Rod End)
70	61358	3	Nut, Flanged Wing, 3/8"-16
71	61012	2	Screw, Hex Head Cap, 3/8"-16 x 3/4" Grade 8 YZ
72	61016	3	Washer, SAE Mil-Carb High-Strength, 3/8", 13/16" O.D., 13/32" I.D., YZ
73	61014	1	Nut, Jam Nylon Insert Lock, 3/8"-16 Z, Type NTE
74	61359	1	Stud, Threaded, 3/8"-16 x 1-3/4"
75	40004	1	Hinge Weldment, Pump Mount
76	61218	1	Screw, Hex Head Cap, 3/8"-16 x 2" Grade 8 YZ
77	61034	1	Nut, Top Lock, 3/8"-16 Grade C Z
78	62038	1	Switch, Toggle, DPDT, (On)-Off-(On), 16 Amps, 115V AC - Draw Latch Connect/Disconnect
<b>79A</b>	<b>40106</b>	<b>1</b>	<b>A-frame Assembly: (1) - 75-77, 79, 82-84, 88, (2) - 87, (4) - 85 &amp; 86</b>
79	40090	1	A-frame Weldment
80	61426	2	Pin, Hitch, 3/4" x 6" YZ
81	61105	2	Pin, Hair Cotter, 9/64" DIA. x 2-11/16" Z
82	61309	3	Ring, Standard Split, Stainless Steel
83	61000	3	Spring, Compression, 0.94" O.A.F.L. x 0.36" O.D., 0.029" Wire Diameter, Stainless Steel
84	40079	3	Pin, A-frame Latch, 3/8" DIA. x 1-3/4", Stainless Steel
85	61312	4	Screw, Hex Head Cap, 5/16"-18 x 3/4" Grade 8 YZ
86	61011	6	Washer, Split Lock, 5/16" YZ High-Alloy
87	40088	2	Bushing, A-frame Pivot, Replaceable
88	61295	1	Label, Power Hitch Connect/Disconnect Switch (BLZ 1037)
<b>Draw Latch Assembly Parts</b>			
<b>89A</b>	<b>40109</b>	<b>1</b>	<b>Draw Latch Assembly: (1) - 48, 89-92, 94-96, 98-102, (2) - 93 &amp; 97</b>
89	40080	1	Outer Draw Latch Plate Weldment, Driver's Side
90	40110	1	Pin, Draw, 1" DIA. x 6-1/2" (with 13/64" DIA. Cotter Pin Hole) YZ
91	61363	1	Pin, Cotter, 3/16" DIA. x 2-1/2" Z
92	61004	1	Screw, Hex Head Cap, 3/4"-10 x 4-1/2" Grade 8 YZ
93	40074	2	Inner Draw Latch Plate
94	40070	1	Pin, Draw Latch Mount (To A-frame), 1" x 4-21/32" YZ
95	40114	1	Draw Latch Arm Weldment
96	40123	1	Draw Latch Finger Weldment
97	40042	2	Pin, 3/4" x 2-1/2", Draw Latch Arm Pivot Pin/Hydraulic Cylinder Rod End, Plow Raise/Lower
98	40093	1	Bushing, 1-1/4" O.D., 1-1/16" I.D. x 1-1/2" YZ
99	40081	1	Outer Draw Latch Plate Weldment, Passenger's Side
100	50071	1	Pin, Clevis, 3/4" DIA. x 3-41/64" YZ
101	40116	1	Spacer, 1" O.D., 25/32" I.D. x 5/8" YZ
102	61006	1	Nut, Top Lock, 3/4"-10 Grade C Z
<b>Hydraulic Pump &amp; Manifold Assembly Parts</b>			
<b>103A</b>	<b>60101</b>	<b>1</b>	<b>Hydraulic Pump Assembly (Fenner Fluid Power): (1) - 103, 104, 106 &amp; 107</b>
103	60047	1	Power Unit (Motor), Hydraulic Pump
104	60044	1	Hex Cap, Relief Valve, Hydraulic Pump
105	61307	1	Washer, Internal/External Tooth Lock, 3/8"
106	60046	1	Reservoir Cap, Hydraulic Pump
107	60045	1	Reservoir, Hydraulic Pump
108	40119	1	Cover, Hydraulic Pump & Manifold, 1/4" Polyethylene
109	63100	1	Label, Sequence Valve & Hydraulic Hose Identification Guide (BLZ 1055)
110	60038	2	O-ring, 3/32" C.S.W., 9/16" I.D., 3/4" O.D. Neoprene, 70 Durometer
111	82047	1	Bracket, Diode Board Mount
112	61214	2	Screw, Hex Head Cap, 3/8"-16 x 1-1/4" Grade 8 YZ
113	61222	2	Washer, Split Lock, 3/8" High-Alloy YZ
114	61010	2	Screw, Hex Head Cap, 5/16"-18 x 3-3/4" Grade 8 YZ
<b>115A</b>	<b>60264</b>	<b>1</b>	<b>Manifold Assembly: (1)-64, 115, 119, 122, 124A, 129-133, (2)-38, 117, 120, 126-128, (3)-116, (4)-36, 118, 121, (5)-123, (9)-125</b>
115	60266	1	Manifold Block (with Cross Port Relief), Red Anodized Aluminum
116	60050	3	Plug, Hollow Hex, -6 SAE (61010007)
117	60009	2	Hydraulic Adapter, 7/16"-20 90° Swivel Elbow
118	60006	4	Hydraulic Adapter, 9/16"-18 90° Swivel Elbow
119	60072	1	Hydraulic Adapter, 9/16"-18 x 9/16"-18 Male Extra Long Elbow
120	60228	2	Piston Assembly (34952123)
121	60225	4	Valve, Check, 50 PSI (86020028)
122	60173	1	Coupling, Test Port, 7/16"-20 O.R.B. (61600095)
123	60166	5	Valve, Spool, Three-Way, Two Position (86020195 w/o screen)

## MODEL 810 PARTS LIST

Ref. No.	Part Number	Qty.	Part Description
<b>Hydraulic Pump &amp; Manifold Parts (Continued)</b>			
<b>124A</b>	<b>62147</b>	<b>1</b>	<b>Coil Harness Assembly: (1) - 130, 62045, 62116, 62118, (8) - 124, (9) - 62096, 62097</b>
124	62114	8	Coil, PDL 10V DC
125	60052	9	Nut, Hex Jam, 1/2"-20 YZ
N/A	62045	1	Connector, Electric, Male, Plastic
N/A	62096	19	Seal, Cable, Silicone, Orange (18 AWG)
N/A	62116	1	Cavity Plug, Silicone, White (18-16 AWG)
N/A	62097	9	Terminal, Male (18-16 AWG)
N/A	62118	1	Terminal, End Ring, 3/8" I.D. Copper, 6 Gauge
126	60278	2	Valve, Relief, 1700 PSI (85020411 tamper proof)
127	60279	2	Valve, Relief, 1500 PSI (85020410 tamper proof)
128	60167	2	Valve, Spool, Four-Way, Two Position C.C. (86020197 w/o screen)
129	60168	1	Valve, Relief, 3000 PSI (85020340)
130	62115	1	Coil, DDL 10V DC
131	60170	1	Valve, Spool, Three-Way, Two Position (85002279 w/o screen)
132	60169	1	Valve, Flow Control (85002054)
133	60165	1	Valve, Two-Way N.C. (86020190)
<b>Snowplow Wire Harness Assembly Parts</b>			
<b>134A</b>	<b>62039</b>	<b>1</b>	<b>Wire Harness Assembly, Plow : (1) - 134, 135, 62006, 62046, (10) - 62096</b>
134	62057	1	Wire Harness, Plow
135	62001	1	Weather Cap, Rubber, Plow Wire Harness
N/A	62046	1	Connector, Electric, Female, Plastic
<b>N/A</b>	<b>62006</b>	<b>1</b>	<b>Diode Board Assembly: (1) - 62007, 62090, 62092, 62094, 62095, (5) - 62091, 62093</b>
N/A	62007	1	Cover, Black, Diode Board
N/A	62090	1	Connector Body w/Gasket, Diode Board
N/A	62091	5	Seal, Cable, Silicone, Green (16 AWG)
N/A	62092	1	Plug, Cavity, Silicone, Green (16 AWG)
N/A	62093	15	Terminal, Female (18-16 AWG)
N/A	62094	1	Circuit Board
N/A	62095	1	Secondary Lock, Six-Way
<b>Vehicle Wire Harness Assembly Parts</b>			
<b>136A</b>	<b>62112</b>	<b>1</b>	<b>Wire Harness Assembly, Vehicle - Relay Version: (1) - 136, 137, 62124, 62113, 62125, 62008, 62009, 62056 (3) - 61031, 62016, (4) - 62072</b>
136	62111	1	Wire Harness, Vehicle - Relay Version
137	62000	1	Weather Cap, Rubber, Vehicle Wire Harness
N/A	62124	1	Fuse, 1/4" DIA. x 1-1/4" BUSS AGC 15A, 32V
N/A	62113	1	Main Lighting Harness - Relay Version
N/A	62125	1	Headlight Relay, 3PDT, 30A, 12V
N/A	61031	3	Screw, Hex Washer Self-Drilling, 12-14 x 3/4"
N/A	62042	1	Power Contactor (Solenoid), 12V Continuous, High Performance DC Plastic
N/A	61228	4	Nut, Hex Jam, 5/16"-24 Z
N/A	61229	4	Nut, Hex Full, #10 -32 Z
N/A	61230	2	Washer, Split Lock, #10 Z Medium
N/A	62056	1	Ground Wire, Power Contactor, 24"
N/A	62072	4	Terminal, End Ring, 3/8" I.D. Copper, 4 Gauge
N/A	62008	1	Fuse Clip, Mini
N/A	62009	1	Fuse Clip, Auto Blade
N/A	62016	3	Connector, Splice Lock (18-14 AWG)
<b>138A</b>	<b>61106</b>	<b>2</b>	<b>Headlight Assembly, Plow (Specify Driver's or Passenger's Side): (1) - 138/139, 140-143, 62061</b>
138	61107	1	Headlight, Plow, Driver's Side
139	61108	1	Headlight, Plow, Passenger's Side
140	62032	2	Wire Harness (with 5-pin plug), Plow Headlight
N/A	62061	2	Bulb, Sealed Beam Halogen, Glass, Plow Headlight (H6545/H4666)
N/A	62062	1	Corrosion Preventive Compound (2 fl.oz.)
141	61231	2	Adapter, Ball Stud Mount, Headlight
142	61112	2	Washer, External Tooth Lock, 7/16" YZ
143	61111	2	Nut, Hex, 7/16"-14 Grade 8 YZ
144	61427	2	Cap, 2-1/4" I.D., 2-25/64" O.D. x 1/2", Black Vinyl
145	39032	1	Light Tower
<b>146A</b>	<b>62128</b>	<b>1</b>	<b>Rocker Switch Control Station Assembly - Relay Version: (1) - 146-150, 152, 153, 155, 156, (3) - 151, (4) - 154, 61036</b>
146	61125	1	Housing, Rocker Switch Control Station, 1/8" ABS Plastic
147	62065	1	Switch, Rocker, SPST, Off-None-On, Black/Red 15A, 250V AC (Power - Plow Lights)
148	61126	1	Housing Plate, Rocker Switch Control Station, 1/8" ABS Plastic
149	61127	1	Strap (61" Velcro with 2" Metal D-Ring), Black
150	62130	1	Connector, Electrical (12-pin & 2-pin Plugs)
151	62066	3	Switch, Rocker, DPDT, (On)-Off-(On), White 10A, 250V AC (Wing Extend & Retract - Driver's Side & Passenger's Side, Plow Angle)
152	62129	1	Switch, Rocker, SPDT, On-Off-On, Black 10A, 250V AC (System Power On - System Power Off - Hitch System On)

## MODEL 810 PARTS LIST

Ref. No.	Part Number	Qty.	Part Description
<b>Vehicle Wire Harness Assembly Parts (Continued)</b>			
153	62067	1	Switch, Rocker, DPDT, (On)-Off-On, White 10A, 250V AC (Plow Raise & Lower)
154	61035	4	Screw, Machine, 10-24 x 1/2" Z
N/A	61036	4	U-Clip, 10-24
155	63098	1	Label, Plow Lights/Power Switch ON/OFF (BLZ 1053)
156	61090	1	Label, Rocker Switch Control Station (BLZ 1010)
157	30042	1	Undercarriage Weldment, 1999-Current, Chevrolet/GMC 2500 Series
158	61085	1	Decal, Undercarriage Push Beam, 2-1/4" x 13-7/8" (BLZ 1003)
<b>Miscellaneous Assembly Parts</b>			
N/A	61352	1	Kit, Hardware, Snowplow Assembly Parts: (1) - 72-74, 105, (2) - 57, 71, (3) - 70, (4) - 44-46, 58, (6) - 48
N/A	60275	1	Kit, Hydraulic Adapter: (1) - 68, 119, (2) - 117, (3) - 64, (4) - 38 & 118, (7) - 36
N/A	60280	1	Kit, Hydraulic Hose: (1) - 67, 69, (2) - 37, 39, 63
N/A	61430	1	Kit, Hardware, Moldboard Cutting Edge: (7) - 6 & 7
N/A	52067	1	Kit, Cutting Edge, Moldboard w/Hardware: (1) - 5 & 61430
N/A	61431	1	Kit, Hardware, Wing Cutting Edge: (1) - 24-26, (3) - 7
N/A	51104	1	Kit, Cutting Edges, Wing w/Hardware: (1) - 8, 21, (2) - 61431
N/A	61321	1	Kit, Moldboard & Wing Cutting Edges w/Hardware: (1) - 52067 & 51104

# Snowplow Accessories (continued from page 1)



**Blizzard Snowplow Rapid Action Hydraulic Oil**  
**P/N 63070 (Quart)**  
**P/N 63071 (12 Quarts/Case)**  
**P/N 63072 (Gallon)**  
**P/N 63069 (4 Gallons/Case)**

Blizzard hydraulic oil is specially formulated for use in Blizzard snowplows. This zinc-free product can

significantly enhance the operation and performance of the hydraulic system in the most inclement weather conditions. Blizzard hydraulic oil maintains its viscosity to temperatures as low as -60°F. Blizzard oil is available by the quart, gallon or case.



**Blizzard Snowplow Touch-Up Paint**  
**P/N 61219 (Gloss White)**  
**P/N 63073 (Gloss Black)**

Putting your snowplow away for the winter? Have a deep scratch to cover? Clean up your blade and plow parts with our gloss spray paints. Blizzard snowplow touch-up paint provides an excellent finish to help keep your snowplow looking its best. Paint provided in 12 oz. spray cans.



**Heavy-Duty 3/8" Wing Cutting Edges with Hardware**  
**P/N 61288**

Beef-up your Blizzard Power Plow snowplow with our 3/8" thick wing cutting edges. Made of T1 material, these edges are built to withstand heavy plow use on the roughest road surfaces. These durable wing

edges also provide added material for protection against sidewalk curb wear. Mounting hardware included.

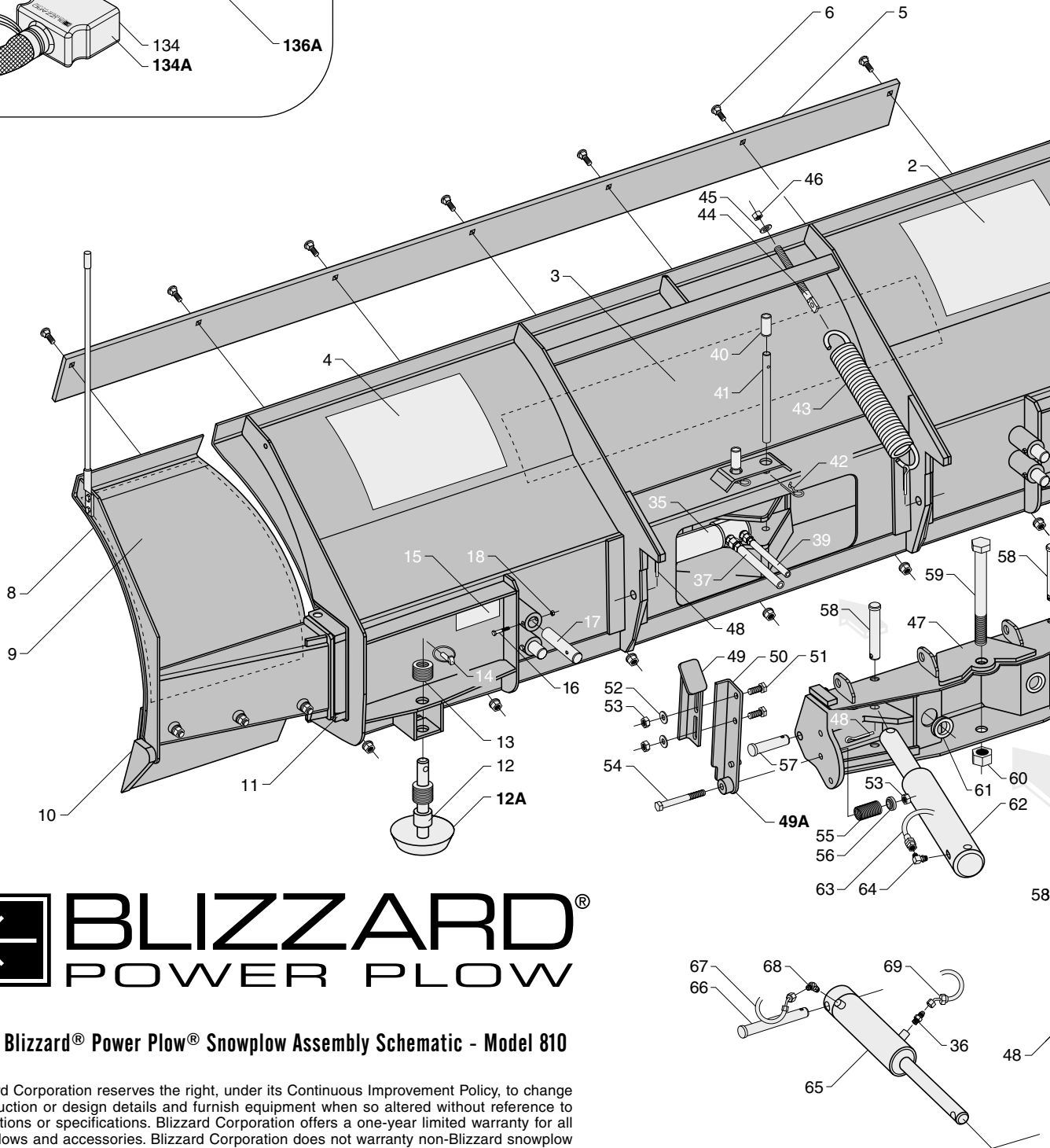
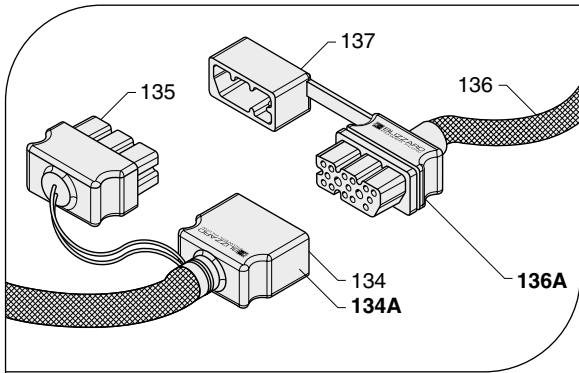

# **BLIZZARD**<sup>®</sup> POWER PLOW

## 2003 Blizzard<sup>®</sup> Power Plow<sup>®</sup> Snowplow Assembly Schematic - Model 810

Blizzard Corporation reserves the right, under its Continuous Improvement Policy, to change construction or design details and furnish equipment when so altered without reference to illustrations or specifications. Blizzard Corporation offers a one-year limited warranty for all snowplows and accessories. Blizzard Corporation does not warranty non-Blizzard snowplow service parts or accessories or damage resulting from the use of these unauthorized items.

The Blizzard Power Plow is protected by U.S. Patents 5,638,618; 5,899,007; 6,178,669; 6,276,076 and 6,393,737. Other patents pending.

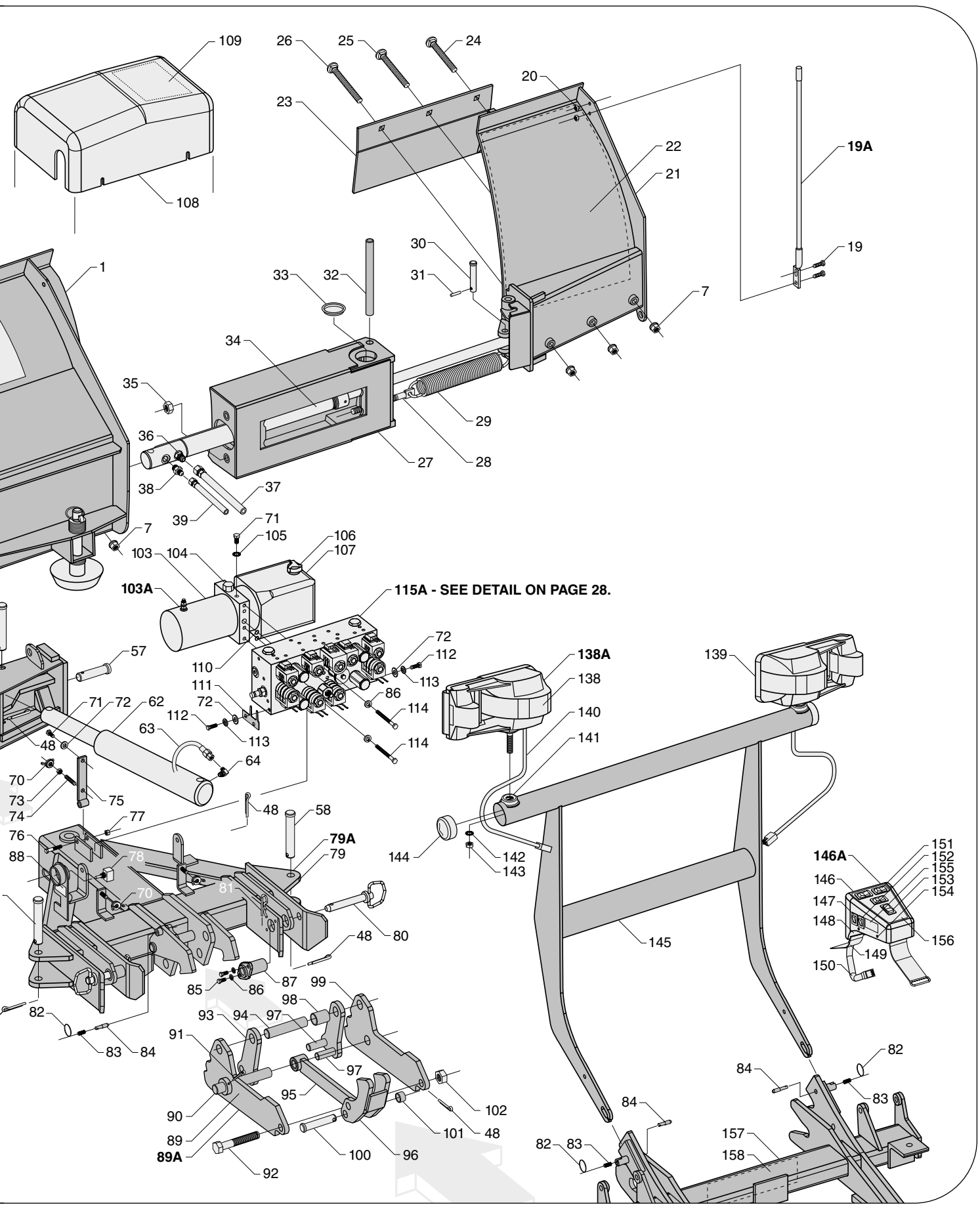

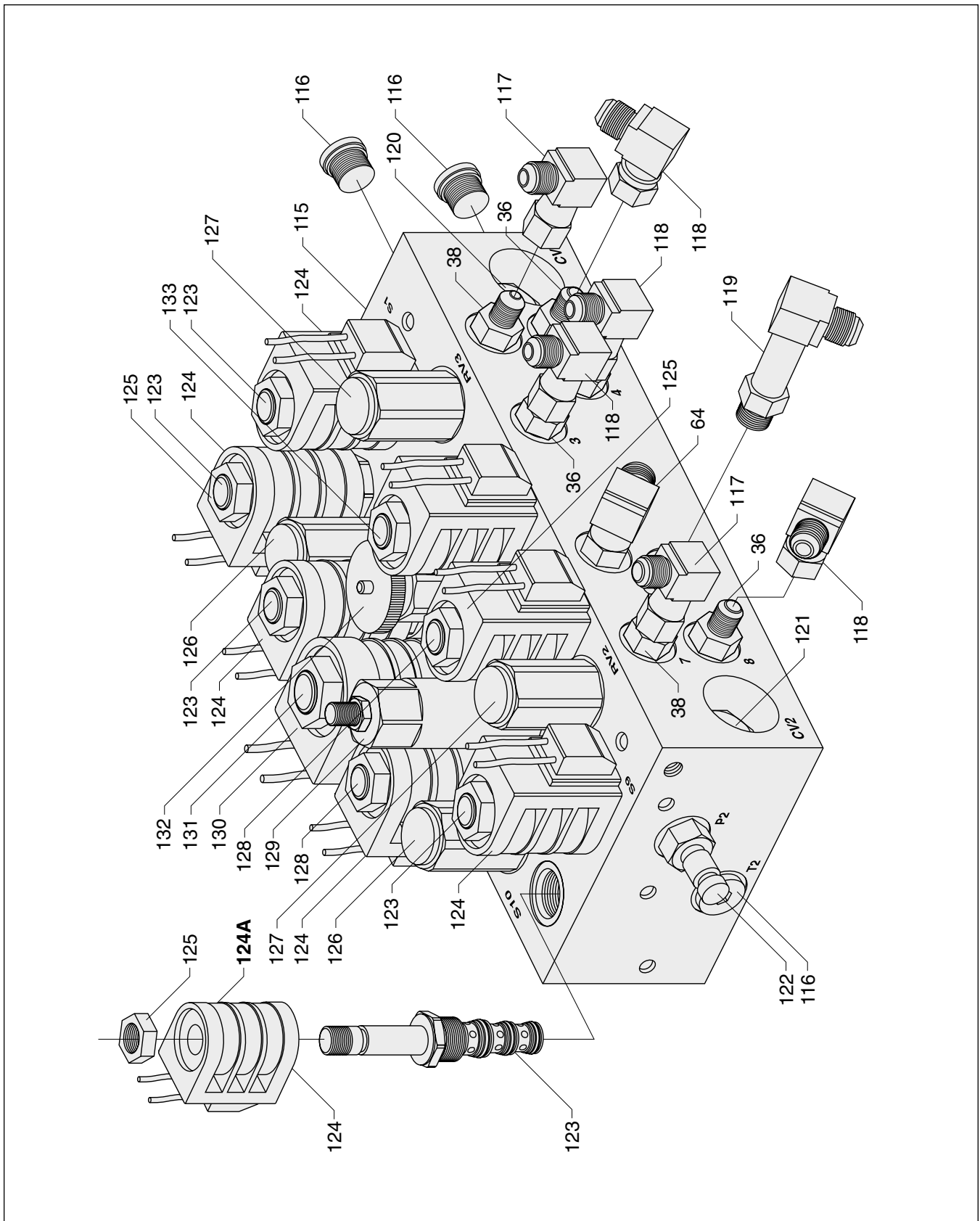

CONNECTS TO M5  
SEE SCHEMATIC ON PAGE 31.

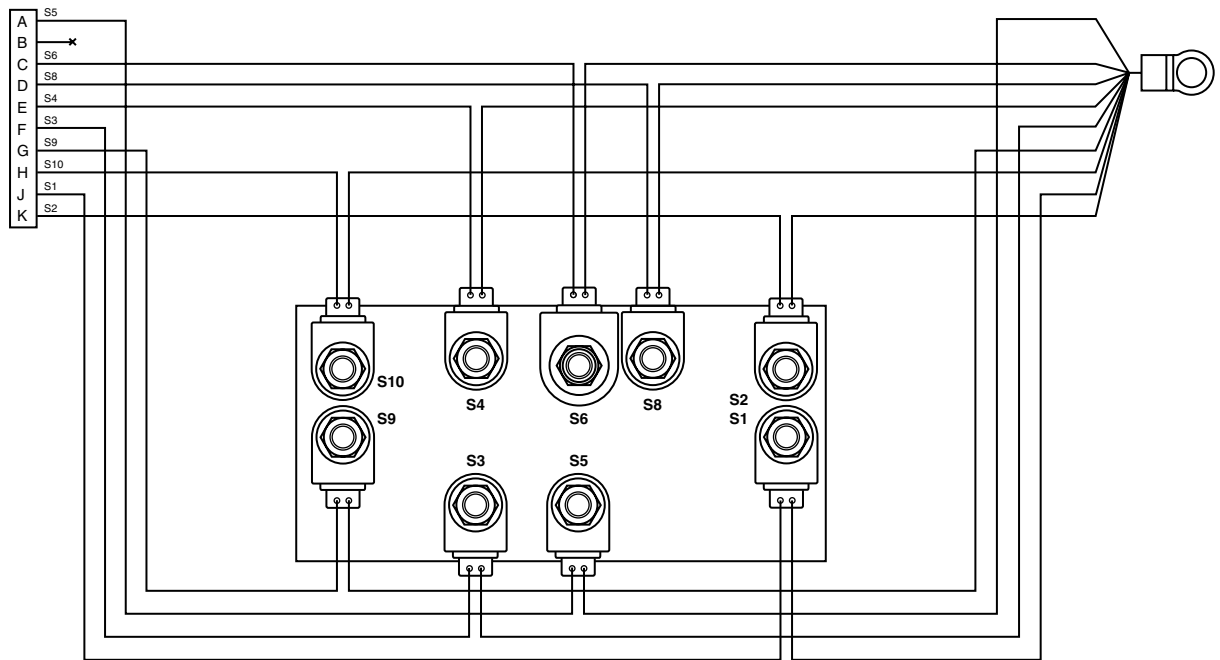

**MODEL 810 COIL HARNESS WIRE SCHEMATIC (2003)**

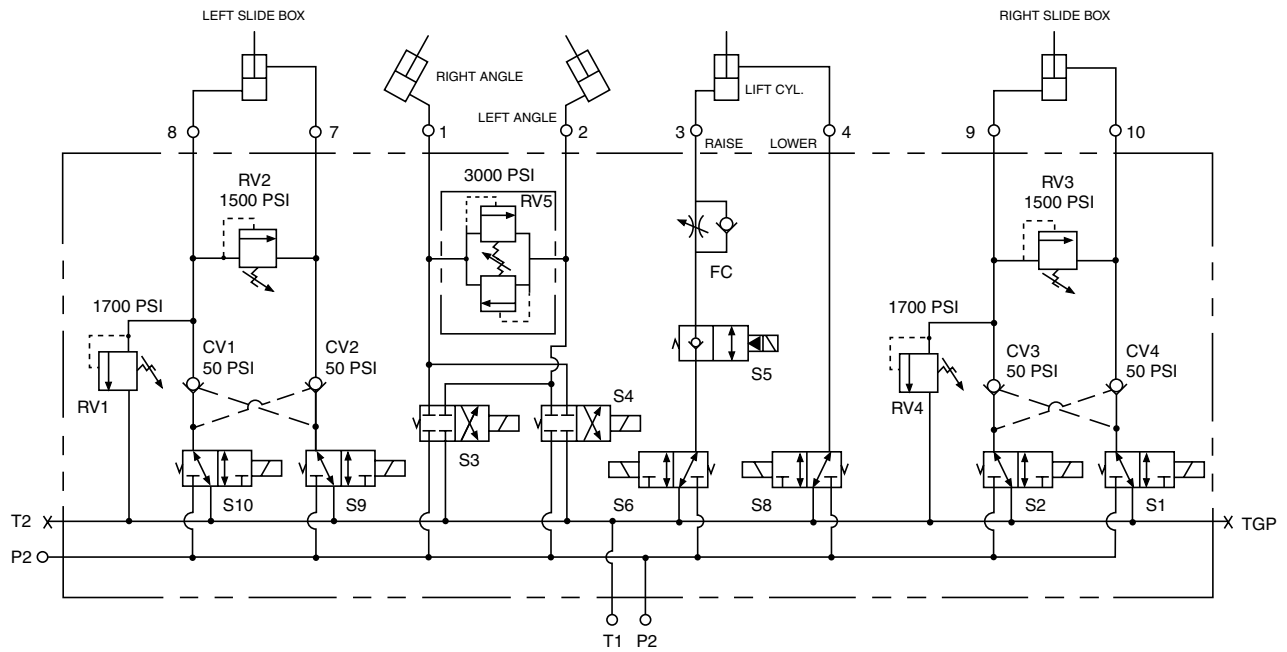

**MODEL 810 HYDRAULIC MANIFOLD SCHEMATIC (2003)**

PIN NO.	COLOR	FUNCTION	AWG
1	BLACK	GROUND	4
2	N/A	N/A	N/A
3	RED	12VDC (+)	4
4	RED/WHITE	RIGHT BOX EXTEND	18
5	RED/BLACK	RIGHT BOX RETRACT	18
6	BLUE/WHITE	LEFT BOX EXTEND	18
7	BLUE/BLACK	LEFT BOX RETRACT	18
8	GREEN	RIGHT ANGLE	18
9	WHITE	LIFT	18
10	WHITE/BLACK	FLCAT	18
11	ORANGE	N/A	N/A
12	N/A	N/A	N/A
13	N/A	N/A	N/A
14	N/A	N/A	N/A
15	PINK/BLACK	12VDC (+) FUSED	18
16	N/A	N/A	N/A

BLIZZARD PLUG (VEHICLE) UNIVERSAL 14 + 2 MOLD			
1	BLACK	GROUND	4
2	N/A	N/A	N/A
3	RED	12VDC (+)	4
4	RED/WHITE	RIGHT BOX EXTEND	18
5	RED/BLACK	RIGHT BOX RETRACT	18
6	BLUE/WHITE	LEFT BOX EXTEND	18
7	BLUE/BLACK	LEFT BOX RETRACT	18
8	GREEN	RIGHT ANGLE	18
9	WHITE	LIFT	18
10	WHITE/BLACK	FLCAT	18
11	ORANGE	N/A	N/A
12	N/A	N/A	N/A
13	N/A	N/A	N/A
14	N/A	N/A	N/A
15	PINK/BLACK	12VDC (+) FUSED	18
16	N/A	N/A	N/A

PACKARD GT 280 ELECTRIC CONNECTOR (PLOW)			
PIN NO.	COLOR	FUNCTION	AWG
A	ORANGE/BLACK	(S5) LOWER/FLOAT	18
B	ORANGE/WHITE	(S7) LEFT/FLOAT	18
C	WHITE/BLACK	(S6) LIFT	18
D	ORANGE/RED	(S8) HITCH-LOWER	18
E	GREEN	(S4) ANGLE RIGHT	18
F	BLUE	(S3) ANGLE LEFT	18
G	BLUE/BLACK	(S9) LEFT SLIDE BOX RET.	18
H	BLUE/WHITE	(S10) LEFT SLIDE BOX EXT.	18
J	RED/BLACK	(S1) RIGHT SLIDE BOX RET.	18
K	RED/WHITE	(S2) RIGHT SLIDE BOX EXT.	18

DIODE PACK ASSEMBLY (P/N 62006)			
DIODE PACK COVER, CLEAR - P/N 62007			
CONNECTOR BODY W/GASKET - P/N 62090			
SILICONE RUBBER CABLE SEAL - P/N 62091			
SILICONE RUBBER CAVITY PLUG - P/N 62092			
CIRCUIT BOARD - P/N 62093			
SIX-WAY SECONDARY LOCK - P/N 62095			

NOTE: GREASE FEMALE TERMINALS			
(5) PINK/BLACK	(6) PINK/BLACK	(3) WHITE	(4) ORANGE/RED
(1) BROWN	(2) BROWN	(7) AND (8) NOT USED	

OTTO CONNECTOR AMP TERMINALS			
(18-14 AWG)			
(TWO 18-14 AWG)			

HIGH AMP WIRES COLORS (PIN 1 - BLACK, PIN 2 - RED)			
WIRE (SGT 4 AWG)			
END RING TERMINALS (3/8" I.D.) - P/N 62072			

VEHICLE HARNESS JACKET MATERIAL			
NYLON BRAID-RED WITH BLACK & WHITE STRIPE			
P/N 62057			

PACKARD GT 280 ELECTRIC CONNECTOR (PLOW)			
PIN NO.	COLOR	FUNCTION	AWG
A	ORANGE/BLACK	(S5) LOWER/FLOAT	18
B	ORANGE/WHITE	(S7) LEFT/FLOAT	18
C	WHITE/BLACK	(S6) LIFT	18
D	ORANGE/RED	(S8) HITCH-LOWER	18
E	GREEN	(S4) ANGLE RIGHT	18
F	BLUE	(S3) ANGLE LEFT	18
G	BLUE/BLACK	(S9) LEFT SLIDE BOX RET.	18
H	BLUE/WHITE	(S10) LEFT SLIDE BOX EXT.	18
J	RED/BLACK	(S1) RIGHT SLIDE BOX RET.	18
K	RED/WHITE	(S2) RIGHT SLIDE BOX EXT.	18

PLASTIC ELECTRIC CONNECTOR, FEMALE - P/N 62046			
SILICONE RUBBER CABLE SEAL - P/N 62096			
FEMALE TERMINAL (18-16 AWG) - P/N 62093			

NOT DRAWN TO SCALE  
UNLESS OTHERWISE SPECIFIED  
ALL DIMENSIONS IN INCHES

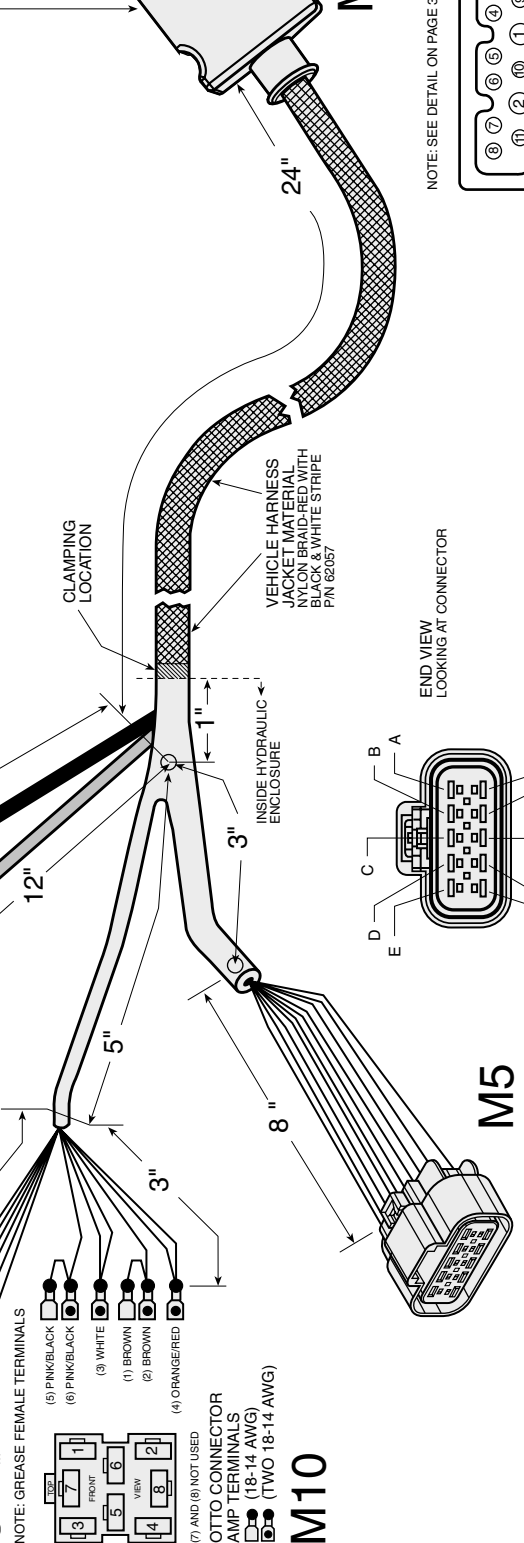

BLIZZARD PLUG (VEHICLE) UNIVERSAL 14 + 2 MOLD			
1	BLACK	GROUND	4
2	N/A	N/A	N/A
3	RED	12VDC (+)	4
4	RED/WHITE	RIGHT BOX EXTEND	18
5	RED/BLACK	RIGHT BOX RETRACT	18
6	BLUE/WHITE	LEFT BOX EXTEND	18
7	BLUE/BLACK	LEFT BOX RETRACT	18
8	GREEN	RIGHT ANGLE	18
9	WHITE	LIFT	18
10	WHITE/BLACK	FLCAT	18
11	ORANGE	N/A	N/A
12	N/A	N/A	N/A
13	N/A	N/A	N/A
14	N/A	N/A	N/A
15	PINK/BLACK	12VDC (+) FUSED	18
16	N/A	N/A	N/A

PACKARD GT 280 ELECTRIC CONNECTOR (PLOW)			
PIN NO.	COLOR	FUNCTION	AWG
A	ORANGE/BLACK	(S5) LOWER/FLOAT	18
B	ORANGE/WHITE	(S7) LEFT/FLOAT	18
C	WHITE/BLACK	(S6) LIFT	18
D	ORANGE/RED	(S8) HITCH-LOWER	18
E	GREEN	(S4) ANGLE RIGHT	18
F	BLUE	(S3) ANGLE LEFT	18
G	BLUE/BLACK	(S9) LEFT SLIDE BOX RET.	18
H	BLUE/WHITE	(S10) LEFT SLIDE BOX EXT.	18
J	RED/BLACK	(S1) RIGHT SLIDE BOX RET.	18
K	RED/WHITE	(S2) RIGHT SLIDE BOX EXT.	18

PLASTIC ELECTRIC CONNECTOR, FEMALE - P/N 62046			
SILICONE RUBBER CABLE SEAL - P/N 62096			
FEMALE TERMINAL (18-16 AWG) - P/N 62093			

NOT DRAWN TO SCALE  
UNLESS OTHERWISE SPECIFIED  
ALL DIMENSIONS IN INCHES

### PLOW HARNESS (2003) WITH MOLDED PLUG P/N 62039

NOTE: SEE DETAIL ON PAGE 36.



END VIEW  
LOOKING AT CONNECTOR

END VIEW  
LOOKING AT CONNECTOR







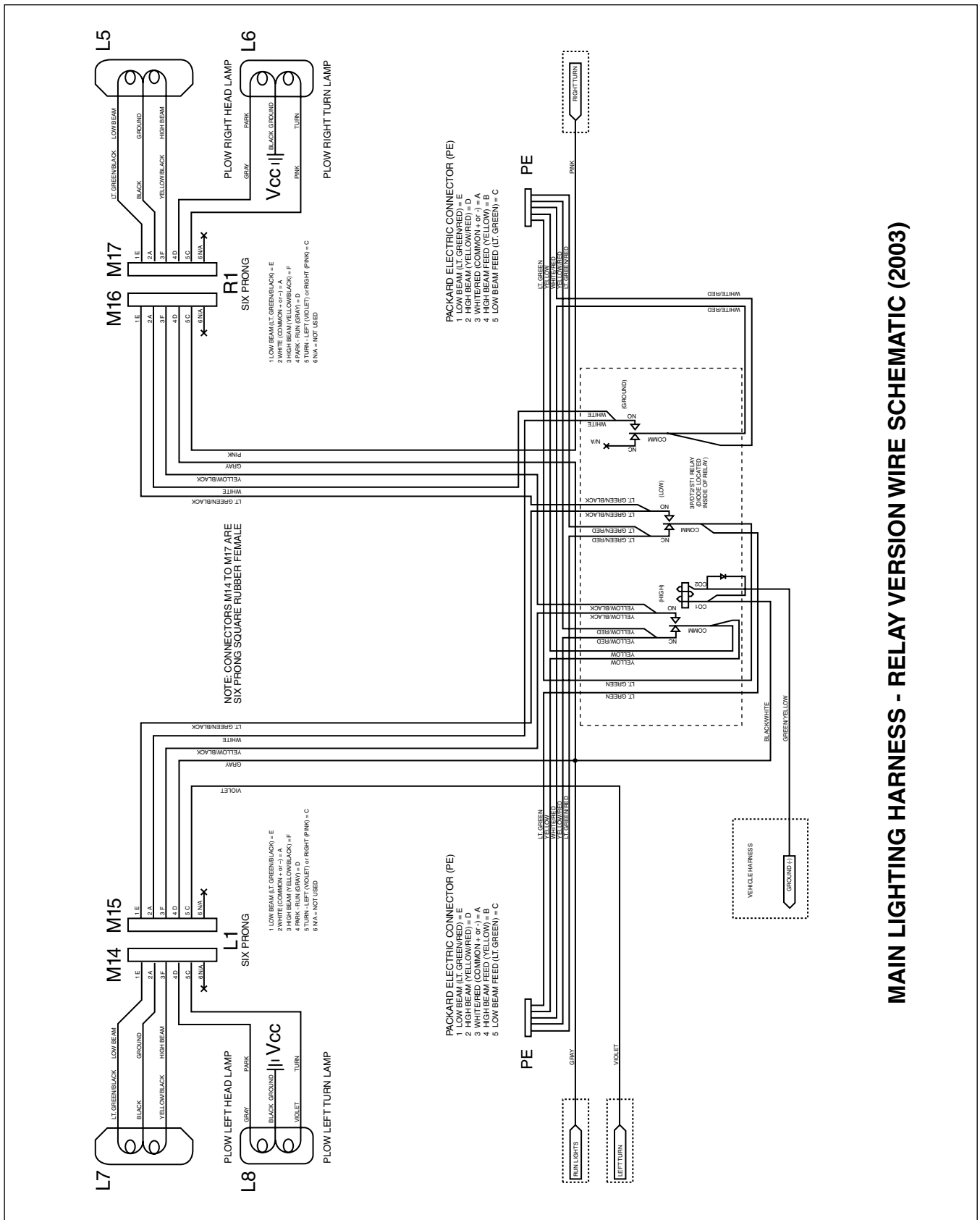

**MAIN LIGHTING HARNESS - RELAY VERSION WIRE SCHEMATIC (2003)**

PIN NO.	COLOR	FUNCTION	AWG
1	BLACK (A1)	GROUND	4
2	BLACK (B)	GROUND	18
3	BROWN/WHITE	PUMP SOLENOID TO RING	18
4	RED/WHITE	RIGHT BOX EXTEND	18
5	BLUE/WHITE	LEFT BOX EXTEND	18
6	BLACK/BLACK	RIGHT BOX RETRACT	18
7	BLUE/BLACK	LEFT BOX RETRACT	18
8	BLUE	RIGHT ANGLE	18
9	WHITE	LIFT	18
10	ORANGE	RIGHT ANGLE	18
11	ORANGE	LEFT ANGLE	18
12	N/A	FLOAT	N/A
13	N/A	N/A	N/A
14	N/A	N/A	N/A
15	PINK/BLACK	12 VDC (+) FUSED	N/A
16	N/A	N/A	N/A

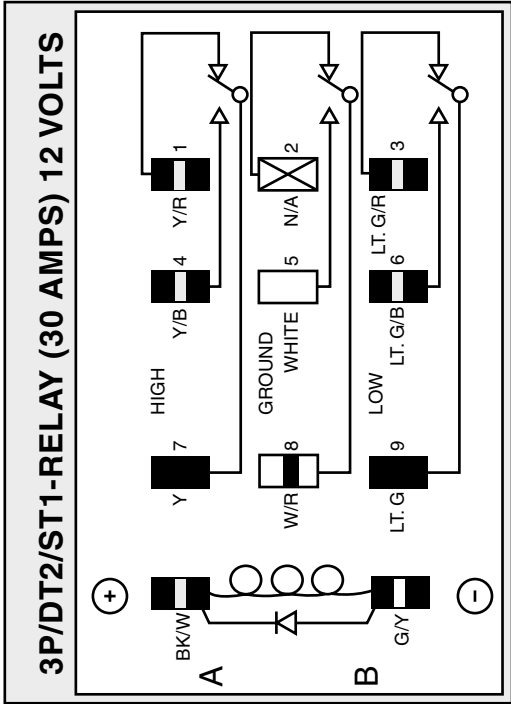

PIN NO.	COLOR	FUNCTION	AWG
1	RED/WHITE	RIGHT SLIDE BOX EXTEND	18
2	BLACK	SWITCH 12 VOLT +	18
3	RED	FLOAT	18
4	ORANGE	RIGHT SLIDE BOX EXTEND	18
5	BLUE/WHITE	LEFT SLIDE BOX EXTEND	18
6	BLACK/BLACK	RIGHT BOX RETRACT	18
7	BLACK	LEFT BOX RETRACT	18
8	WHITE	LIFT	18
9	BROWN/BLACK	PUMP SOLENOID	18
10	GREEN	RIGHT ANGLE	18
11	ORANGE	RIGHT ANGLE	18
12	BLUE	LEFT ANGLE	18

AAS-3 HEADLIGHT RELAY  
W/SURGE SUPPRESSION  
VENDOR P/N 90-9055-00-B-TR/SS  
BLIZZARD P/N 62125

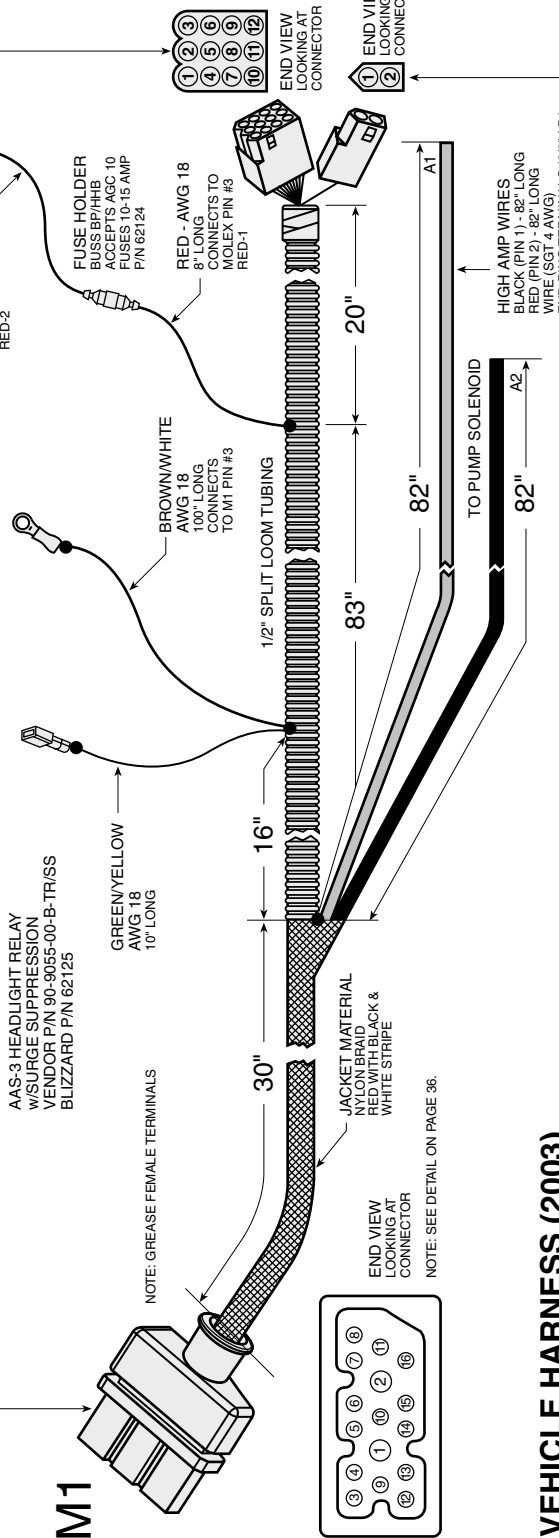

**VEHICLE HARNESS (2003)  
RELAY VERSION  
P/N 62111**

NOT DRAWN TO SCALE  
UNLESS OTHERWISE SPECIFIED  
ALL DIMENSIONS IN INCHES

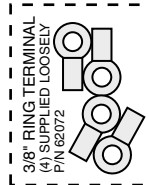

PIN NO.	COLOR	FUNCTION	AWG
1	GREEN/YELLOW	RELAY GROUND	18
2	N/A	N/A	N/A

PIN NO.	COLOR	FUNCTION	AWG
1	RED/WHITE	RIGHT SLIDE BOX EXTEND	18
2	BLACK	SWITCH 12 VOLT +	18
3	RED	FLOAT	18
4	ORANGE	RIGHT SLIDE BOX EXTEND	18
5	BLUE/WHITE	LEFT SLIDE BOX EXTEND	18
6	BLACK/BLACK	RIGHT BOX RETRACT	18
7	BLACK	LEFT BOX RETRACT	18
8	WHITE	LIFT	18
9	BROWN/BLACK	PUMP SOLENOID	18
10	GREEN	RIGHT ANGLE	18
11	ORANGE	RIGHT ANGLE	18
12	BLUE	LEFT ANGLE	18

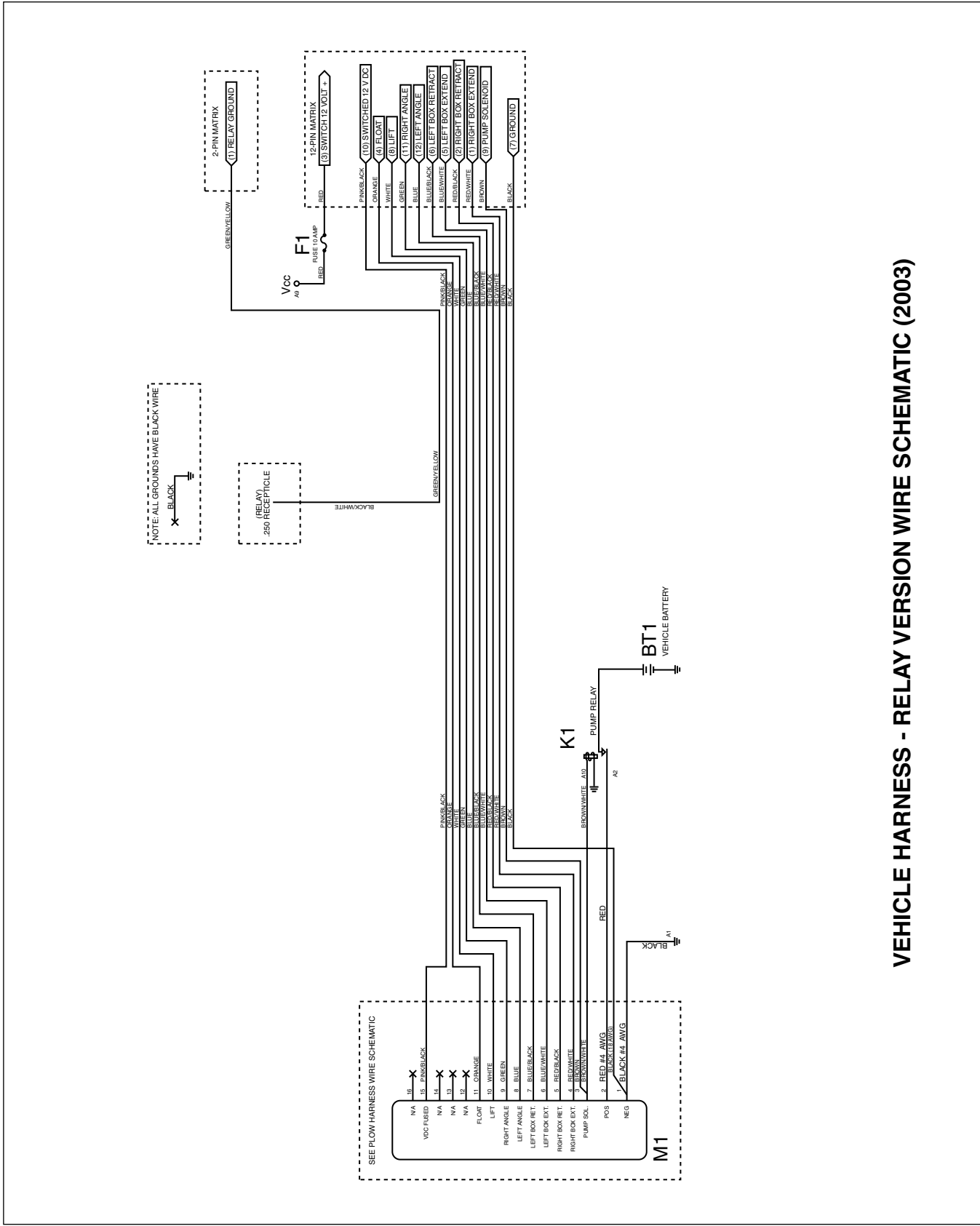

### VEHICLE HARNESS - RELAY VERSION WIRE SCHEMATIC (2003)

BLIZZARD HARNESS PLUG (VEHICLE) UNIVERSAL 14 + 2 MOLD			
PIN NO.	COLOR	FUNCTION	AWG
1	BLACK	GROUND	4
	BLACK	GROUND	18
2	RED	12 VOLT DC (+)	4
3	BROWN/WHITE	PUMP SOLENOID TO RING	18
	BROWN	PUMP SOLENOID TO MOLEX	18
4	RED/WHITE	RIGHT SLIDE BOX EXTEND	18
5	RED/BLACK	RIGHT SLIDE BOX RETRACT	18
6	BLUE/WHITE	LEFT SLIDE BOX EXTEND	18
7	BLUE/BLACK	LEFT SLIDE BOX RETRACT	18
8	BLUE	LEFT ANGLE	18
9	GREEN	RIGHT ANGLE	18
10	WHITE	LIFT	18
11	ORANGE	FLOAT	18
12	N/A	N/A	N/A
13	N/A	N/A	N/A
14	N/A	N/A	N/A
15	PINK/BLACK	12 (+) VDC FUSED	18
16	N/A	N/A	18

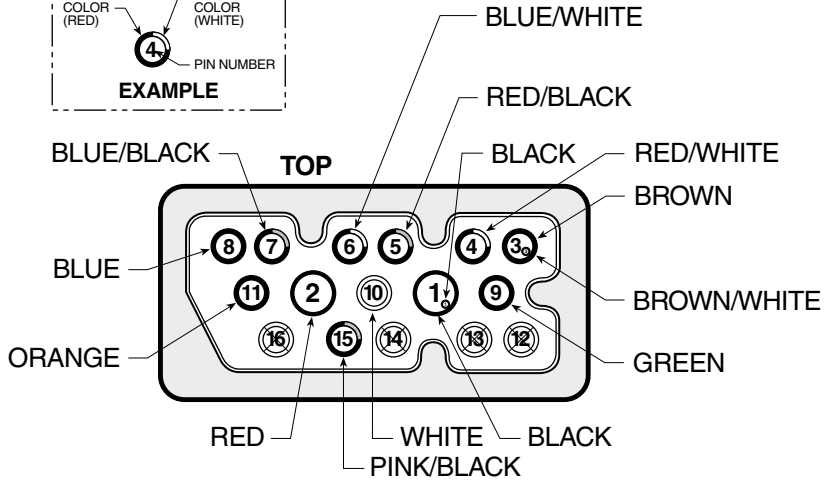
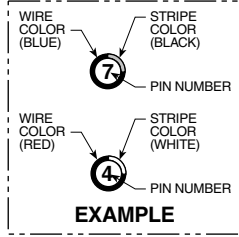
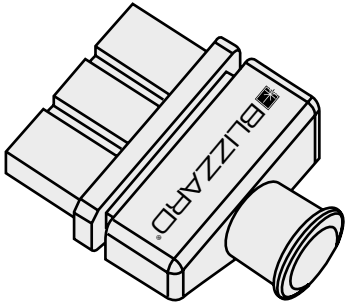

**VEHICLE HARNESS PLUG (2003)**  
FACE VIEW LOOKING AT FEMALE CONNECTOR  
FEMALE TERMINALS

BLIZZARD HARNESS PLUG (PLOW)			
PIN NO.	COLOR	FUNCTION	AWG
1	BLACK	GROUND	4
	N/A	N/A	N/A
2	RED	12 VOLT DC (+)	4
3	BROWN	PUMP SOLENOID	18
4	RED/WHITE	RIGHT SLIDE BOX EXTEND	18
5	RED/BLACK	RIGHT SLIDE BOX RETRACT	18
6	BLUE/WHITE	LEFT SLIDE BOX EXTEND	18
7	BLUE/BLACK	LEFT SLIDE BOX RETRACT	18
8	BLUE	LEFT ANGLE	18
9	GREEN	RIGHT ANGLE	18
10	WHITE	LIFT	18
	WHITE/BLACK	LIFT	18
11	ORANGE	FLOAT	18
12	N/A	N/A	N/A
13	N/A	N/A	N/A
14	N/A	N/A	N/A
15	PINK/BLACK	12 (+) VDC FUSED	18
16	N/A	N/A	18

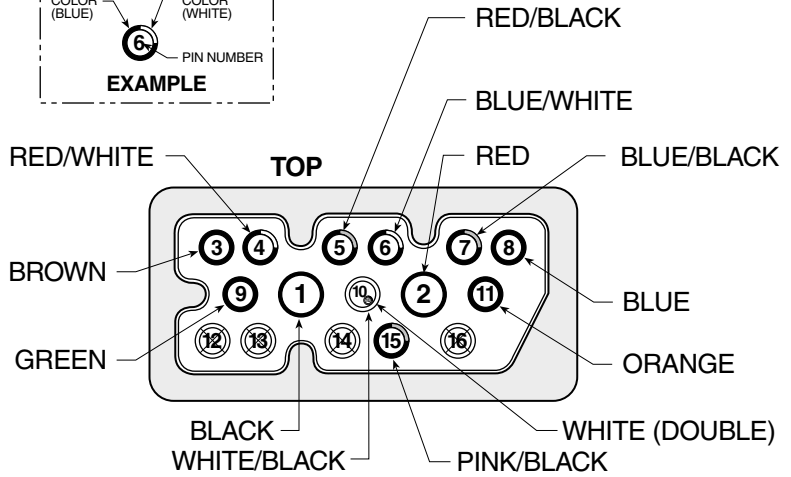
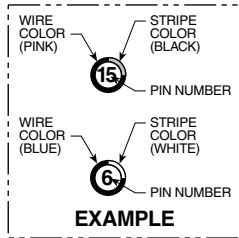
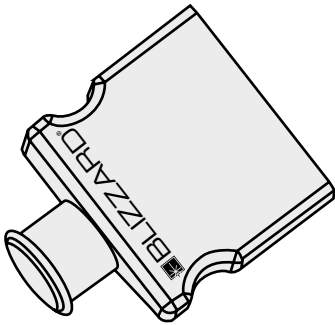

**PLOW HARNESS PLUG (2003)**  
FACE VIEW LOOKING AT MALE CONNECTOR  
MALE TERMINALS

# Troubleshooting Guide

Prior to diagnosing your Power Plow snowplow, verify that all connectors (plow and vehicle wire harness plugs, headlight adapters, control box, fused hot lead, draw latch switch, solenoid ground wire connection, coil wire lead harness, plow headlight harnesses) are free of corrosion and are well lubricated with dielectric grease. Insuring that all connectors are in good working order will save time in determining your snowplow's service needs.

Problem	Probable Cause(s)	Suggested Remedy
Pump will not run.	Plow wire harness may not be properly connected to the vehicle wire harness.	Verify the wire harnesses are properly connected. Review the instruction on pages 10-13.
	Power or ground cables to the battery, pump or solenoid may not be properly connected.	Properly connect all cables. Clean and lubricate with dielectric grease. If power does not resume, check the continuity of all cables to find the break.
Pump will not run, power to the solenoid.	The black ground wire and brown/white activation wire on the solenoid are not properly connected.	Properly connect both cables. Test for power by initiating any joystick function except the float. Note: The POWER rocker switch must be in the "ON" position to properly test any plow function. If the solenoid is grounded and no power exists, diagnose the plow & truck wire harnesses.
Pump will not run with power to the solenoid. Brown/white activation wire and ground are properly connected.	The red, hot wire to the pump motor is not properly connected.	Connect red wire and check the black ground wire. If problem is not resolved, the solenoid could be inoperable or the pump motor may be worn. Replace the solenoid if there is no power to the pump. Replace the pump motor if it is receiving power.
Pump will not turn off. Do not allow the pump motor to continuously run. Unplug the wire harness until the solenoid can be tested or a Blizzard Dealer can diagnose the problem.	Solenoid may be damaged.	Disconnect the brown/white activation wire from the solenoid. If the problem is not resolved, replace the solenoid.
	Short in the joystick control or wire harness.	Disconnect the joystick in the cab. If the pump turns off, there is a short in the electrical system.
Pump runs but plow functions are slow.	Fluid level in the pump reservoir is low. Fluid is leaking.	Add fluid to within 3/4" from the top of the tank. Check for leaks around the pump, manifold and cylinders.
	System pressure may be set too low. Increasing the pressure excessively will increase the amperage draw. This could damage the vehicle wire harness.	Adjust the pressure. Remove the hex cap on top of the pump and turn the screw clockwise. Proper system pressure should be set at 2400 PSI. Test functions and repeat procedure as needed.
	Amperage from the vehicle's alternator is too low.	Repair or replace vehicle alternator. System amperage draw is 150 Amps at 1500 PSI.
	Pump filter may be clogged.	Remove the pump tank and thoroughly clean the filter.
A-frame latch will not move.	Draw latch is binding the A-frame latch.	Lower the draw latch to relieve binding on the A-frame latch and reposition the A-frame latch as needed.
Plow will not lift. Pump works properly.	Control station in the cab may not be properly connected.	Connect the power connector from the control to the vehicle wire harness.
	A-frame latch is in the (down) locked position.	Lift the A-frame latch into the raised position.
	Diode pack may be corroded or could have failed.	Clean diode pack thoroughly and/or replace.

<b>Problem</b>	<b>Probable Cause(s)</b>	<b>Suggested Remedy</b>
Plow will not lift. Pump works properly. (Continued from page 37.)	Coils on the manifold may be damaged.	Remove the S6 coil from the cartridge valve. Position a screwdriver inside of the coil and push the draw latch connect/disconnect toggle switch upward. The screwdriver should be magnetically drawn to the coil. Replace the coil if there is no action.
Plow will not lift with magnification to the S6 coil.	Hydraulic lock in the manifold. This occurs if the voltage is too low on the coils – should be 10 volts.	Loosen cartridge valve S6 to relieve pressure and retighten. DO NOT OVERTIGHTEN! Valves should be torqued to a maximum of 24 ft. lbs.
	Solenoid cartridge valve may be contaminated.	Remove any foreign objects that may be obstructing proper valve operation. Replace if not operating properly after cleaning.
Plow will not stay angled when plowing.	The angle pressure relief valve is set too low. NOTE: Increasing the pressure relief valve will cause damage to your plow. Do not set the pressure relief greater than 3000 PSI (See illustration on page 39.).	Check the pressure relief by testing the valve inline with the cylinder. Attach a tee fitting to the angle cylinder hydraulic adapter and connect the hose and pressure gauge to the tee. Push the plow against a solid object and record the pressure reading. Note: The setting should not exceed 3000 PSI.
Plow will not angle, pump works.	Review all probable causes above.	NOTE: Verify coils S3 & S4 for angle functions.
Wing will not stay angled when plowing.	The angle pressure relief valve is set too low. Note: Increasing the pressure relief valve will cause damage to your plow. Do not set the pressure relief greater than 1700 PSI.	Test the wing pressure relief. Attach a fluid PSI gauge to the quick connect fitting on the manifold. The pressure relief should not be greater than 1700 PSI. Review the illustration on page 39 to increase the pressure relief settings.
Wing will not move, pump works.	Control station, wire harness or cables may be loose or improperly connected.	Verify control station, wire harness and all cables are securely connected. Clean if necessary.
	Hydraulic lock in the manifold has occurred.	Loosen cartridge valves S9 & S10 or S1 & S2 to relieve pressure and retighten. DO NOT OVERTIGHTEN! Valves should be torqued to a maximum of 24 ft. lbs.
	No power to the coils.	Verify coils S1 & S2 (pass. side slide box retract and extend) and S9 & S10 (drive. side slide box retract and extend) are grounded, connected properly and receiving power. If no power is available, diagnose the wire harness. Review the plow wire harness schematic on page 31 and the vehicle wire schematic on pages 33 & 35. If power is present, review the next step.
	Coils are receiving power.	Verify coils are magnetizing. Position a screwdriver inside of the coil. When the respective function is activated, the screwdriver is drawn to the side of the coil. If the coil is not drawn to the screwdriver, replace the coil. If power is present, review the next step.
	Solenoid cartridge may be contaminated or damaged. A bent cartridge will not allow the valve to move freely inside of the cartridge.	Determine a damaged cartridge valve by reversing the driver's side and passenger's side cartridge valves. Replace valve if necessary.
Plow lowers too slow.	Variable flow control valve is not adjusted properly. (See illustration on page 39)	Turn flow control valve counterclockwise in small increments and test. NOTE: Never make adjustments when the plow is in the raised position! Fluid pressure will make the valve difficult to adjust and serious injury or death can occur from a falling plow.
	Review all probable causes for plow will not lift (Page 37).	Verify S5 coil (float) or S5 & S8 coils (disconnect) for magnetism.



Problem	Probable Cause(s)	Suggested Remedy
Plow drops sporadically.	Variable flow control valve is opened too far.	Turn clockwise 1/16 of a turn and test. NOTE: Never make adjustments when the plow is in the raised position! Fluid pressure will make the valve difficult to adjust and serious injury or death can occur from a falling plow.
Headlights will not switch from the vehicle to the snowplow.	No power or ground to the headlight relay.	Verify green/yellow (G/Y) wire for the ground is connected. Verify black/white (BK/W) wire for the power is connected. If both are connected properly, replace the headlight relay.

Should your snowplow develop other problems not indicated in the Troubleshooting Guide, contact your local dealer for technical assistance and/or replacement parts.

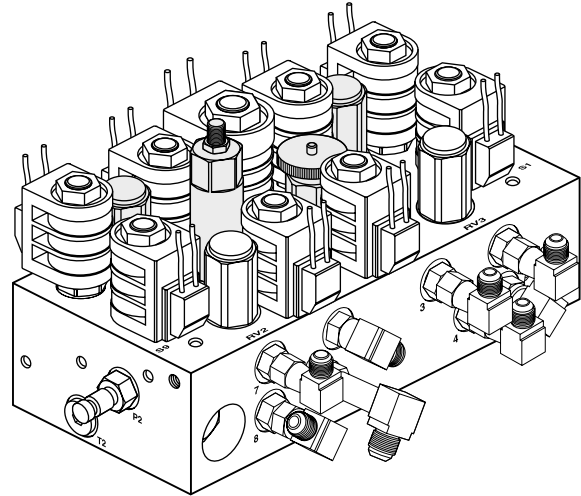
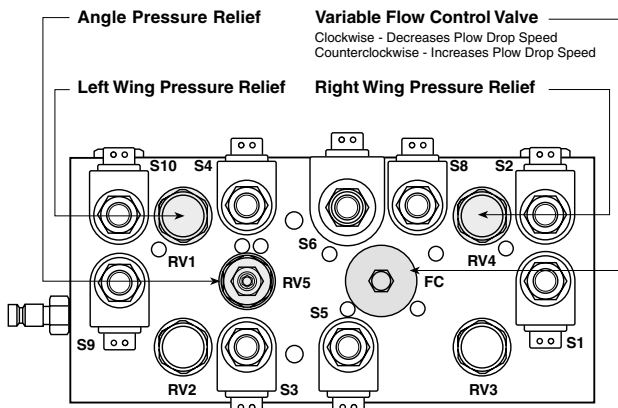



## LIMITED CONSUMER WARRANTY

This warranty covers defects in material and workmanship except as set forth below.

### WARRANTED PARTY:

This warranty applies only to the "Original Purchaser" who purchased this plow from an Authorized Blizzard Dealer, for personal, family or household use.

### TERM OF WARRANTY:

This Blizzard Power Plow snowplow is warranted for the following period:  
Parts and labor are warranted for one year from date of purchase.

### BLIZZARD CORPORATION'S WARRANTY REMEDY:

Blizzard Corporation will, at its sole discretion, repair or replace defective parts at no charge.

### CUSTOMERS RESPONSIBILITY:

To obtain warranty service, the purchaser must return the defective snowplow to any Authorized Blizzard Dealer. The purchaser must verify the original purchase date. Transportation costs to and from the dealer will be the responsibility of the purchaser.

### ITEMS NOT COVERED UNDER THIS WARRANTY:

This limited warranty does not cover the following:

1. Expendable parts such as cutting edges, plow shoes, hoses, fasteners, blade guides, paint finish, etc.
2. Any snowplow or part thereof which has been repaired or altered by anyone other than an Authorized Blizzard Dealer.
3. Any snowplow or part thereof which has been subject to neglect, misuse, accident, improper installation, maintenance, or storage. This includes, but is not limited to, corrosion of any electrical components.
4. Snowplows mounted on vehicles other than those for whom Blizzard Corporation has provided a specific undercarriage system.
5. Blizzard Corporation does not assume liability for damage to the purchaser's vehicle resulting from the attachment and use of a Blizzard Power Plow snowplow. Vehicle risk is the sole responsibility of the purchaser.

### WARRANTY LIMITATIONS:

THIS WARRANTY IS OFFERED IN LIEU OF ANY OTHER EXPRESS WARRANTY.

THE DURATION OF ALL IMPLIED WARRANTIES, INCLUDING BUT NOT LIMITED TO THE IMPLIED WARRANTIES OF MERCHANTABILITY AND FITNESS FOR A PARTICULAR PURPOSE, ARE LIMITED TO THE DURATION OF THIS WARRANTY.

BLIZZARD CORPORATION'S LIABILITY IS EXPRESSLY LIMITED TO REPAIR OR REPLACEMENT OF DEFECTIVE PARTS. BLIZZARD CORPORATION SHALL NOT BE LIABLE FOR CONSEQUENTIAL, INCIDENTAL OR CONTINGENT DAMAGES WHATSOEVER, EVEN IF DAMAGES ARE CAUSED BY THE NEGLIGENCE OR FAULT OF BLIZZARD CORPORATION.

**State Laws:** Some states do not allow exclusion of incidental or consequential damages or the limitations on how long an implied warranty lasts, so these limitations or exclusions may not apply to you. This warranty gives you specific legal rights and you may also have other rights which vary from state to state.

This warranty does not apply if you purchased your snowplow for other than personal, family, or household use. If purchased for other than personal, family or household use, refer to the Blizzard Power Plow Commercial Warranty.



95 AIRPARK BOULEVARD ■ CALUMET, MICHIGAN 49913 ■ (906) 482-5555

1029-7-99 REV 8/01



## COMMERCIAL WARRANTY

This warranty covers defects in material and workmanship except as set forth below.

### WARRANTED PARTY:

This warranty applies only to the "Original Purchaser" who purchased this plow from an Authorized Blizzard Dealer, for commercial use.

### TERM OF WARRANTY:

This Blizzard Power Plow snowplow is warranted for the following period:  
Parts and labor are warranted for one year from date of purchase.

### BLIZZARD CORPORATION'S WARRANTY REMEDY:

Blizzard Corporation will, at its sole discretion, repair or replace defective parts at no charge.

### CUSTOMERS RESPONSIBILITY:

To obtain warranty service, the purchaser must return the defective snowplow to any Authorized Blizzard Dealer within the warranty period. The purchaser must verify the original purchase date. Transportation costs to and from the Dealer will be the responsibility of the purchaser.

### ITEMS NOT COVERED UNDER THIS WARRANTY:

This warranty does not cover the following:

1. Expendable parts such as cutting edges, plow shoes, hoses, fasteners, blade guides, paint finish, etc.
2. Any snowplow or part thereof which has been repaired or altered by anyone other than an Authorized Blizzard Dealer.
3. Any snowplow or part thereof which has been subject to neglect, misuse, accident, improper installation, maintenance, or storage. This includes, but is not limited to, corrosion of any electrical components.
4. Snowplows mounted on vehicles other than those for whom Blizzard Corporation has provided a specific undercarriage system.
5. Blizzard Corporation does not assume liability for damage to the purchaser's vehicle resulting from the attachment and use of a Blizzard Power Plow snowplow. Vehicle risk is the sole responsibility of the purchaser.

### LIMITS OF BLIZZARD CORPORATION'S LIABILITIES:

BLIZZARD CORPORATION'S LIABILITY IS EXPRESSLY LIMITED TO REPAIR OR REPLACEMENT OF DEFECTIVE PARTS. BLIZZARD CORPORATION SHALL NOT BE LIABLE FOR CONSEQUENTIAL, INCIDENTAL OR CONTINGENT DAMAGES WHATSOEVER, EVEN IF DAMAGES ARE CAUSED BY THE NEGLIGENCE OR FAULT OF BLIZZARD CORPORATION.

THE FOREGOING WARRANTIES ARE EXCLUSIVE AND IN LIEU OF ALL OTHER EXPRESSED AND IMPLIED WARRANTIES INCLUDING, BUT NOT LIMITED TO, THE IMPLIED WARRANTIES OF MERCHANTABILITY AND FITNESS FOR A PARTICULAR PURPOSE.

This warranty does not apply if you purchased your snowplow for personal, family, or household use. In this case, refer to the Blizzard Power Plow Limited Consumer Warranty.



95 AIRPARK BOULEVARD ■ CALUMET, MICHIGAN 49913 ■ (906) 482-5555

1030-7-99 REV 8/01

# MODEL 810



95 Airpark Boulevard  
Calumet, MI 49913  
[888] 680-8600  
[906] 482-5555  
[906] 482-5445 Fax  
[www.blizzardplows.com](http://www.blizzardplows.com)

Blizzard, Power Plow, Blizzard Power Plow, WidePass, BucketBlade, Power Hitch and Seat Cinch are trademarks of Blizzard Corporation. Blizzard is registered in the United States Patent and Trademark Office. Loctite and 242 are registered trademarks of Loctite Corporation, USA. Velcro is a registered trademark of Velcro Industries B.V. All other trademarks and registered trademarks are the property of their respective owners. All Blizzard snowplows are protected by one or more of the following United States Patents: 5,638,618; 5,899,007; 6,178,869; 6,276,076 and 6,393,737; Other patents pending. Copyright © 2003 Blizzard Corporation. All rights reserved. Made and printed in the USA.1302-04-03