

BLIZZARD[®] **SNOWPLOWS**

SPEEDWING[™] Snowplow

Model 8600SW

Owner's Manual
Original Instructions

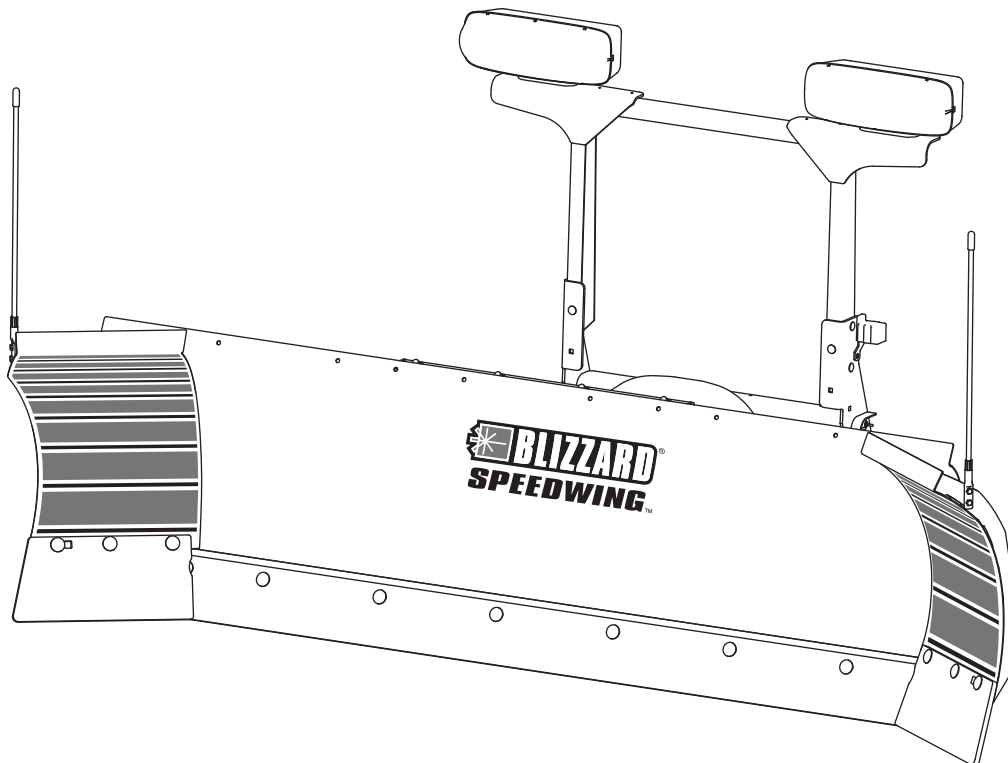

⚠ CAUTION

**Read this manual before operating or
servicing the snowplow.**

This Owner's Manual is for BLIZZARD[®] SPEEDWING snowplows with serial numbers beginning with 120202 and higher.

SNOWPLOW OWNER DATA SHEET

Register your snowplow online at www.blizzardplows.com

Owner Name: _____

Date Purchased: _____

Dealer Name: _____ Phone: _____

Dealer Address: _____

Vehicle Model/Year: _____

Snowplow Model/Year: _____

Snowplow Type/Size: _____ Weight: _____ lb/kg

Ballast: No ___ Yes ___ Amount: _____ lb/kg

Hydraulic Unit Serial Number: _____

Blade Serial Number: _____

TABLE OF CONTENTS

PREFACE	7	REMOVING SNOWPLOW FROM VEHICLE & STORAGE	32
SAFETY	8	MAINTENANCE	34
VEHICLE APPLICATION INFORMATION	11	Aiming Headlamp Beams.....	34
Ballast Requirements.....	11	Preseason Check.....	35
GETTING TO KNOW YOUR SNOWPLOW	12	Postseason Maintenance.....	35
Snowplow Headlamps.....	12	Maintenance and Adjustment.....	36
Vehicle Mount.....	12	Hydraulic System.....	37
Hydraulic System.....	13	Fluid Level.....	37
System Capacity.....	13	Annual Fluid Change.....	38
Pump Motor Specifications.....	13	Fuse Replacement.....	39
Cab Controls.....	13	Vehicle.....	39
FLEET FLEX Electrical System.....	14	Recycle.....	39
SECURITY GUARD™ System.....	14	Blade Finish.....	39
Smooth Stop.....	16	Emergency Parts/Tools.....	39
One-Touch Float.....	16	Troubleshooting.....	39
ACCESSORIES & OPTIONS	17	TECHNICAL SPECIFICATIONS	40
MOUNTING SNOWPLOW TO VEHICLE	19	HARNES DIAGRAM	41
OPERATING YOUR SNOWPLOW	20		
Joystick Control.....	20		
POWER GRIP™ Hand-Held Control.....	22		
Plowing Positions.....	24		
Snowplow Headlamp Check.....	25		
Disc Shoe Adjustment.....	26		
Hydraulic System.....	27		
Blade Drop Speed Adjustment.....	28		
Transporting the Snowplow.....	29		
Driving and Plowing on Snow and Ice.....	30		
Plowing Snow.....	30		
General Instructions.....	30		
Hard-Packed Snow.....	31		
Deep Snow.....	31		
Clearing Driveways.....	31		
Clearing Parking Lots.....	31		
Parking with Snowplow Attached.....	31		
Towing a Disabled or Stuck Vehicle.....	31		

PREFACE

PREFACE

Congratulations on purchasing the newest innovation in snowplowing available! BLIZZARD® SPEEDWING™ blades create a whole new category for multi-position truck-mounted snowplows. Our innovative products are tested all over the snowbelt.

This manual provides safety, operation, and maintenance information for your new BLIZZARD snowplow. To keep your snowplow in good condition, read and understand this manual and follow its recommendations. Failure to do so may affect your warranty coverage.

When service is necessary, your local BLIZZARD dealer knows your snowplow best. Contact your BLIZZARD outlet for maintenance, service, or any other assistance you may require.

If you have not already done so, please visit www.blizzardplows.com to register your new BLIZZARD snowplow!

AUTHENTIC PARTS AND ACCESSORIES

Your BLIZZARD snowplow is a valuable investment. The best way to assure original equipment reliability and efficiency is to purchase only **Authentic Parts and Accessories**. "Will-fit" parts and accessories can alter your snowplow's performance characteristics and may affect your product warranty.

Protect your investment by staying with the best—original BLIZZARD parts and accessories from your local BLIZZARD outlet.



SAFETY

SAFETY DEFINITIONS

⚠ WARNING

Indicates a potentially hazardous situation that, if not avoided, could result in death or serious personal injury.

⚠ CAUTION

Indicates a potentially hazardous situation that, if not avoided, may result in minor or moderate injury. It may also be used to alert against unsafe practices.

NOTE: Indicates a situation or action that can lead to damage to your snowplow and vehicle or other property. Other useful information can also be described.

WARNING/CAUTION AND INSTRUCTION LABELS

Become familiar with and inform users about the warning/caution, serial number, and instruction labels on the back of the blade.

NOTE: If labels are missing or cannot be read, see your sales outlet.

Instruction Label

ATTACH

- Slowly drive vehicle forward to engage mount adapter into A-frame.
- Move power switch to center or "OFF" position.
- Plug in electrical harnesses.
- Push and hold power switch RIGHT and push UP and hold arm/blade operation switch. Arm will engage mount adapter and pull snowplow toward vehicle.
- Rotate and release hitch pin. Hitch pin is fully engaged when pin handle is against the pin guide plate.
- Repeat Step 5 on passenger's side. Rotate and release hitch pin. Hitch pin is fully engaged when pin handle is against the pin guide plate.
- While holding power switch RIGHT, push DOWN and hold arm/blade operation switch. Arm will disengage mount adapter to relieve tension on the stand.
- Pull stand handle up. Stand will lift off ground. Pull stand pin out. Rotate stand up until stand pin seats into upper hole. Pin must lock into upper A-frame hole.
- Repeat Step 8 on passenger's side. Pull stand handle up. Stand will lift off ground. Pull stand pin out. Rotate stand up until stand pin seats into upper hole. Pin must lock into upper A-frame hole.
- Move power switch to left or "Plowing" position.

⚠ WARNING

Keep fingers away from snowplow and truck attachment points. POWER HITCH™ 2 arm raises behind undercarriage pushbeam.

DETACH

- Lower snowplow onto ground with blade straight. Turn snowplow control to OFF.
- Move power switch to center or "OFF" position.
- While holding the power switch RIGHT, push DOWN and hold the arm/blade operation switch. Arm will disengage mount adapter to relieve tension on the stand.
- Pull stand pin out. Rotate stand down until stand pin seats into lower A-frame hole. Push down on top of shoe. Shoe will be on the ground.
- Repeat Step 4 on passenger's side. Pull stand pin out. Rotate stand down until stand pin seats into lower A-frame hole. Push down on top of shoe. Shoe will be on the ground.
- Push and hold power switch RIGHT and push UP the arm/blade operation switch. Arm will engage mount adapter and pull snowplow tightly to vehicle.
- Rotate and pull hitch pin. Rotate hitch pin into retracted position.
- Repeat Step 7 on passenger's side. Rotate and pull hitch pin. Rotate hitch pin into retracted position.
- While holding power switch RIGHT, push DOWN and hold arm/blade operation switch to fully lower arm.
- Unplug electrical harnesses.

POWER HITCH 2 **BLIZZARD**

Read Owner's Manual for complete instructions.
US patents: 6,616,513; 7,134,227; 7,430,638; 7,430,821; 7,737,576; CAN patents: 2,350,145; 2,468,544; 2,468,195; and other patents pending.

Warning/Caution Label

⚠ WARNING

Blade could drop unexpectedly, crushing or trapping limbs. Lower blade when vehicle is parked.

Overloading could negatively affect vehicle handling. To avoid serious injury or death, do not exceed GVWR or GAWR including blade and ballast.

⚠ CAUTION

Read Owner's Manual before operating or servicing snowplow.

Transport speed should not exceed 45 mph (72 km/h). Further reduce speed under adverse travel conditions.

Plowing speed should not exceed 10 mph (16 km/h).

See your sales outlet/website for specific vehicle application recommendations.

Warning Label

⚠ WARNING

Crush hazard

Keep feet clear

Warning Label

⚠ WARNING

Multiple Pinch Points

(both sides)

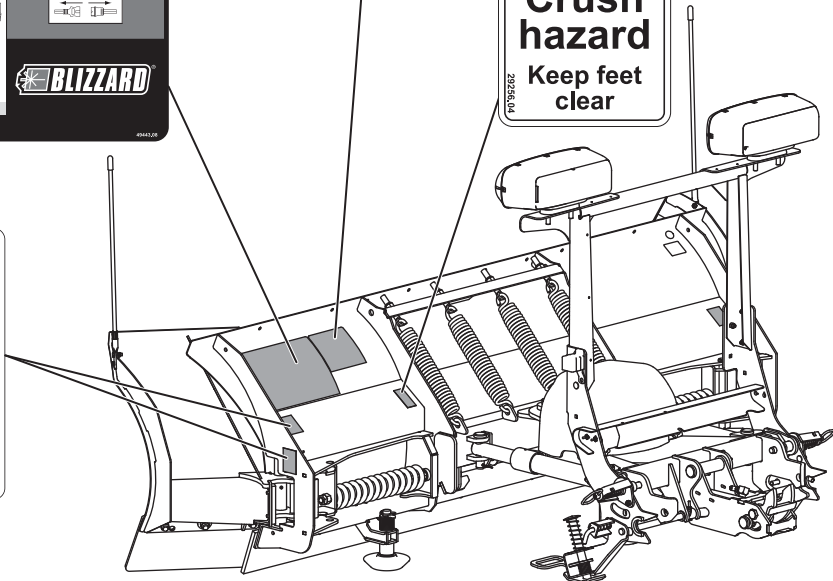

SAFETY

Blade Serial Number Label

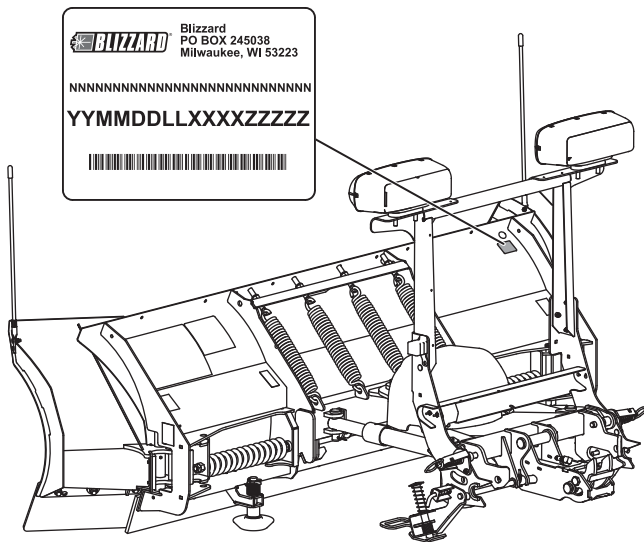

Code	Definition
YY	2-Digit Year
MM	2-Digit Month
DD	2-Digit Day
LL	2-Digit Location Code
XXXX	4-Digit Sequential Number
ZZZZZ	5- to 7-Digit Blade Assembly PN

SAFETY PRECAUTIONS

Improper installation and operation could cause personal injury, and/or equipment and property damage. Read and understand labels and the Owner's Manual before installing, operating, or making adjustments.

⚠ WARNING

Lower the blade when the vehicle is parked. Temperature changes could change hydraulic pressure, causing the blade to drop unexpectedly or damaging hydraulic components. Failure to do this could result in serious personal injury.

⚠ WARNING



Do not exceed GVWR or GAWR including the blade and ballast. The rating label is found on the driver-side vehicle door cornerpost.

⚠ WARNING

To prevent accidental movement of the blade, always turn the control OFF whenever the snowplow is not in use. The power indicator light will turn OFF.

⚠ WARNING

Remove blade assembly before placing vehicle on hoist.

⚠ CAUTION

Read Owner's Manual before operating or servicing snowplow.

⚠ CAUTION

Transport speed should not exceed 45 mph (72 km/h). Further reduce speed under adverse travel conditions.

⚠ CAUTION

Plowing speed should not exceed 10 mph (16 km/h).

⚠ CAUTION

See your BLIZZARD® outlet for application recommendations.

HYDRAULIC SAFETY

⚠ WARNING



Hydraulic fluid under pressure can cause skin injection injury. If you are injured by hydraulic fluid, get medical attention immediately.

- Always inspect hydraulic components and hoses before using. Replace any damaged or worn parts immediately.
- If you suspect a hose leak, DO NOT use your hand to locate it. Use a piece of cardboard or wood.

SAFETY

FUSES

The BLIZZARD® electrical and hydraulic systems contain several automotive-style fuses. If a problem should occur and fuse replacement is necessary, the replacement fuse must be of the same type and amperage rating as the original. Installing a fuse with a higher rating can damage the system and could start a fire. Fuse Replacement, including fuse ratings and locations, is located in the Maintenance section of this Owner's Manual.

PERSONAL SAFETY

- Remove ignition key and put the vehicle in PARK or in gear to prevent others from starting the vehicle during installation or service.
- Wear only snug-fitting clothing while working on your vehicle or snowplow.
- Do not wear jewelry or a necktie, and secure long hair.
- Wear safety goggles to protect your eyes from battery acid, gasoline, dirt, and dust.
- Avoid touching hot surfaces such as the engine, radiator, hoses, and exhaust pipes.
- Always have a fire extinguisher handy, rated BC for flammable liquids and electrical fires.

FIRE AND EXPLOSION

⚠ WARNING

Gasoline is highly flammable and gasoline vapor is explosive. Never smoke while working on vehicle. Keep all open flames away from gasoline tank and lines. Wipe up any spilled gasoline immediately.

Be careful when using gasoline. Do not use gasoline to clean parts. Store only in approved containers away from sources of heat or flame.

CELL PHONES

A driver's first responsibility is the safe operation of the vehicle. The most important thing you can do to prevent a crash is to avoid distractions and pay attention to the road. Wait until it is safe to operate mobile communication equipment such as cell phones, text messaging devices, pagers, or two-way radios.

VENTILATION

⚠ WARNING

Vehicle exhaust contains lethal fumes. Breathing these fumes, even in low concentrations, can cause death. Never operate a vehicle in an enclosed area without venting exhaust to the outside.

BATTERY SAFETY

⚠ CAUTION

Batteries normally produce explosive gases, which can cause personal injury. Therefore, do not allow flames, sparks, or lit tobacco to come near the battery. When charging or working near a battery, always cover your face and protect your eyes, and also provide ventilation.

- Batteries contain sulfuric acid, which burns skin, eyes, and clothing.
- Disconnect the battery before removing or replacing any electrical components.

NOISE

Airborne noise emission during use is below 70 dB(A) for the snowplow operator.

VIBRATION

Operating snowplow vibration does not exceed 2.5 m/s² to the hand-arm or 0.5 m/s² to the whole body.

SNOWPLOW BLADE ASSEMBLY WEIGHT

Weights: Big Box Assembly with Blade			
Size	Blade Assembly	Wt (lb)	Wt (kg)
8'6"	8600 SPEEDWING™	852	386

VEHICLE APPLICATION INFORMATION

⚠ CAUTION

See your BLIZZARD® outlet for specific vehicle application recommendations before installation. The Power Match selection system has specific vehicle and snowplow requirements.

Vehicle application recommendations are based on the following:

- The vehicle with the snowplow installed must comply with applicable Federal Motor Vehicle Safety Standards (FMVSS).
- The vehicle with the snowplow installed must comply with the vehicle manufacturer's stated gross vehicle and axle weight ratings (found on the driver-side door cornerpost of the vehicle) and the front and rear weight distribution ratio. In some cases, rear ballast may be required to comply with these requirements. See "Ballast Requirements" in this section.
- BLIZZARD Power Match selection system is based on available vehicle capacity for snowplow equipment on a representative vehicle equipped with options commonly used for plowing and with 300 lb of front seat occupant weight.
- Weights of front seat occupants can be adjusted above 300 lb, but vehicle with snowplow must not exceed vehicle GVWR or GAWR.
- In some cases there may be additional limitations and requirements.
- Installation, modification and addition of accessories must comply with published BLIZZARD recommendations and instructions. Available capacity decreases as the vehicle is loaded with cargo or other truck equipment, or as snowplow accessories are installed.
- If there is uncertainty as to whether available capacity exists, the actual vehicle as configured must be weighed.

BALLAST REQUIREMENTS

Ballast (additional weight) is an important part of qualifying vehicles for snowplow eligibility. Rear ballast must be used when necessary to remain in compliance with axle ratings and ratios as specified by the vehicle manufacturer.

If ballast is required, it is important that it be secured properly behind the rear axle. A ballast retainer kit is available from your BLIZZARD outlet, PN 62849.

NOTE: The ballast retainer kit is for snowplow vehicles requiring ballast. See your BLIZZARD outlet for the correct amount of ballast required. Include the weight of the retainer as part of the ballast requirement. Sandbags are recommended for use as ballast.

NOTE: Ballast recommended and its weight calculations assume the entire width of the bed is filled as close to tailgate as possible.

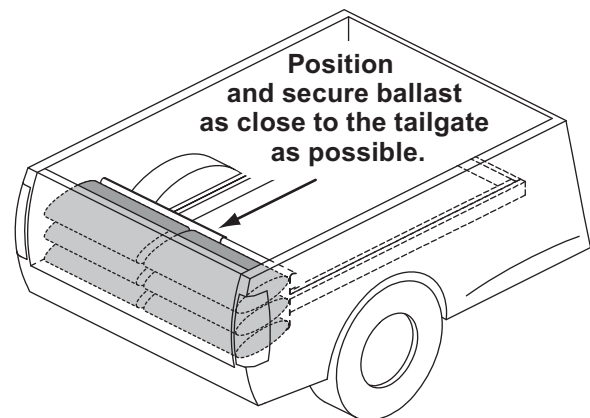

GETTING TO KNOW YOUR SNOWPLOW

SNOWPLOW HEADLAMPS

⚠ WARNING

Your vehicle must be equipped with snowplow headlamps and directional lights.

The snowplow headlamps feature state-of-the-art optics with long-life (H13) halogen bulbs, combination park/turn signals, and dual mounting studs. A prewired harness with a plug-in module requires no headlamp wire splicing. The headlamps conform to Federal Motor Vehicle Safety Standards (FMVSS).

When the electrical plugs are connected, the vehicle headlamps will automatically switch to the snowplow headlamps when they are turned ON. When the electrical plugs are disconnected, the headlamps will automatically switch to vehicle headlamps when they are turned ON.

Replacement parts are available through your local BLIZZARD® outlet.

VEHICLE MOUNT

Blizzard has designed custom mounts for most vehicles. Due to differences among vehicle models, mounts are generally not interchangeable.

The mount is fastened to the underside of the vehicle frame and provides the primary connecting point between the snowplow and the vehicle.

Attached to the mount is a removable mount adapter. The mount adapter is attached to the mount with clevis pins and hairpin cotters. The mount adapter is easily removed to provide even more road clearance during the nonplowing months of the year.

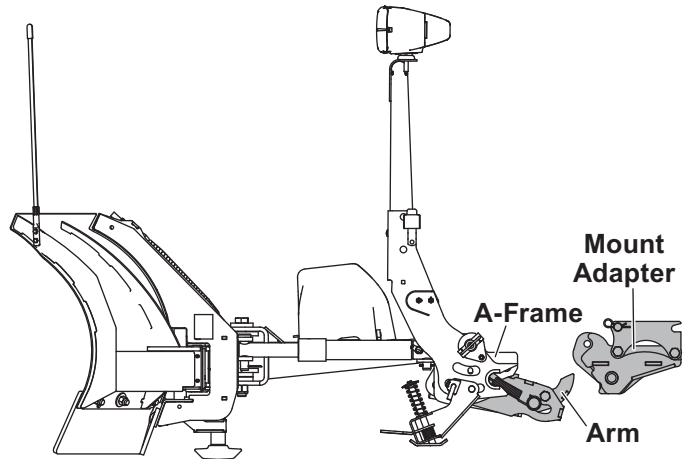

GETTING TO KNOW YOUR SNOWPLOW

HYDRAULIC SYSTEM

The hydraulic unit delivers fast and uniform speed for lifting and angling. BLIZZARD® SPEEDWING™ blades are raised in approximately 3 seconds and angled side to side in approximately 3 seconds.

For hydraulic fluid type and filling instructions, see "Annual Fluid Change" in the Maintenance section of this manual.

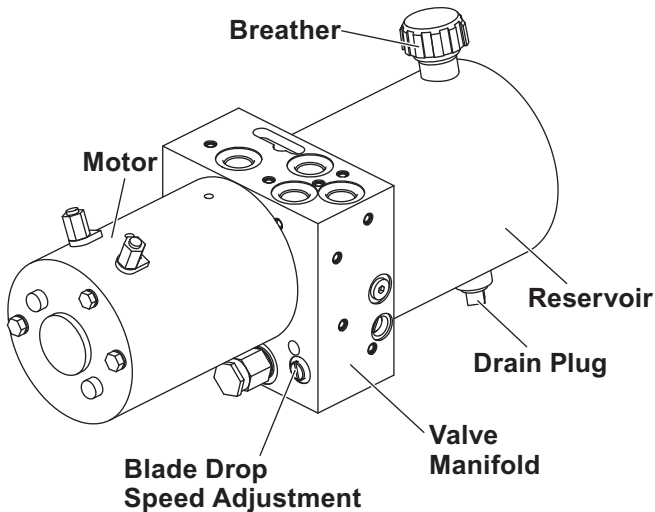

System Capacity

- Unit Reservoir 1-3/4 quarts
- System Total 3 to 3-1/4 quarts

Pump Motor Specifications

12V DC with +/- connection
1600–1700 psi pump relief valve
3000 psi angling relief valve
4.5" dia 1.5 kW motor
0.000652 gal/rev pump
Hydraulic hose SAE 100R1

CAB CONTROLS

⚠ WARNING

To prevent accidental movement of the blade, always turn the control OFF whenever the snowplow is not in use. The power indicator light will turn OFF.

BLIZZARD snowplows come equipped with one of two special controls: the POWER GRIP™ hand-held control or a joystick-style control.

Each control has its own ON/OFF switch with an indicator light to show when the control is powered up. Your vehicle ignition (key) switch controls a fused circuit that powers your cab control directly from the battery.

The ON/OFF switch on the cab control allows you to turn OFF the control and prevent blade movement even when the ignition switch is ON.

The control ON/OFF switch serves as an emergency stop if required.

All controls are protected by a replaceable fuse located in the under hood snowplow electrical system. See "Fuse Replacement" in the Maintenance section of this Owner's Manual.

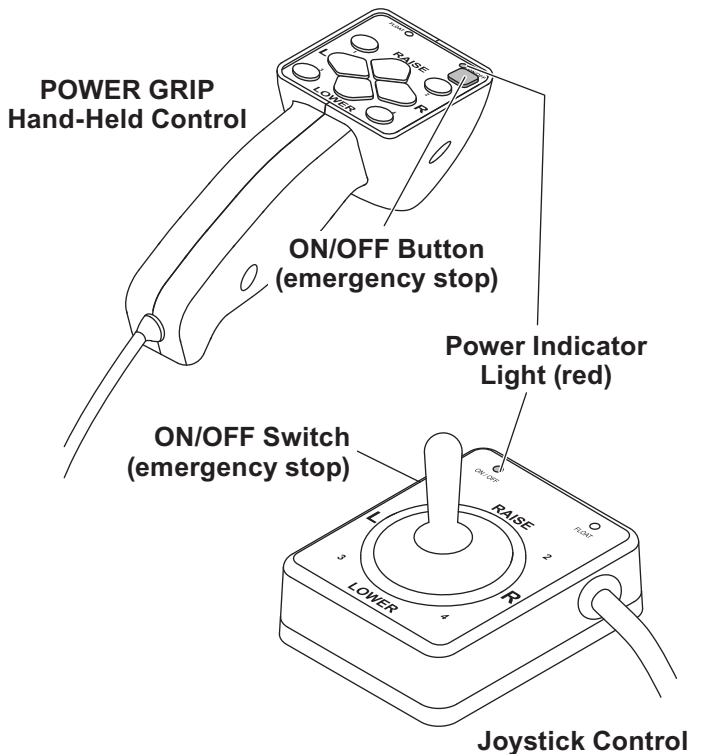

GETTING TO KNOW YOUR SNOWPLOW

FLEET FLEX ELECTRICAL SYSTEM

Your SPEEDWING™ snowplow comes standard with user-controlled programmable features. These include:

- SECURITY GUARD™ electrical anti-theft system
- Smooth stop
- One-touch FLOAT

This section provides more information about each feature as well as instructions on how to enable or disable them. These features are offered to give you the ability to secure your snowplow and customize your plowing experience.

SECURITY GUARD System

Activation & Establishing a 4-Digit Security Code

NOTE: The snowplow must be attached to the vehicle, and all the electrical connections must be connected prior to activating the security code function.

The SECURITY GUARD feature was developed as an electrical anti-theft system. The system provides a deterrent from theft and/or non-permitted use by allowing you to electronically lock the snowplow's hydraulic functions.

All multiplex snowplow controls come equipped with the SECURITY GUARD system. To use this function, you must complete the activation process.

1. Turn the vehicle ignition switch to the "ON" or "ACCESSORY" position. (It is not necessary to start the vehicle.)

2. Verify that the control power indicator is OFF. If the power indicator light is red, the control is ON. Move the ON/OFF switch to "OFF" or push the ON/OFF button to turn the control OFF.
3. To activate the SECURITY GUARD mode, move the control lever to the #1 position or press the #1 button four consecutive times, and then move the lever to the #4 position or press the #4 button four consecutive times (sequence: 1, 1, 1, 1, 4, 4, 4, 4). The green FLOAT light will flash quickly and the red power indicator light will turn ON, indicating the system is ready to accept your 4-digit security code.

Enter your 4-digit security code by moving the control lever to (or pressing the button for) any four of the eight following positions: UP, DOWN, LEFT, RIGHT, 1, 2, 3, or 4.

Once you have entered your 4-digit security code, the FLOAT light will stop flashing and the power indicator light will turn OFF. This indicates that your 4-digit security code is entered and stored in the SECURITY GUARD system.

4. Once a 4-digit security code is established and the plow/vehicle electrical connection is lost/disconnected, the SECURITY GUARD system will recognize any control that has been programmed with the same 4-digit security code. Any control not programmed with the correct 4-digit security code will require the user to enter the established security code before activating the snowplow (see the Manual Unlock procedure).

NOTE: If the control is turned ON prior to completing the programming procedure, your 4-digit security code will be cancelled.

GETTING TO KNOW YOUR SNOWPLOW

Manual Unlock

If the SECURITY GUARD™ system is activated and you are using a control set up with a different 4-digit code than the established security code, you will be required to manually enter the correct 4-digit security code before operating a locked snowplow.

1. Turn the vehicle ignition to the "ON" or "ACCESSORY" position.
2. Move the ON/OFF switch to the "ON" position or push the ON/OFF button to switch the control ON.
3. The power indicator light will flash rapidly, indicating that the snowplow is locked.
4. Enter the 4-digit security code.
5. After entering the correct security code, the power indicator light will change from flashing rapidly to a solid light to indicate that the snowplow has been successfully unlocked.

NOTE: If the plow/vehicle electrical connection is lost or disconnected, the SECURITY GUARD system will reset, requiring any control that is not programmed with the established 4-digit security code to manually re-enter the security code to activate the snowplow.

Clearing an Established 4-Digit Security Code

1. Turn the vehicle ignition switch to the "ON" or "ACCESSORY" position.
2. If the snowplow is locked (the control power indicator light will be flashing rapidly), unlock the snowplow by following the Manual Unlock procedure described above.
3. Move the ON/OFF switch to the "OFF" position or push the ON/OFF button to switch the control OFF. Verify that the power indicator light is OFF.
4. With the control OFF, move the control lever to the #2 position or press the #2 button four consecutive times, then move the lever to the #3 position or press the #3 button four

consecutive times. This sequence (2, 2, 2, 2, 3, 3, 3, 3) will clear the 4-digit security code from the SECURITY GUARD system. The FLOAT light will flash to indicate that the 4-digit security code was cleared.

NOTE: To enter a new 4-digit security code see Activation & Establishing a 4-Digit Security Code.

Light Flash Indicators

POWER – Red	Function
OFF	Control is OFF
Solid ON	Control is ON and active
Slow Flash	No communication
Fast Flash	Snowplow is locked—enter 4-digit security code to unlock

FLOAT – Green	Function
Solid ON	FLOAT function is active
Fast Flash	Security code activation in progress

Additional Notes

- The SECURITY GUARD system requires any control other than the one programmed with the assigned 4-digit security code to enter the security code before the snowplow can be activated. Once the security code is established, the SECURITY GUARD system recognizes that a control with the same security code is attached, and does not require a manual unlock to activate the snowplow. The system will recognize the control as "safe" and will automatically unlock.
- The SECURITY GUARD system is only fully functional with joystick controls PN 96555 & 96995 and hand-held controls PN 96550 & 96990.
- In the event that a snowplow is locked and cannot be manually unlocked or reset, contact your authorized dealer.
- REMINDER: Record your security code for future reference.

GETTING TO KNOW YOUR SNOWPLOW

Smooth Stop

Smooth stop, or soft stop, allows the blade to coast to a stop when the button/lever is released. The result is smoother operation, reduction in shock to the hydraulic system and an increase in hose and valve life.

While there are advantages to having this feature, there are also advantages to temporarily disabling this feature. For example, to allow for more precise movements of the blade while operating in close distances to buildings and other obstacles.

All controls come standard with this feature ENABLED. To enable/disable this feature, perform the following steps. Performing the sequence multiple times will toggle the feature between enabled and disabled.

Enable/Disable Procedure

1. Turn the vehicle ignition switch to the "ON" or "ACCESSORY" position. (It is not necessary to start the vehicle.)
2. Verify that the control power indicator is OFF. If the power indicator light is red, the control is ON. Move the ON/OFF switch to "OFF" or push the ON/OFF button to turn the control OFF.
3. Move and hold the control lever to the "R" position or press and hold the "R" button while turning the control ON. The power indicator light will turn ON and the FLOAT light will flash, indicating the status of the feature.

Light Flash Indicators

Light	Description
POWER – Red	Solid ON = Control is ON
FLOAT – Green	1 Flash = Smooth stop enabled 2 Flashes = Smooth stop disabled

One-Touch FLOAT

One-touch FLOAT immediately activates the FLOAT mode and releases the blade to the ground, without having to hold the button or lever in LOWER. This can improve transition time when backing up to plow forward again, eliminating the time spent holding the control and waiting for the blade to fully drop.

All controls come standard with this feature DISABLED. To enable/disable this feature, perform the following steps. Performing the sequence multiple times will toggle the feature between enabled and disabled.

Enable/Disable Procedure

1. Turn the vehicle ignition switch to the "ON" or "ACCESSORY" position. (It is not necessary to start the vehicle.)
2. Verify that the control power indicator is OFF. If the power indicator light is red, the control is ON. Move the ON/OFF switch to "OFF" or push the ON/OFF button to turn the control OFF.
3. Move and hold the control lever to the LOWER position or press and hold the LOWER button while turning the control ON. The power indicator light will turn ON and the FLOAT light will flash, indicating the status of the feature.

Light Flash Indicators

Light	Description
POWER – Red	Solid ON = Control is ON
FLOAT – Green	1 Flash = One-touch FLOAT disabled 2 Flashes = One-touch FLOAT enabled

ACCESSORIES & OPTIONS

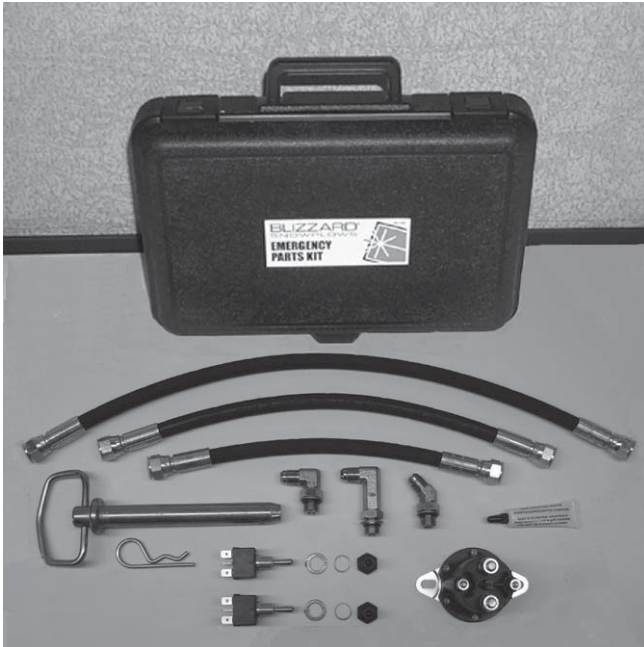

The Emergency Parts Kit (PN 40589) includes the most common replacement parts: angle ram hose, lift ram hoses, hitch pin w/hairpin cotter, one of each type of hose fitting, POWER HITCH™ toggle switches, 0.25 oz dielectric grease, and 1 quart BLIZZARD® hydraulic fluid. The compact and durable plastic case (13.5" x 9" x 3.3") allows for easy storage behind or under your seat.

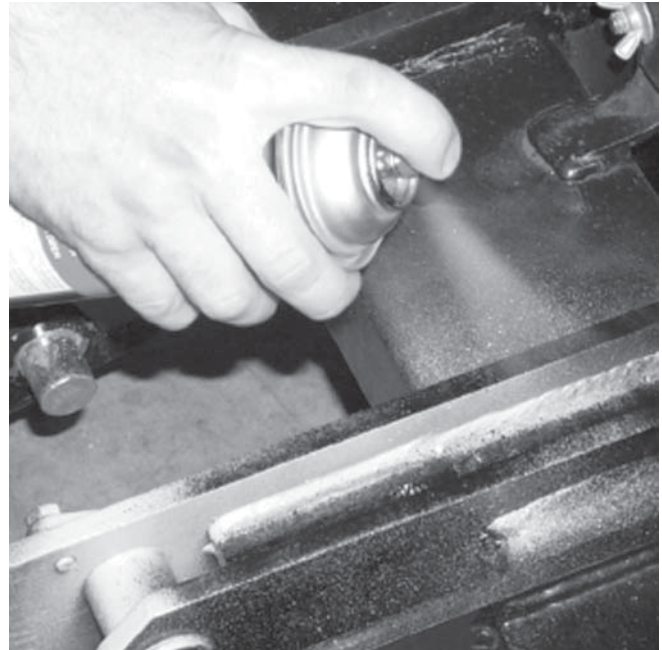

Putting your snowplow away for the winter? Have a deep scratch to cover? Clean up your blade and snowplow parts with our gloss spray paints. BLIZZARD touch-up paint provides an excellent finish to help keep your snowplow looking its best. Paint provided in 12-oz spray cans.



BLIZZARD hydraulic fluid is specially formulated for use in BLIZZARD snowplows and can significantly enhance the operation and performance of the hydraulic system. BLIZZARD zinc-free hydraulic fluid maintains its viscosity to temperatures as low as -40°F (-40°C). BLIZZARD hydraulic fluid is available by the quart, gallon, case, or 55-gallon drum.

ACCESSORIES & OPTIONS

Ballast (additional weight) is an important part of qualifying vehicles for snowplow eligibility. Rear ballast must be used when necessary to remain in compliance with axle ratings and ratios as specified by the vehicle manufacturer. If ballast is required, it is important that it be secured properly behind the rear axle. A Ballast Retainer Kit is available from your BLIZZARD® outlet, PN 62849.

NOTE: The ballast retainer kit is for snowplow vehicles requiring ballast. See your BLIZZARD outlet for the correct amount of ballast required. Include the weight of the retainer as part of the ballast requirement. Sandbags are recommended for use as ballast.

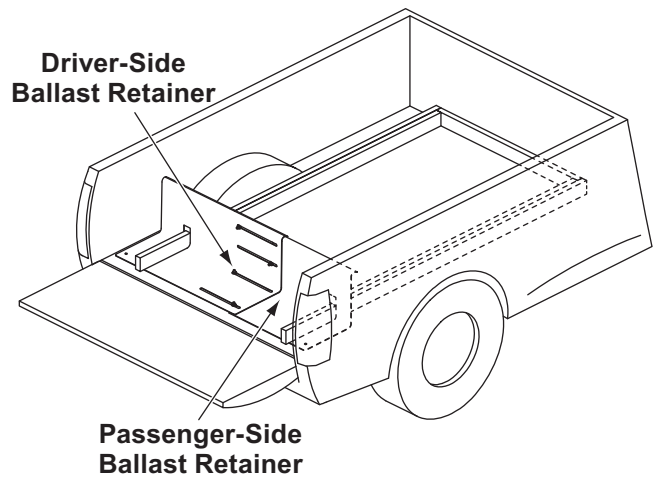

MOUNTING SNOWPLOW TO VEHICLE

MOUNTING SNOWPLOW (ON)

⚠ WARNING

Keep 8' clear of the blade when it is being raised, lowered, or angled. Do not stand between vehicle and blade or directly in front of the blade. If the blade hits or drops on you, you could be seriously injured.

⚠ WARNING

Inspect snowplow components and fasteners for wear or damage whenever mounting or removing the snowplow. Worn or damaged components could allow the snowplow to drop unexpectedly.

NOTE: Use dielectric grease to prevent corrosion on all connections.

1. Slowly drive the vehicle forward to engage the mount adapter into the A-frame.
2. Move the power switch to the center, or "OFF," position.
3. Plug in the electrical harnesses.

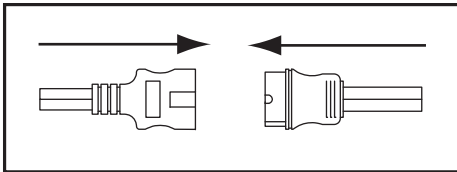

4. Push and hold power switch RIGHT, and push UP and hold Arm/Blade Operation switch. The arm will engage the mount adapter and pull the snowplow toward the vehicle.

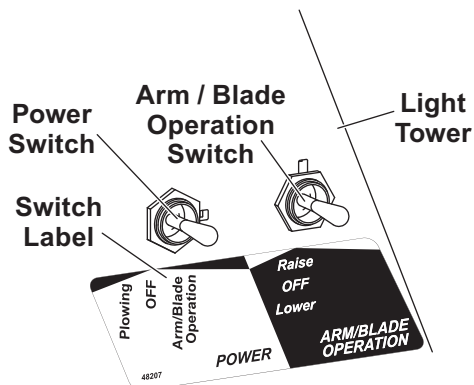

5. Rotate and release the hitch pin. The hitch pin is fully engaged when the pin handle is against the pin guide plate.

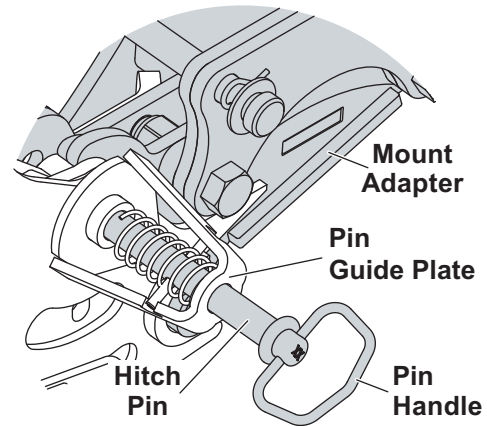

6. Repeat Step 5 on the passenger's side.

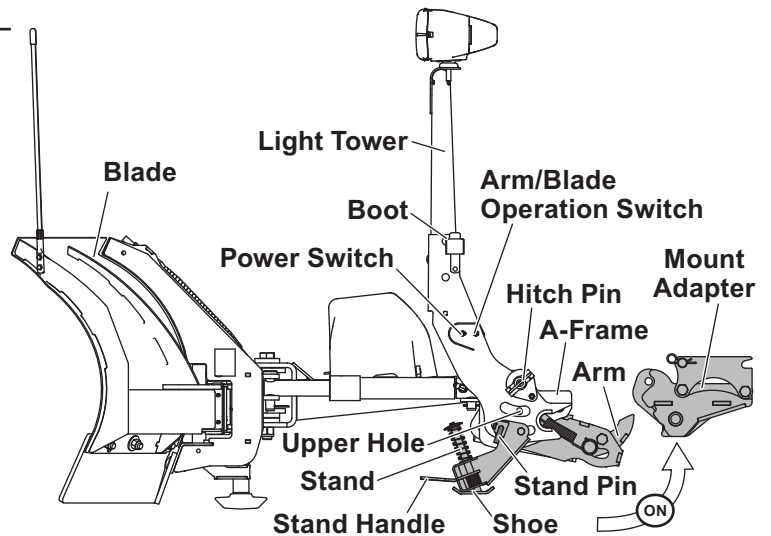

7. While holding the power switch RIGHT, push DOWN and hold the Arm/Blade Operation switch. The arm will disengage the mount adapter to relieve tension on the stand.
8. Pull the stand handle up. The stand will lift off the ground. Pull the stand pin out. Rotate the stand up until the stand pin seats into the upper hole on the A-frame. The pin must lock into the upper A-frame hole.
9. Repeat Step 8 on the passenger's side.
10. Move the power switch to the left, or "PLOWING," position.

OPERATING YOUR SNOWPLOW

SPEEDWING™ BLADE JOYSTICK SOLENOID CONTROL

⚠ WARNING

To prevent accidental movement of the blade, always move the ON/OFF switch to OFF whenever the snowplow is not in use. The power indicator light will turn OFF.

⚠ CAUTION

DO NOT hold control lever in RAISE, ANGLE LEFT, or ANGLE RIGHT position after blade has reached desired position. To do so will use excess current and overheat components.

1. Turn the vehicle ignition switch to the "ON" or "ACCESSORY" position.
2. Move the control ON/OFF switch to the "ON" position. The power indicator light glows red, indicating the control is ON. The power indicator light glows red whenever the control and the vehicle ignition switch are both ON, the electrical connections to the snowplow are completed and the power switch on the light tower is in the "PLOWING" position. If the power switch is in the "OFF" position, the power indicator light will flash.

The ON/OFF switch operates as an emergency stop, if required.

Function Time-Outs

All control functions, except LOWER/FLOAT, time out (stop) automatically after a period of time. This is to limit the amount of electrical energy required from the vehicle.

NOTE: If control function times out before desired blade movement is complete, release the lever to the center position, then move back into the desired function.

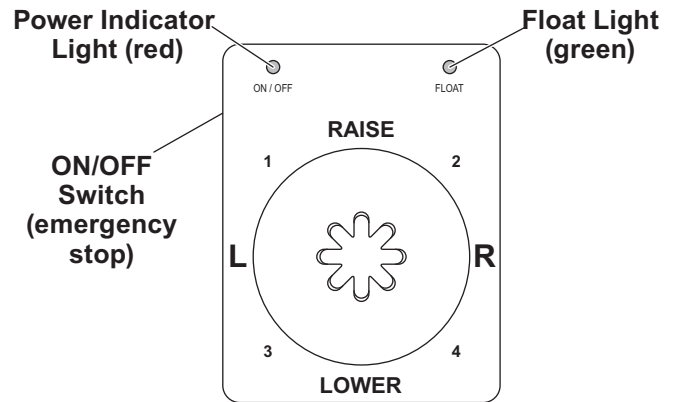

Automatic Shutdown

The control will automatically turn OFF after being idle for 20 minutes. To reactivate the control after a shutdown, move the ON/OFF switch to OFF, then back to ON.

Smooth Stop

The control automatically allows the blade to coast to a stop when the lever returns to center position. This results in smoother operation, reduces the shock to the hydraulic system, and increases hose and valve life.

OPERATING YOUR SNOWPLOW

Control Lever Movement

From the center position, the control lever can be moved in one of eight directions to control various movements of the snowplow blade. To change from one movement of the blade to another, the control lever must be moved back to the center position before selecting the desired function. Whenever the lever is released, it should spring back into the center position to stop any blade movement.

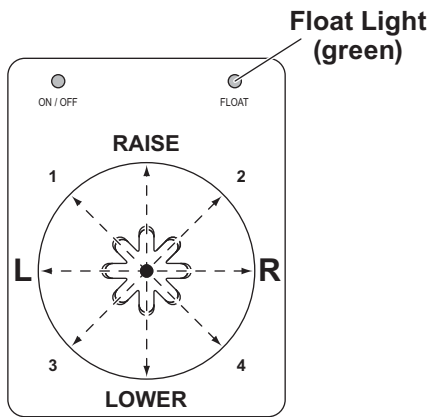

Control Functions

Raise, Lower, Float, Angle

Moving the control lever straight up and down or from side to side on the control body will result in the blade movements described in the following table.

NOTE: If control function times out before desired blade movement is complete, release the lever to the center position, then move back into the desired function.

Function	Description of Operation
ON/OFF	Move the control power switch to ON to activate the hydraulic system. Turn the control OFF to lock the blade in place. This prevents accidental movement of the blade.
RAISE	Move control lever toward top of control body to raise snowplow and cancel FLOAT mode. Function times out after 3.5 seconds.
LOWER	Move control lever toward bottom of control body to lower snowplow. Release lever to stop blade at desired height.
FLOAT	Move control lever to LOWER position and hold for 3/4 second to activate this mode. FLOAT light in upper right corner of control face will illuminate. Blade will lower to ground surface and follow contour of surface as it dips or raises. Function does not time out; however, control will shut down after 20 minutes of nonuse. Move lever to RAISE position momentarily to cancel FLOAT. FLOAT will continue during Angle Left and Angle Right functions if not interrupted by Raise function.
L (Angle Left)	Move the control lever left to angle the blade left. Function times out after 3.5 seconds.
R (Angle Right)	Move the control lever right to angle the blade right. Function times out after 3.5 seconds.

OPERATING YOUR SNOWPLOW

SPEEDWING™ BLADE POWER GRIP™ HAND-HELD CONTROL

⚠ WARNING

To prevent accidental movement of the blade, always push the ON/OFF button to switch the control OFF whenever the snowplow is not in use. The power indicator light will turn OFF.

1. Turn the vehicle ignition switch to the "ON" or "ACCESSORY" position.
2. Press the ON/OFF button on the control. The power indicator light glows red, indicating the control is ON. The power indicator light glows red whenever the control ON/OFF switch and the vehicle ignition switch are both ON, the electrical connections to the snowplow are completed and the power switch on the light tower is in the "PLOWING" position. If the power switch is in the "OFF" position, the power indicator light will flash.

The ON/OFF button operates as an emergency stop, if required.

Function Time-Outs

All control functions, except LOWER/FLOAT, automatically time out (stop) after a period of time. This helps prevent unnecessary battery drain.

NOTE: If control function times out before desired blade movement is complete, release button and press again.

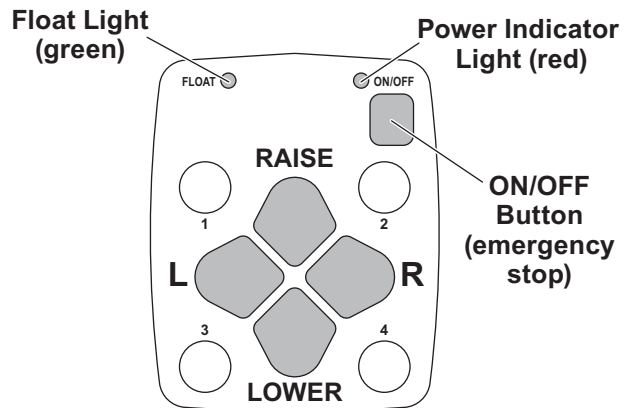

Automatic Shutdown

The control automatically turns OFF after being idle for 20 minutes.

Smooth Stop

The control automatically allows the blade to coast to a stop. This results in smoother operation, reduces the shock to the hydraulic system, and increases hose and valve life.

Control Functions

Raise, Lower, Float, Angle

The four diamond-shaped buttons in the center of the control face, when pressed, will result in the blade movements described in the table.

Function	Description of Operation
ON/OFF	Press this button to turn the control ON and OFF. Turn the control OFF (power indicator light OFF) to lock the blade in place. This prevents accidental movement of the blade.
RAISE	Press this button to raise snowplow and cancel FLOAT mode. Function times out after 3.5 seconds.
LOWER	Press this button to lower snowplow. Release button to stop blade at desired height.
FLOAT	Press LOWER button and hold for 3/4 second to activate this mode. FLOAT light in upper left corner of control face will illuminate. Blade will lower to ground surface and follow contour of surface as it dips or raises. Function does not time out; however, control will shut down after 20 minutes of nonuse. Press RAISE button momentarily to cancel FLOAT. FLOAT will continue during Angle Left and Angle Right functions if not interrupted by Raise function.
L (Angle Left)	Press this button to angle left position. Function times out after 3.5 seconds.
R (Angle Right)	Press this button to angle right position. Function times out after 3.5 seconds.

OPERATING YOUR SNOWPLOW

PLOWING POSITIONS

Your SPEEDWING™ snowplow is the newest multi-position snowplow on the market. The easy-to-use controls allow you to automatically adjust the snowplow blade into an infinite number of plowing positions. Review the following text and illustrations for instruction on maneuvering your snowplow.

A. Lowered or Floating

Pulling the joystick back, toward LOWER, or pushing the LOWER button on the hand-held control, will lower your blade to the ground. Pushing and holding the control in this position for 3/4 second will activate the FLOAT mode, causing the blade to lower to ground surface and follow contour of surface as it dips or raises.

B. Raised

Pushing the joystick forward, toward RAISE, or pushing the RAISE button on the hand-held control, will lift your blade off the ground. To stop raising the snowplow, simply return the joystick to the center position or release the control button. The snowplow has reached its maximum raised position when the blade stops lifting.

C. Angled Right

To angle your blade to the right, move the control lever toward "R" or push the "R" button on the hand-held control. To stop angling the snowplow, simply return the joystick to the center position or release the control button. The snowplow has reached its maximum angled position when the blade stops moving to the right side.

D. Angled Left

To angle your blade to the left, move the control lever toward "L" or push the "L" button on the hand-held control. To stop angling the snowplow, simply return the joystick to the center position or release the control button. The snowplow has reached its maximum angled position when the blade stops moving to the left side.

NOTE: To prevent premature failure of the power contactor (solenoid), return the joystick to its neutral (center) position, or release the hand-held control button, immediately after the blade reaches the limit of any position. Continuing to hold the control after the blade has reached the limit of movement in any position will reduce the life of the solenoid.

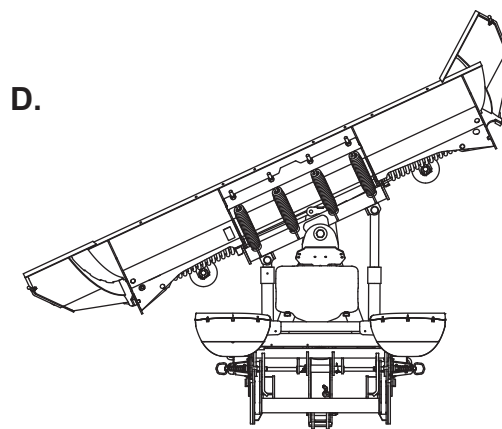
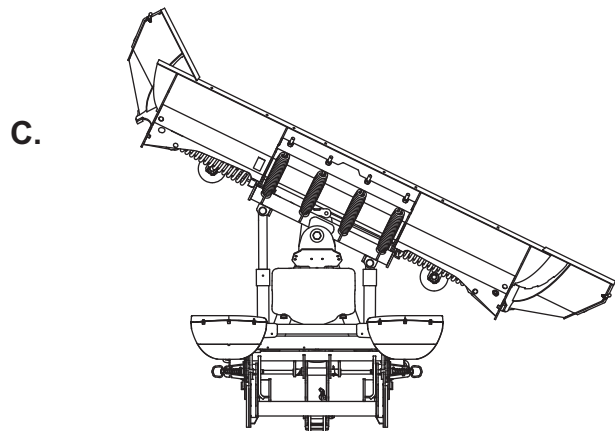
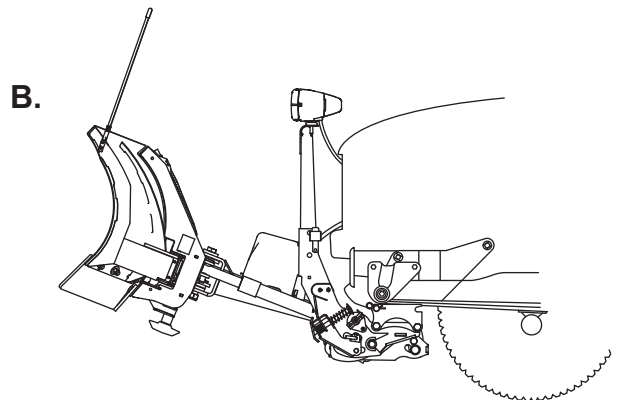
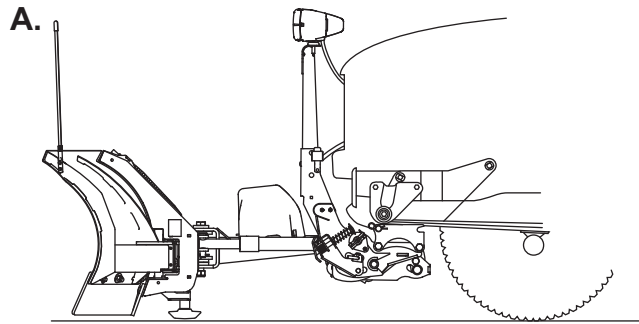

OPERATING YOUR SNOWPLOW

E. Straight Scoop

Angle the blade left or right to move it to the straight-across position. Both wings move to the scoop position.

F. Straight Blade Option

The snowplow wings may be pinned in position to operate as a straight blade using the hardware provided.

⚠ WARNING

Keep 8' clear of the blade when it is being raised, lowered, or angled. Do not stand between vehicle and blade or directly in front of the blade. If the blade hits or drops on you, you could be seriously injured.

⚠ WARNING

To prevent accidental movement of the blade, always turn the control OFF whenever the snowplow is not in use. The power indicator light will turn OFF.

1. Fully angle the blade to one side. Lower the blade and turn the plow control and vehicle ignition OFF.
2. Standing behind the blade, install a 3/4" x 9" clevis pin down through the holes in the back of the blade assembly, as shown.
3. Secure the pin with a 1/8" hairpin cotter.
4. Repeat Steps 1–3 on the opposite side.
5. To remove the clevis pins, reverse the above procedure.

E.

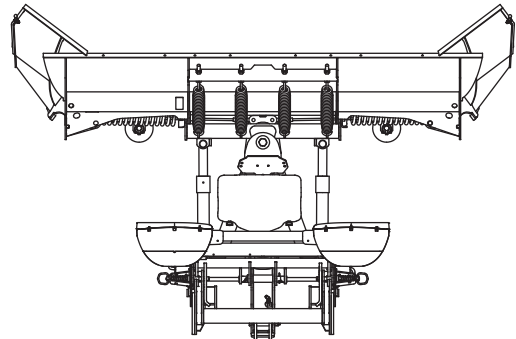

F.

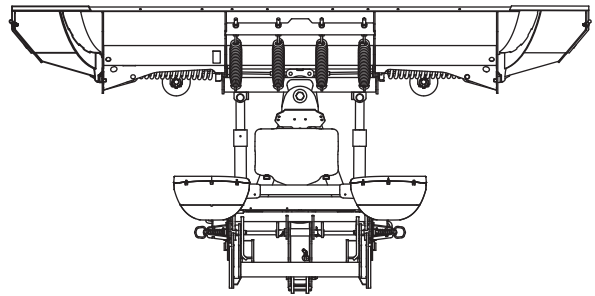

3/4" x 9" Clevis Pin

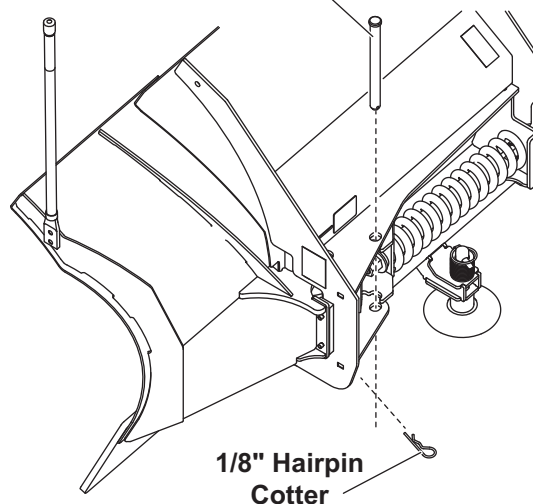

1/8" Hairpin Cotter

OPERATING YOUR SNOWPLOW

SNOWPLOW HEADLAMP CHECK

With all electrical plugs connected, check the operation of vehicle and snowplow headlamps.

Connecting and disconnecting the electrical plugs should switch between the vehicle and snowplow headlamps as follows:

- Electrical plugs **DISCONNECTED**—Vehicle headlamps function normally.
- Electrical plugs **CONNECTED**—Vehicle headlamp functions transfer to the snowplow headlamps. On some Daytime Running Lamp (DRL) systems, both the vehicle and snowplow headlamps will function.

Aiming the Headlamps

- Aim the snowplow headlamps with the snowplow mounted and raised in the transport position. See "Aiming Headlamp Beams" in the Maintenance section for instructions.
- Aim the vehicle headlamps with the snowplow removed from the vehicle.

Lights	Results
Parking Lamps	Both vehicle and snowplow lamps should be ON.
Right Turn Signal	Both vehicle and snowplow lamps should be ON.
Left Turn Signal	Both vehicle and snowplow lamps should be ON.

OPERATING YOUR SNOWPLOW

DISC SHOE ADJUSTMENT

⚠ WARNING

Blade can drop unexpectedly. Place blade on stand assembly. Failure to do so could result in serious personal injury.

Recommended Shoe Adjustments

For gravel surfaces: The bottom surface of the shoe should be 1/4" to 1/2" below the cutting edge.

For hard surfaces (concrete or asphalt): The bottom surface of the shoe should be even with the cutting edge.

1. Raise the blade one foot off the road surface, turn the control OFF, and from in front of the blade, place stand assembly or sturdy blocking under the cutting edge.
2. Turn the control ON and lower the blade onto the stand assembly or blocking. Turn the control and vehicle ignition OFF.
3. Remove the linchpin and slide the disc shoe down and out of the shoe holder.
4. Remove one or more washers from the shoe stem, and reinstall the shoe into the shoe holder.

5. Place the removed washers onto the shoe stem above the shoe holder.

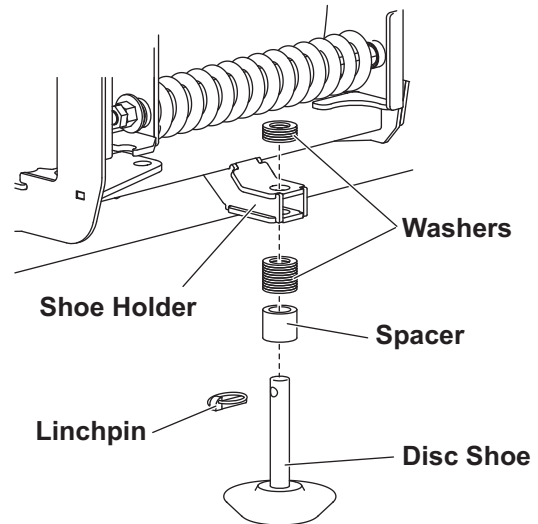

6. Reinstall the linchpin.
7. Turn the vehicle ignition to the "ON" position, and turn the control ON. Raise the blade slightly from the stand assembly or blocking. Turn the control OFF, and remove the stand assembly or blocking.
8. Stand 8 feet clear of the blade when checking the height adjustment of the cutting edge to the road surface.

OPERATING YOUR SNOWPLOW

HYDRAULIC SYSTEM

The hydraulic unit's valve manifold includes relief valves to prevent damage to the blade or vehicle if either end of the blade hits an obstacle. The valves are preset and nonadjustable. When force against the blade causes the pressure in an extended ram to exceed the set limits, the relief valve opens, allowing fluid to escape, and the ram retracts.

For hydraulic fluid type and filling instructions, see "Hydraulic System, Annual Fluid Change" in the Maintenance section of this manual.

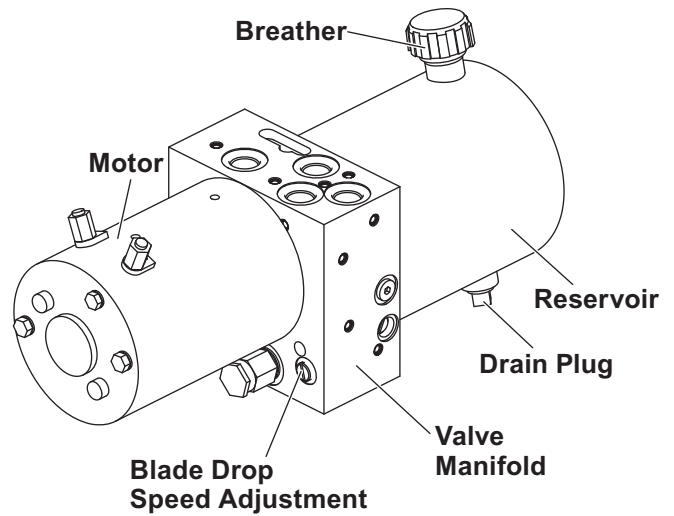

Some components not shown.

Hose Ports

- Lift Ram, Rod End
- Lift Ram, Base End
- DS Angle Ram
- PS Angle Ram
- Drop Speed Adjustment (CW = Slower)
- Pressure Test Port SAE -4 ORB

Solenoid Valve	S1	S2	S3
Valve Model	SV08-22	SV08-47E	SV08-47C
Harness "C" Coil		S2-C1	S3-C1
Harness "B" Coil	S1	S2-C2	S3-C2

Plow Function	Active Coil	Active Port
Raise or Hitch	S2-C1	Lift Ram, Base End
Lower/Float	S1	Lift Ram, Base End
Angle Right	S3-C2	DS Angle Ram
Angle Left	S3-C1	PS Angle Ram
Unhitch	S2-C2 & S1	Lift Ram, Rod End

Torque Specifications

All Solenoid/Check Valves:	19–21 ft-lb
All Solenoid Coil Nuts:	48–60 in-lb
Motor Relay Terminals:	Small 10–15 in-lb
Motor Terminals:	Large 25–35 in-lb
	50–60 in-lb

48421

Hydraulic Information Label
(Located inside hydraulic unit cover.)

OPERATING YOUR SNOWPLOW

BLADE DROP SPEED ADJUSTMENT

⚠ WARNING

Keep 8' clear of the blade when it is being raised, lowered, or angled. Do not stand between vehicle and blade or directly in front of the blade. If the blade hits or drops on you, you could be seriously injured.

1. The blade drop speed may be adjusted by turning the needle valve.

NOTE: The blade will not drop when drop speed needle valve is fully tightened (clockwise). Turn OFF the plow control, turn the needle valve 1/8 turn outward (counterclockwise), then proceed with blade drop speed adjustment.

2. Lower the blade to the ground before making adjustment.
3. Turn the needle valve inward (clockwise) to decrease the drop speed. Turn the needle valve outward (counterclockwise) to increase the drop speed.
4. Stand 8 feet clear of the blade when checking adjustment.

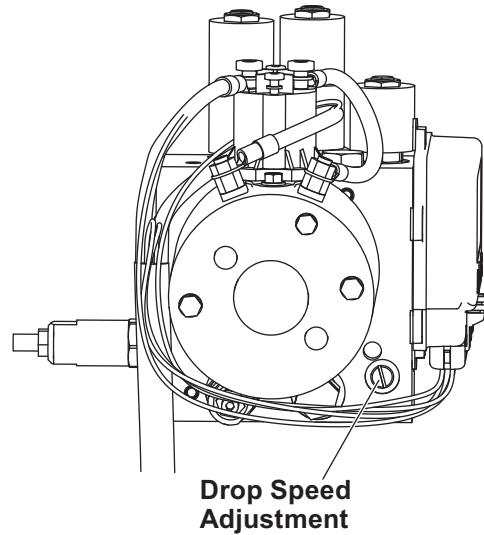

OPERATING YOUR SNOWPLOW

TRANSPORTING THE SNOWPLOW

⚠ WARNING

Position the blade so it does not block headlamp beams. Do not change blade position while traveling. You could suddenly lower the blade accidentally.

⚠ CAUTION

Transport speed should not exceed 45 mph (72 km/h). Further reduce speed under adverse travel conditions.

These instructions are for driving short distances to and from plowing jobs. Remove the snowplow from the vehicle for long trips and place in pickup box, following recommended mechanical lifting cautions and procedures.

1. Fully raise the blade.
2. Adjust the blade height for maximum snowplow headlamp illumination.
3. Adjust the blade to the straight position.
4. Turn the control OFF to lock the blade in place.

NOTE: Overheating is unlikely under normal driving conditions, but occasionally the snowplow may be positioned where it deflects air away from the radiator. If this occurs, stop the vehicle and raise, lower, or angle the snowplow slightly to correct the overheating.

NOTE: Only the driver should be in the vehicle cab when the snowplow is attached.

Pinning the Blade in Raised Position

The snowplow may be pinned in the raised position for transport using the hardware provided.

1. Fully raise the blade.
2. Assemble the 3/4" washer onto the 3/4" x 6" clevis pin.
3. Install the pin through the tube in the mount adapter and through the hole in the A-frame plate as shown.
4. Secure the pin with a 1/8" hairpin cotter.
5. To remove the clevis pin after transport, reverse the above steps.

Blade in raised position

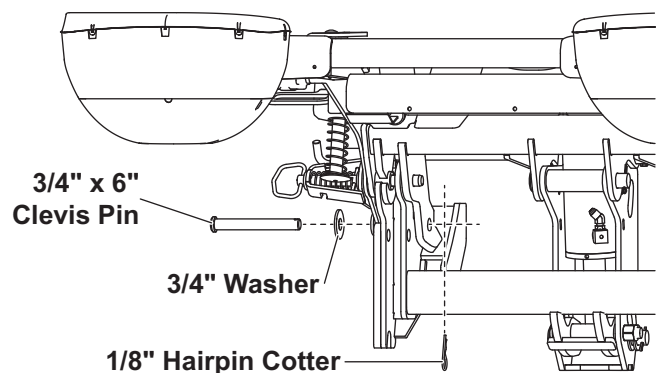
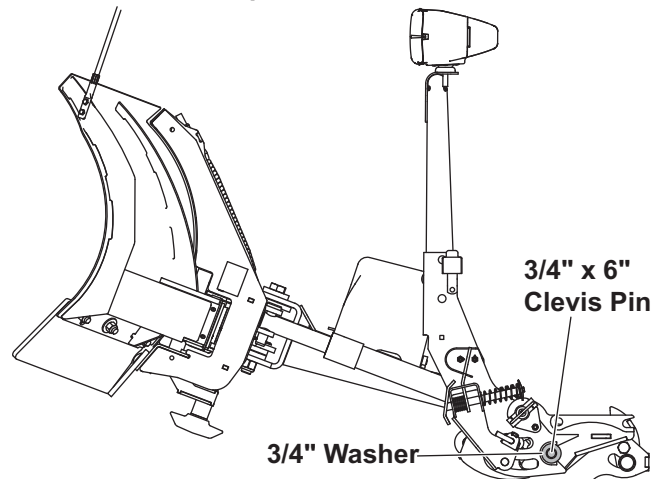

OPERATING YOUR SNOWPLOW

DRIVING AND PLOWING ON SNOW AND ICE

⚠ WARNING

Drinking then driving or plowing is very dangerous. Your reflexes, perceptions, attentiveness, and judgment can be affected by even a small amount of alcohol. You can have a serious or even fatal collision if you drive after drinking. Please do not drink and then drive or plow.

Refer to vehicle owner's manual instructions for driving in snow and ice conditions. Remember, when you drive on snow or ice, your wheels will not get good traction. You cannot accelerate as quickly, turning is more difficult, and you will need longer braking distance.

Wet and hard-packed snow or ice offers the worst tire traction. It is very easy to lose control. You will have difficulty accelerating. If you do get moving, you may have poor steering and difficult braking, which can cause you to slide out of control.

Here are some tips for driving in these conditions:

- Drive defensively.
- Do not drink, then drive or plow snow.
- Plow or drive only when you have good visibility for operating a vehicle.
- If you cannot see well due to snow or icy conditions, you will need to slow down and keep more space between you and other vehicles.
- Slow down, especially on higher-speed roads. Your headlamps can light up only so much road ahead.
- If you are tired, pull off in a safe place and rest.
- Keep your windshield and all glass on your vehicle clean to see around you.
- Dress properly for the weather. Wear layers of clothing; as you get warm, you can take off layers.

PLOWING SNOW

⚠ WARNING

Never plow snow with head out the vehicle window. Sudden stops or protruding objects could cause personal injury.

⚠ CAUTION

Wear a seat belt when plowing snow. Hidden obstructions could cause the vehicle to stop suddenly, resulting in personal injury.

⚠ CAUTION

Flag any obstructions that are hard to locate under snow to prevent damage to product or property.

⚠ CAUTION

Never stack snow with the blade angled. This could damage the snowplow or the vehicle bumper.

⚠ CAUTION

Plowing speed should not exceed 10 mph (16 km/h).

NOTE: Only the driver should be in the vehicle cab when the snowplow is attached.

General Instructions

1. Before plowing, make sure that you know of any obstructions hidden beneath the snow, such as bumper stops in parking lots, curbs, sidewalk edges, shrubs, fences, or pipes sticking up from the ground. If unfamiliar with the area to be plowed, have someone familiar with the area point out obstacles.
2. If possible and you have good visibility, plow during the storm rather than letting snow accumulate.
3. Do not exceed 10 mph (16 km/h) when plowing snow.
4. When you are stacking snow, begin raising the blade as you come close to the stack. This will let the blade ride up the stack.

OPERATING YOUR SNOWPLOW

Hard-Packed Snow

1. Raise the disc shoes so that the cutting edge comes into direct contact with the pavement.
2. Use lowest gear to place maximum power behind cutting edge.
3. An angled blade is more effective for removing hard-packed snow.

Deep Snow

1. For straight blades, shear off top layers by plowing with the blade raised 3 to 4 inches for the first pass.
2. Bite into the edges using only partial blade width until the job is cut down to size for full-blade plowing.

Rule of thumb:

- 6" of snow — plow with entire blade width
- 9" of snow — plow with 3/4 blade width
- 12" of snow — plow with 1/2 of the blade

Experience and "feel" are the best guides.

3. When plowing deep snow, be sure to keep the vehicle moving.
4. Ballast is suggested for maximum traction. Secure ballast behind the rear wheels. Do not exceed vehicle's GVWR and GAWR.
5. For increased traction, use tire chains where legal.

Clearing Driveways

1. Head into the driveway with the blade angled and plow the snow away from any buildings. Widen driveway by rolling snow away from any buildings.
2. If a building is at the end of the driveway, plow to within a vehicle length of the building. Push as much snow as possible off the driveway.
3. With a raised blade, drive through remaining snow to building. Drop blade and back drag snow away from the building at least one vehicle length. Repeat if necessary.

4. Back the vehicle to the building and plow forward, removing the remaining snow from the driveway. Check municipal ordinances for proper disposal of snow.

Clearing Parking Lots

1. Clear areas in front of buildings first. With the blade raised, drive up to the building. Drop the blade and back drag the snow away from building. When snow is clear of the buildings, turn the vehicle around and push snow away from the buildings toward the outer edges of the lot.
2. Plow a single path down the center in the lengthwise direction.
3. With the blade in the angle position, plow successive strips lengthwise until the area is cleared and snow is stacked around the outer edges.
4. If snow is too deep to clear in the above manner, clear the main traffic lanes as much as possible. Check municipal ordinances for proper disposal of snow.

PARKING WITH SNOWPLOW ATTACHED

Whenever you park your vehicle, completely lower the blade to the ground.

WARNING

Lower the blade when the vehicle is parked. Keep 8' clear of the blade. Temperature changes could change hydraulic pressure, causing the blade to drop unexpectedly or damaging hydraulic components. Failure to do this could result in serious personal injury.

TOWING A DISABLED OR STUCK VEHICLE

Do not use any snowplow components as an attaching point when retrieving, towing, or winching a disabled or stuck vehicle.

REMOVING SNOWPLOW FROM VEHICLE & STORAGE

REMOVING SNOWPLOW (OFF)

⚠ WARNING

Keep 8' clear of the blade when it is being raised, lowered, or angled. Do not stand between vehicle and blade or directly in front of the blade. If the blade hits or drops on you, you could be seriously injured.

⚠ WARNING

Inspect snowplow components and fasteners for wear or damage whenever mounting or removing the snowplow. Worn or damaged components could allow the snowplow to drop unexpectedly.

During the off-season, the control can be removed. Disconnect the connector in the cab and store the control in the glove box of the vehicle.

1. Lower the snowplow to the ground with the blade straight. Turn the plow control in the cab OFF.
2. Move the power switch to the center, or "OFF," position.

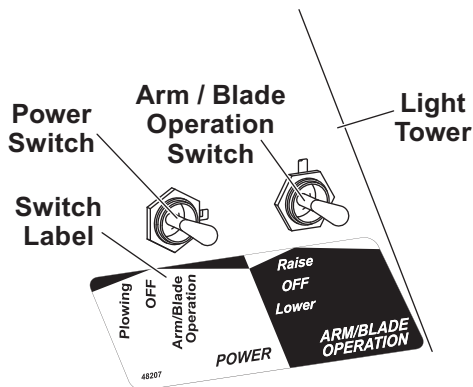

3. While holding the power switch RIGHT, push DOWN and hold the Arm/Blade Operation switch. The arm will disengage the mount adapter to relieve tension on the stand.

4. Pull the stand pin out. Rotate the stand down until the stand pin seats into the lower A-frame hole. The stand pin must lock into the lower A-frame hole. Push down on the top of the shoe. The shoe will be on the ground.

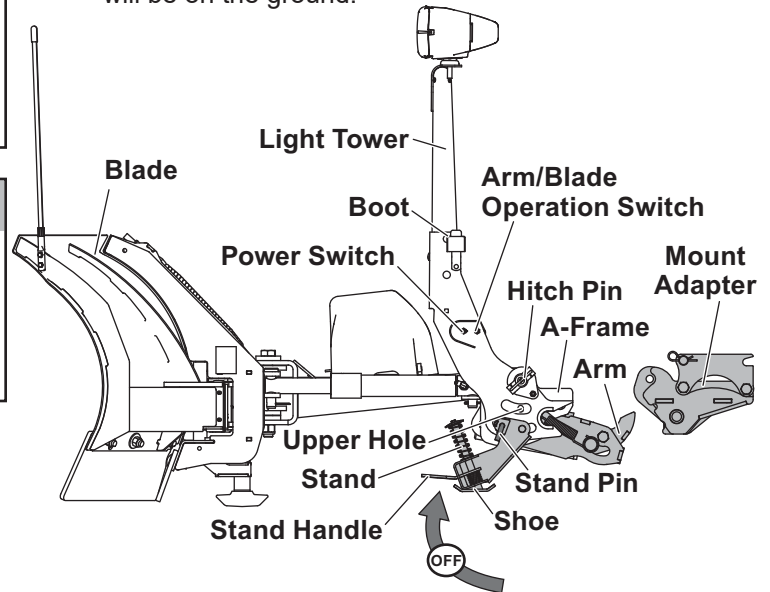

5. Repeat Step 4 on the passenger's side.
6. Push and hold the power switch RIGHT and push UP the Arm/Blade Operation switch. The arm will engage the mount adapter and pull the snowplow tightly to the vehicle.
7. Rotate and pull the hitch pin. Rotate the hitch pin into the retracted position.

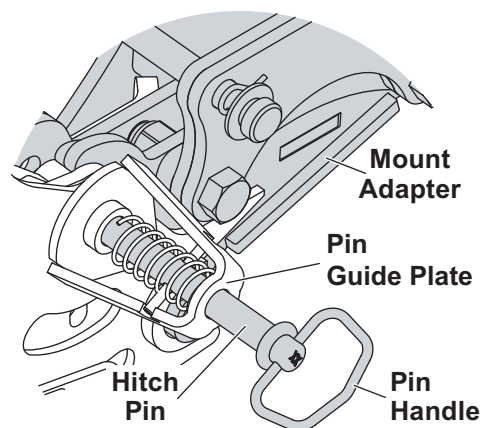

8. Repeat Step 7 on the passenger's side.

REMOVING SNOWPLOW FROM VEHICLE & STORAGE

9. While holding the power switch RIGHT, push DOWN and hold the Arm/Blade Operation switch to fully lower the arm.

⚠ CAUTION

On 2-plug electrical systems, plug covers shall be used whenever snowplow is disconnected. Vehicle battery cable is 12V unfused source.

10. Unplug the electrical harnesses.

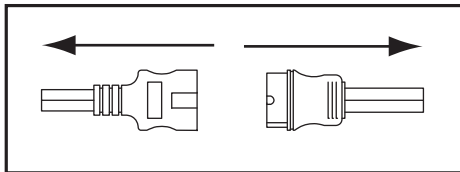

NOTE: After each use of the snowplow, reapply dielectric grease to the electrical plugs to maintain the protective coating on the terminals.

11. Place the electrical plugs in storage position. The plugs are equipped with plug covers.

MAINTENANCE

AIMING HEADLAMP BEAMS

Tighten headlamp fasteners to 45 ft-lb once correct visual aim is achieved.

1. Park the vehicle on a level surface 25 feet in front of a matte-white screen, such as a garage door. The screen should be perpendicular both to the ground and to the vehicle centerline.
 2. The vehicle should be equipped for normal operation. The snowplow blade should be in place and in raised position. Below are steps listed by the Society of Automotive Engineers (SAE) pertinent to headlamp aiming in specification #SAE J599d.
 3. Prepare vehicle for headlamp aim or inspection. Before checking beam aim, the inspector will:
 - a. Remove ice or mud from under fenders.
 - b. Set tire inflation pressures to the values specified on vehicle information label.
 - c. Check springs for sag or broken leaves.
 - d. See that there is no load in the vehicle other than the driver and ballast as specified in the Power Match selection system.
 - e. Check the functioning of any automatic vehicle leveling systems and specific manufacturer's instructions pertaining to vehicle preparation for headlamp aiming.
 - f. Clean the headlamp lenses.
 - g. Check for bulb burnout and proper beam switching.
 - h. Stabilize the suspension by rocking the vehicle sideways.
4. Mark (or tape) the vertical centerline of the snowplow headlamps and the vertical centerline of the vehicle on the screen. Mark the horizontal centerline of the snowplow headlamps on the screen (distance from ground to snowplow headlamp centers).
 5. Align the top edge of the high-intensity zone of the snowplow lower beam below the horizontal centerline and the left edge of the high-intensity zone on the vertical centerline for each snowplow headlamp. (Refer to diagram below.)

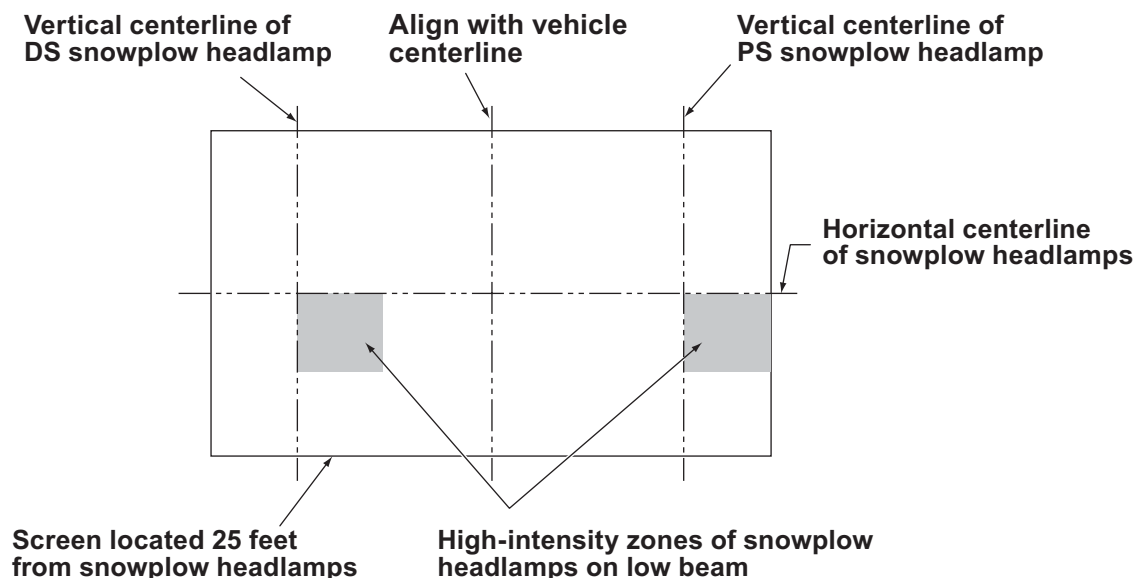

MAINTENANCE

PRESEASON CHECK

WARNING

Lower the blade when the vehicle is parked. Keep 8' clear of the blade. Temperature changes could change hydraulic pressure, causing the blade to drop unexpectedly or damaging hydraulic components. Failure to do this could result in serious personal injury.

Before the snow season, check your equipment to make sure that it is in working condition. Here are some tips for getting your equipment ready:

- Clean and tighten all electrical connections and coat with dielectric grease to prevent corrosion.
- Check the hydraulic system for leaks and cracked or damaged hoses.
- Drain the hydraulic system and refill with recommended hydraulic fluid. For hydraulic fluid type and filling instructions, see "Hydraulic System, Annual Fluid Change" in this section of the manual.
- Replace worn or damaged parts.
- Check all mounting points and tighten fasteners on both snowplow and vehicle. Verify that all cotter pins are in place.
- Repaint blade assembly and attachments, as necessary, to protect the metal.
- Install auxiliary and flashing lights for compliance and visibility in accordance with local regulations.
- Check headlamps, auxiliary lights, heater, and windshield wipers for proper operation.
- Inspect and test your battery. Recharge or replace as necessary.
- Ballast may be necessary, or beneficial, on some vehicles to provide maximum traction, braking, and handling.
- Any ballast material (such as sand or blocks) must be solidly secured to the vehicle to prevent it from moving under harsh plowing conditions.

POSTSEASON MAINTENANCE

NOTE: Coat all electrical connections with dielectric grease.

- Clean and paint the blade and components as needed.
- Apply general purpose petroleum grease to exposed chrome surfaces of the rams to prevent rust.
- Lubricate the hitch pins with general purpose petroleum grease.
- Grease the fittings on the blade wing hinges.

MAINTENANCE

MAINTENANCE AND ADJUSTMENT

⚠ WARNING

Lower the blade when the vehicle is parked. Keep 8' clear of the blade. Temperature changes could change hydraulic pressure, causing the blade to drop unexpectedly or damaging hydraulic components. Failure to do this could result in serious personal injury.

Your BLIZZARD® snowplow is designed for rugged, dependable service. However, like the vehicle on which it is mounted, it needs regular care and maintenance.

Check the following before and frequently during the plowing season:

1. Make sure that all fasteners, mounting bolts, and hydraulic connections are tight. Pay particular attention to mount adapter fasteners and the 1" pivot bolt.
2. Make sure that all electrical connections, including grounds, are clean, tight, free of rust or corrosion, and are coated with dielectric grease.
3. Check all plugs and seals for hydraulic fluid leaks. Repair as necessary.

⚠ CAUTION

Overtightening springs will not increase blade trip force and can damage the springs.

4. **Trip Spring Adjustment:** To adjust trip spring tension, adjust the eyebolts located at the top of the blade. Tighten the adjusting nut until the coils begin to separate. When tension is properly adjusted, a sheet of paper should pass between the second and third coils. When the proper tension is reached, tighten the locknut.
5. **Blade Finish:** If the powder-coat finish is nicked or scratched, repair the surface and paint with BLIZZARD white or black paint (available in aerosol or quart cans).

MAINTENANCE

HYDRAULIC SYSTEM

Fluid Level

⚠ CAUTION

Do not mix different kinds of hydraulic fluid. Some fluids are not compatible and may cause performance problems and product damage.

NOTE: Remove the breather slowly to relieve any pressure in the reservoir.

1. With the snowplow attached to the vehicle and the blade on the ground, turn control OFF.

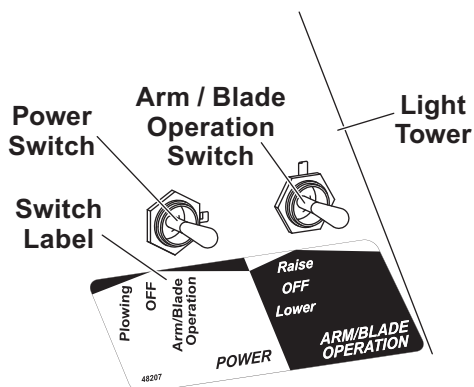

2. Move power switch to center, or "OFF," position.
3. While holding the power switch RIGHT, push DOWN and hold the Arm/Blade Operation switch. The arm will disengage mount adapter and fully retract the lift ram.

4. Remove the breather. Fill to 1" from the top of the reservoir and replace the breather.

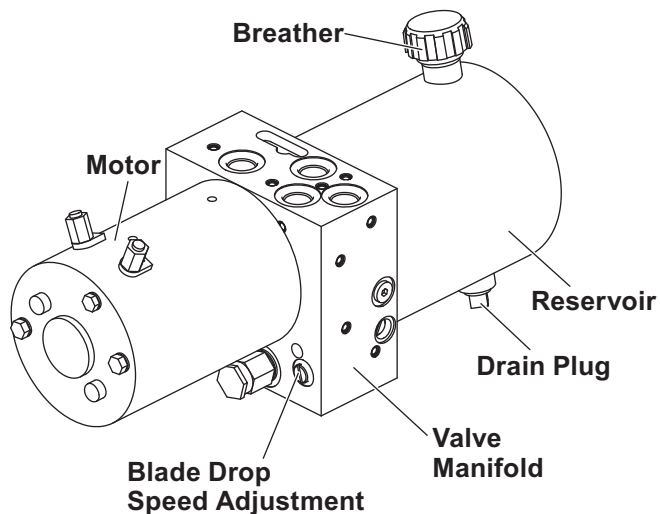

5. Turn control ON. Raise and lower the blade to reposition the draw latch.

For fluid recommendations, see the following Annual Fluid Change instructions.

MAINTENANCE

Annual Fluid Change

CAUTION

Change the fluid at the beginning of each plowing season. Failure to do this could result in condensation buildup during the non-snowplow season.

CAUTION

Do not mix different kinds of hydraulic fluid. Some fluids are not compatible and may cause performance problems and product damage.

1. Perform this operation with the snowplow attached to the vehicle and the vehicle parked on a hard, level surface.
2. Position the blade straight across. Lower the blade to ground and turn the control OFF.
3. While holding the power switch RIGHT, push DOWN and hold the Arm/Blade Operation switch. The arm will disengage the mount adapter and fully retract the lift ram.

NOTE: Loosen the breather slowly to relieve any pressure in the reservoir.

4. Remove the drain plug located in the bottom of the hydraulic reservoir.
5. Completely drain the reservoir and replace the drain plug.

6. With the lift ram fully retracted, fill the reservoir through the fill hole until the fluid is 1" from the top of the reservoir.

Use BLIZZARD® Rapid Action Hydraulic Fluid rated to -40°F (-40°C) or other fluid conforming to Military Specification MIL-H-5606A, such as Mobil Aero HFA or Shell AeroShell® Fluid 4.

7. Replace the breather.
8. Turn the control ON and raise and lower the blade to reposition the draw latch.

WARNING

To prevent accidental movement of the blade, always turn the control OFF whenever the snowplow is not in use. The power indicator light will turn OFF.

MAINTENANCE

FUSE REPLACEMENT

The vehicle control harness contains two automotive-style fuses. The snowplow control and park/turn power are both covered by a 10A fuse. The control fuse is "hot" when the vehicle ignition switch is ON and the electrical connections to the snowplow are completed.

See the Harness Diagram at the end of this manual for fuse ratings and locations.

The hydraulic unit harness system contains three automotive-style mini-fuses. The 3-solenoid coil harness (to port B on the hydraulic unit module) contains two 5A mini-fuses. The 2-solenoid coil harness (to port C on the hydraulic unit module) contains one 5A mini-fuse.

If a problem should occur and fuse replacement is necessary, the replacement fuse must be of the same type and amperage rating as the original. Installing a fuse with a higher rating can damage the system and could start a fire.

VEHICLE

The snowplow operating vehicle shall be maintained according to manufacturer's recommendations. Tire pressure shall be maintained according to manufacturer's recommendation.

RECYCLE

When your snowplow has performed its useful life, the majority of its components can be recycled as steel or aluminum. Hydraulic fluid shall be disposed according to local regulations. Balance of parts made of plastic shall be disposed of in a customary manner.

BLADE FINISH

If the powder-coat finish is nicked or scratched, repair the blade surface with BLIZZARD® white or black paint (available in aerosol or quart cans from your BLIZZARD outlet). Clean and repaint parts as necessary.

EMERGENCY PARTS/TOOLS

We suggest that you keep a BLIZZARD emergency parts kit (PN 40589) in your vehicle. These kits contain BLIZZARD hydraulic fluid, dielectric grease, common hoses, fittings, switches, pins, clips, and a motor relay.

Also keep the following items in your vehicle for emergency use:

- 10" adjustable wrench
- Pliers (locking, adjustable, etc.)
- Medium screwdriver
- 11/16" open-end wrench
- 3/4" open-end wrench
- 5A and 10A automotive-style mini-fuses
- Miscellaneous fasteners

Always use BLIZZARD designed and tested replacement parts.

TROUBLESHOOTING

If you have followed all of the guidelines in the Maintenance section of this manual and cannot resolve issues with the operation of your BLIZZARD snowplow, contact one of our authorized outlets for repair information, or visit us online at www.blizzardplows.com. Our website has a complete listing of authorized outlets in your area as well as a complete library of Parts Lists, Mechanic's Guides, and service information to assist the qualified mechanic with repair.

Blizzard does not recommend repairs by other than our factory-trained outlets. Failure to use an authorized outlet could affect the warranty coverage on your snowplow.



TECHNICAL SPECIFICATIONS

Part	Specification	8600SW
Moldboard	Length	102" (8'6")
	Thickness	12 ga
	Height	29-1/2"
	Reinforcement	4 Ribs @ 1/4"
	Cutting Edge (1080)	1/2" x 6"
	Finish	Powder Coat White
	Trip Mechanism	(4) 3/8" Hooked Extension Springs
A-Frame	Material	Square Tube
	Hitch Pins	3/4" x 8" Yellow Zinc
	Finish	Powder Coat Black
Pump	Construction	Steel Housing w/Steel Tank
	Type	Internal Gear Pump
	Size	2.47 cc
	Motor	12V Starter
	Weight	36 lb
	Mount	A-Frame Install w/Hex Cap Screws
	Reservoir Capacity	1-3/4 qt
Manifold	Construction	Blue Anodized Aluminum
	Valves	Electro-Hydraulic Cartridge
Cylinders	Angle Cylinders	2
	Stroke	11-3/8"
	Rod Diameter	1-3/4"
	Raise/Lower Cylinders	1
	Stroke	5-1/2"
	Rod Diameter	1-1/2"
	Bore Diameter	3-1/2"
Snowplow Headlamps	Type	Low-Profile w/Turn Signals
	Measurements	16" W x 6" H x 9-1/2" D
	Housing	Plastic Composite
	Bulb Type	H13
Snowplow Specs	Weight*	852 lb
	Amperage Draw**	145A
	Adjustable Plow Shoes	(2) Heavy-Duty Cast Steel (Optional)
	Mount Mechanism	Hydraulic Power Switch
	Control Station	Joystick or Hand-Held

* Weight does not include undercarriage or mount adapter.

** Amperage Draw specifications are based on snowplow lift operation, at a shop temperature of 65°F, using BLIZZARD® Rapid Action Hydraulic Fluid. Amperage will vary with temperature, fluid viscosity and meter accuracy. Deadheading a snowplow function will result in significantly increased amperage.

HARNESSES DIAGRAM

⚠ CAUTION

On 2-plug electrical systems, plug covers shall be used whenever the snowplow is disconnected. Vehicle Battery Cable is 12V unfused source.

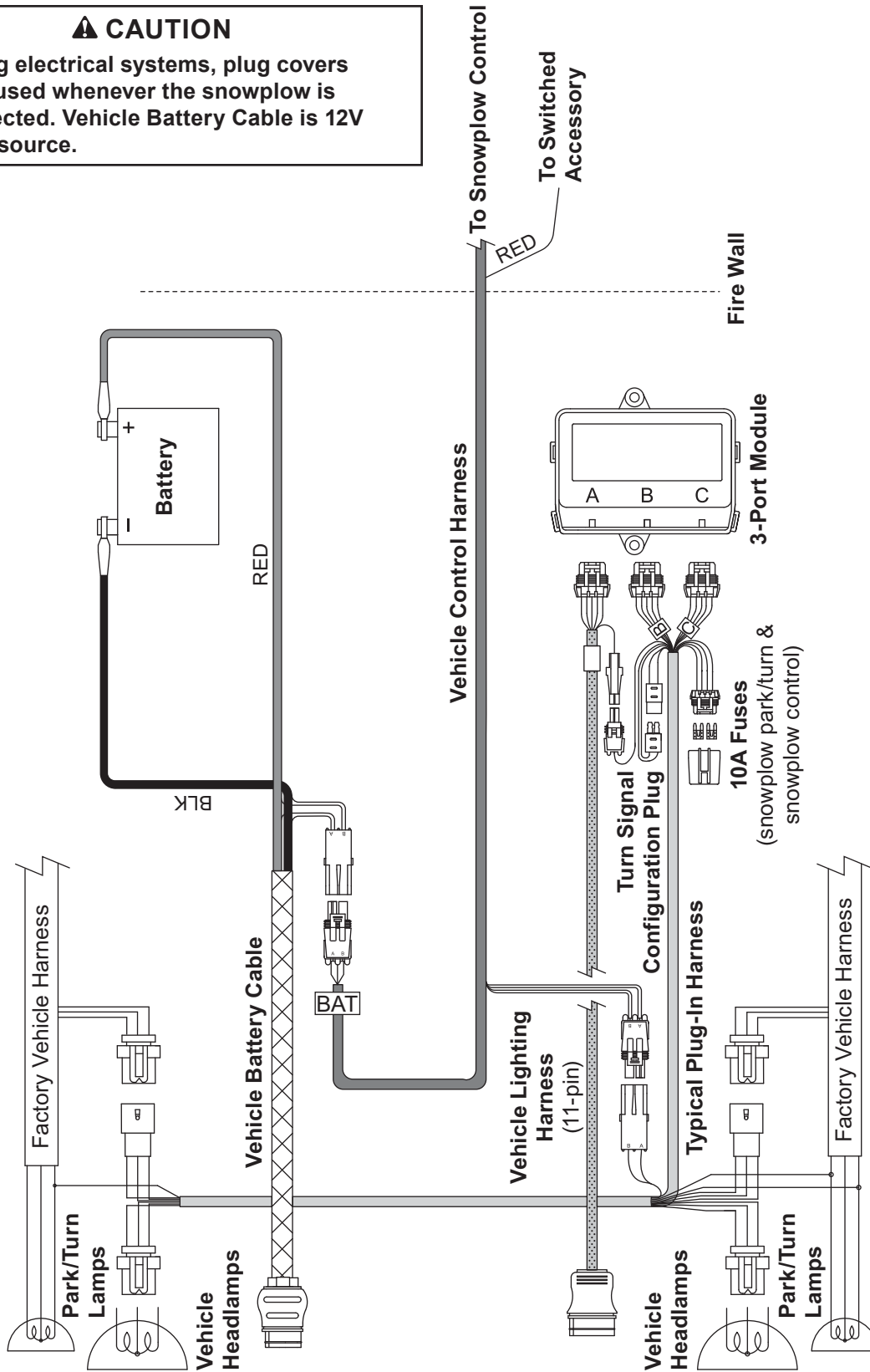



Blizzard
PO Box 245038
Milwaukee, WI 53224-9538
www.blizzardplows.com

 A DIVISION OF DOUGLAS DYNAMICS, LLC



This product conforms to EU Machinery Directive 2006/42/EC.

Copyright © 2021 Douglas Dynamics, LLC. All rights reserved. This material may not be reproduced or copied, in whole or in part, in any printed, mechanical, electronic, film, or other distribution and storage media, without the written consent of Blizzard. Authorization to photocopy items for internal or personal use by Blizzard outlets or snowplow owner is granted.

Blizzard reserves the right under its product improvement policy to change construction or design details and furnish equipment when so altered without reference to illustrations or specifications used. Blizzard or the vehicle manufacturer may require or recommend optional equipment for snow removal. Do not exceed vehicle ratings with a snowplow. This product is manufactured under the following U.S. patents: 6,615,513; 7,134,227; 7,400,058; 7,430,821; 7,737,576; CAN patents: 2,358,145; 2,358,354; and other patents pending. Blizzard offers a limited warranty for all snowplows and accessories. See separately printed page for this important information. The following are registered (®) or unregistered (™) trademarks of Douglas Dynamics, LLC: BLIZZARD®, BLIZZARD POWER PLOW®, POWER GRIP™, POWER HITCH™, POWER HITCH™ 2, POWER PLOW™, SPEEDWING™.

Printed in U.S.A.