



PO Box 245038, Milwaukee, WI 53224-9538 • www.blizzardplows.com

96555

96995

September 15, 2012  
Lit. No. 96478, Rev. 00

# FLEETFLEX

ELECTRICAL SYSTEM

## Joystick Control

### For the FLEET FLEX Electrical System

### Operating Instructions

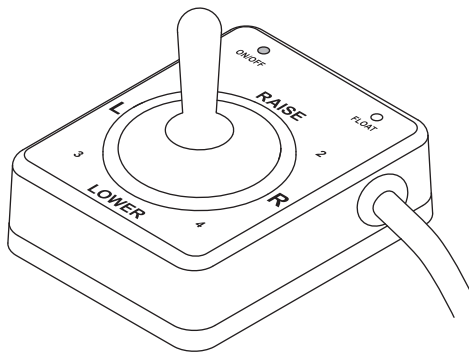

**Straight Blade Snowplows  
(Including SPEEDWING™)  
Joystick Control**

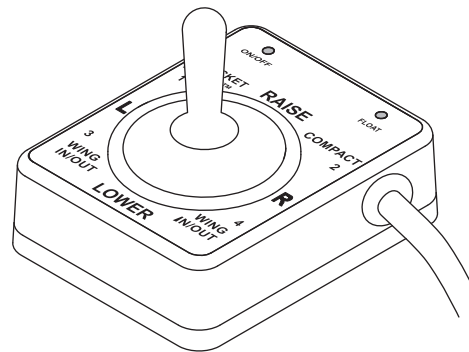

**POWER PLOW™ Joystick Control**

#### **⚠ WARNING**

To prevent accidental movement of the blade, always move the ON/OFF switch to OFF whenever the snowplow is not in use. The power indicator light will turn OFF.

## CONTROL OVERVIEW

Each control is equipped with an ON/OFF switch and an indicator light to show when the control is powered ON or OFF. The controls are powered by the vehicle's battery, so your vehicle ignition (key) switch must be ON to use the controls.

### Straight Blade Control (Including SPEEDWING™)

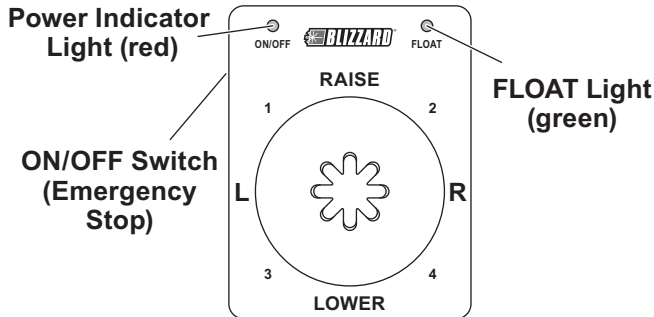

### POWER PLOW™ Control

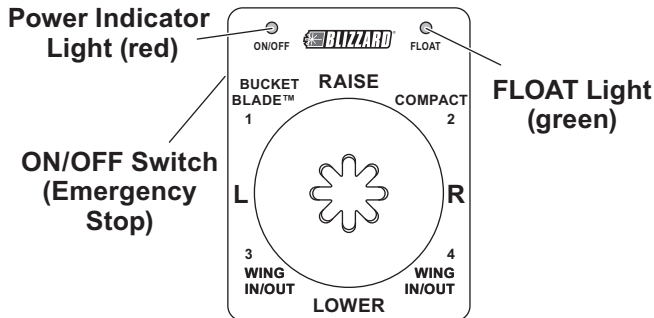

**SECURITY GUARD™ system enabled controls have numbers 1 through 4 on the faceplate.**

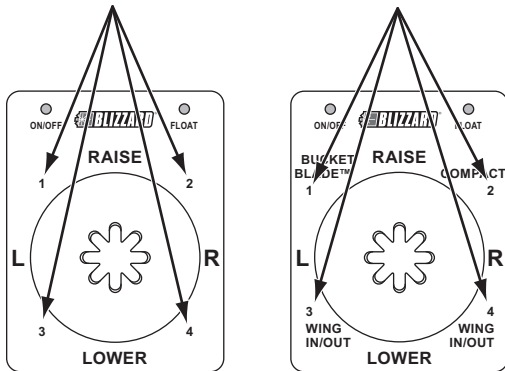

Install the control as stated in the Joystick Control Kit Installation instructions, and check all snowplow functions described in the following pages.

## OPERATING THE JOYSTICK CONTROL

### ⚠ WARNING

**The driver shall keep bystanders clear of the blade when it is being raised, lowered or angled. Do not stand between the vehicle and the blade or within 8 feet of a moving blade. A moving or falling blade could cause personal injury.**

1. Turn the vehicle ignition switch to the "ON" or "ACCESSORY" position.
2. Move the slide switch on the side of the control to the "ON" position. The power indicator light glows red, indicating that the control is ON. The indicator light glows red whenever the control and the vehicle ignition switch are both ON and the electrical connections to the snowplow are completed.

The ON/OFF switch operates as an emergency stop, if required.

### Function Time-Outs

All control functions, except LOWER/FLOAT, time out (stop) automatically after a period of time. This is to limit the amount of electrical energy required from the vehicle.

**NOTE: If a control function times out before desired blade movement is complete, release the lever to the center position, then move it back into the desired function.**

### Automatic Shutdown

The control will automatically turn OFF after being idle for 20 minutes. To reactivate the control after a shutdown, move the ON/OFF switch to OFF, then back to ON.

### Smooth Stop/Soft Stop

The control automatically allows the blade to coast to a stop when the lever returns to center position. This results in smoother operation, reduces the shock to the hydraulic system and increases hose and valve life. See the FLEET FLEX Electrical System section for more information about this feature.

### Control Lever Movement

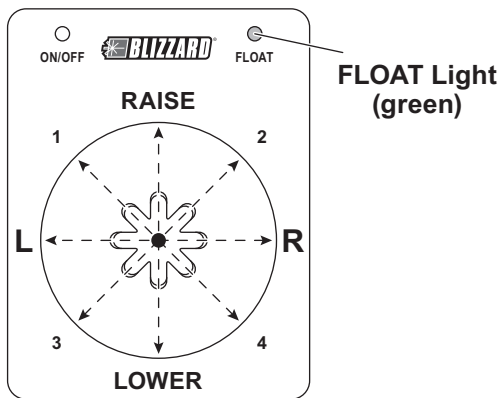

From the center position, the control lever can be moved in one of eight directions to control various movements of the snowplow blade. To change from one movement of the blade to another, the control lever must be moved back to the center position before selecting the desired function. Whenever the lever is released, it should spring back into the center position to stop any blade movement.

### Control Functions – Straight Blade Snowplows

Moving the control lever straight up and down or from side to side on the control body will result in the blade movements described in the following table.

Function	Description of Operation
<b>RAISE</b>	Move the control lever toward the top of the control body to raise the blade and cancel the FLOAT mode. Function times out after 3.5 seconds.
<b>LOWER</b>	Move the control lever toward the bottom of the control body to lower the blade. Release the lever to stop the blade at desired height.
<b>FLOAT*</b>	Move the control lever to the <b>LOWER</b> position and hold 3/4 second to activate this mode. The FLOAT indicator light in the upper right corner of the control face will illuminate. The blade will lower to the ground surface and follow the contour of the surface as it dips or rises. Function does not time out; however, the control will shut down after 20 minutes of nonuse. Move the lever to the <b>RAISE</b> position momentarily to cancel FLOAT. Angling left or right will not interrupt (pause) the FLOAT function.
<b>L (Angle Left)</b>	Move the control lever straight to the left to angle the blade left. Function times out after 3.5 seconds.
<b>R (Angle Right)</b>	Move the control lever straight to the right to angle the blade right. Function times out after 3.5 seconds.

\* FLOAT mode activates immediately when the One-Touch FLOAT feature is enabled. See the One-Touch FLOAT section for more information.

**NOTE: If a control function times out before desired blade movement is complete, release the lever to the center position, then move it back to the desired function.**

**Control Functions – POWER PLOW™**

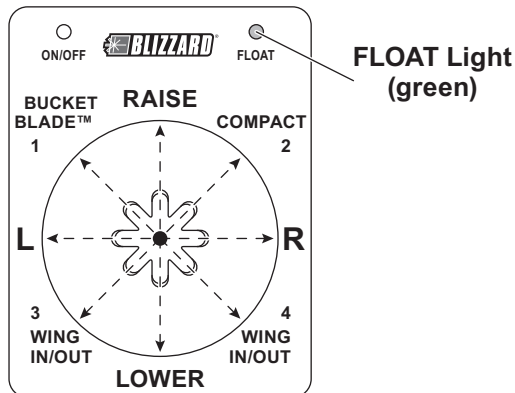

**Raise, Lower, FLOAT, Angle**

Moving the control lever straight up and down or from side to side on the control body will result in the blade movements described in the following table.

Function	Description of Operation
<b>RAISE</b>	Move the control lever toward the top of the control body to raise the blade and cancel the FLOAT mode. Function times out after 6.25 seconds.
<b>LOWER</b>	Move the control lever toward the bottom of the control body to lower the blade. Release the lever to stop the blade at the desired height.
<b>FLOAT*</b>	Move the control lever to the <b>LOWER</b> position and hold 3/4 second to activate this mode. The FLOAT light in the upper right corner of the control face will illuminate. The blade will lower to the ground surface and follow the contour of the surface as it dips or raises. Function does not time out; however, control will shut down after 20 minutes of nonuse. Move the lever to the <b>RAISE</b> position momentarily to cancel FLOAT. Angling left or right will not interrupt (pause) the FLOAT function.
<b>L (Angle Left)</b>	Move the control lever straight to the left to move the blade to the angle left position. The left wing retracts while the right wing extends. Function times out after 4.5 seconds.
<b>R (Angle Right)</b>	Move the control lever straight to the right to move the blade to the angle right position. Function times out after 4.5 seconds.

\* FLOAT mode activates immediately when the One-Touch FLOAT feature is enabled. See the One-Touch FLOAT section for more information.

**BUCKET BLADE™/ Compact Blade Positions**

Moving the control lever from the center position toward "BUCKET BLADE" or "COMPACT" on the face of the control body will cause both wings to move at the same time as described in the following table.

Function	Description of Operation
<b>BUCKET BLADE</b>	Move the control lever toward the words BUCKET BLADE on the control face to extend both wings forward into the scoop position. Function times out after 8.25 seconds.
<b>COMPACT</b>	Move the control lever toward the word COMPACT on the control face to draw both wings into the fully retracted position. Function times out after 6.5 seconds.

**Wing Positions**

Moving the control lever from the center position toward "L WING IN/OUT" or "R WING IN/OUT" on the face of the control body will cause one wing to move independently of the other, as described in the following table.

Function	Description of Operation
<b>L WING IN/OUT</b>	Move the control lever toward the <i>left</i> side of <b>LOWER</b> on the control face to move the left wing. The first time the lever is moved into the slot after the control is turned ON or another function is used, the wing will extend. Repeated use of the lever in the same slot, without using another function, results in movement in the opposite direction from the previous movement. Function times out after 4.5 seconds.
<b>R WING IN/OUT</b>	Move the control lever toward the <i>right</i> side of <b>LOWER</b> on the control face to move the right wing. The first time the lever is moved into the slot after the control is turned ON or another function is used, the wing will extend. Repeated use of the lever in the same slot, without using another function, results in movement in the opposite direction from the previous movement. Function times out after 4.5 seconds.

**NOTE: If a control function times out before desired blade movement is complete, release the lever to the center position, then move it back to the desired function.**

## FLEET FLEX ELECTRICAL SYSTEM

POWER HITCH™ 2 system snowplows come standard with user-controlled programmable features. These include:

- SECURITY GUARD™ electrical anti-theft system
- Smooth Stop
- One-Touch FLOAT

## SECURITY GUARD System

The SECURITY GUARD electrical anti-theft system provides a deterrent against theft or non-permitted use by electronically locking the snowplow's hydraulic functions.

To activate this function, set up a 4-digit security code as described below.

### Activation & Establishing a 4-Digit Security Code

**NOTE: The snowplow must be attached to the vehicle, and all the electrical connections must be connected prior to activating the security code function.**

1. Turn the vehicle ignition switch to the "ON" or "ACCESSORY" position. (It is not necessary to start the vehicle.)
2. Verify that the control is OFF. If the power indicator light is red, the control is ON. Slide the ON/OFF switch to "OFF" to turn the control OFF.
3. Activate the SECURITY GUARD mode by moving the control lever into the #1 position four consecutive times, then moving it into the #4 position four consecutive times (sequence: 1, 1, 1, 1, 4, 4, 4, 4). The green FLOAT light will flash rapidly and the red power indicator light will turn ON, indicating that the system is ready to accept your 4-digit security code.

Enter your 4-digit security code by moving the control lever into any of the eight possible positions, in any sequence: UP, DOWN, LEFT, RIGHT, 1, 2, 3 or 4.

The FLOAT light will stop flashing and the power indicator light will turn OFF, indicating that the 4-digit security code is now programmed into the SECURITY GUARD system.

4. Once a 4-digit security code has been established, the SECURITY GUARD system will recognize any control that has been programmed with the same 4-digit security code. If a control not programmed with the correct 4-digit security code is connected to the system, the established security code will have to be entered manually before the snowplow can be activated (see the manual unlock procedure instructions below).

**NOTE: If the control is turned ON prior to completing the programming procedure, your 4-digit security code will be cancelled.**

### Manual Unlock

The manual unlock procedure allows a control programmed with a different 4-digit security code to unlock a locked snowplow.

1. Turn the vehicle ignition to the "ON" or "ACCESSORY" position.
2. Turn the control ON/OFF switch to the "ON" position.
3. The power indicator light will flash rapidly, indicating that the snowplow is locked.
4. Enter the 4-digit security code.
5. After the correct security code is entered, the power indicator light will change from flashing rapidly to a solid light to indicate that the snowplow has been successfully unlocked.

**NOTE: If the plow/vehicle electrical connection is lost or disconnected, the SECURITY GUARD system will reset, requiring any control that is not programmed with the established 4-digit security code to manually re-enter the security code to activate the snowplow.**

## Clearing an Established 4-Digit Security Code

1. Turn the vehicle ignition switch to the "ON" or "ACCESSORY" position.
2. If the snowplow is locked (the control POWER light will be flashing rapidly), unlock it by following the Manual Unlock procedure.
3. Slide the control ON/OFF switch to "OFF." Verify that the power indicator light is OFF.
4. With the control OFF, move the control lever to the #2 position four consecutive times, and then to the #3 position four consecutive times. This sequence (2, 2, 2, 2, 3, 3, 3, 3) will clear the 4-digit security code from the SECURITY GUARD™ system. The FLOAT light will flash to indicate that the 4-digit security code was cleared.

---

**NOTE: To enter a new 4-digit security code, see "Activation & Establishing a 4-Digit Security Code."**

---

## Light Flash Indicators

POWER – Red	Function
Off	Control is OFF
Solid ON	Control is ON and active
Slow flash	No communication
Fast flash	Plow is locked – enter 4-digit security code to unlock

FLOAT – Green	Function
Solid ON	Float function is active
Fast flash	Security code activation in progress

## Additional Notes

- The SECURITY GUARD system requires any control other than the one with the assigned 4-digit security code to enter the security code before the snowplow can be activated. Once the security code is established, the SECURITY GUARD system recognizes that a control with the same security code is attached, and does not require a manual unlock to activate the snowplow. The system will recognize the control as "safe" and will automatically unlock.
- In the event that a snowplow is locked and cannot be manually unlocked or reset, contact your Authorized Distributor.
- REMINDER: Record your security code for future reference.

## Smooth Stop

Smooth Stop, or "soft" stop, allows the blade to coast to a stop when the control lever is released. The result is smoother operation, reduced shock to the hydraulic system and increased hose and valve life.

While there are advantages to having this feature, there are also advantages to temporarily disabling it. For example, disabling Smooth Stop allows for more precise movements of the blade when operating close to buildings and other obstacles.

All controls come standard with Smooth Stop ENABLED. To enable/disable this feature, perform the following steps.

### Enable/Disable Procedure

1. Turn the vehicle ignition switch to the "ON" or "ACCESSORY" position. (It is not necessary to start the vehicle.)
2. Verify that the control power indicator is OFF. If the power indicator light is red, the control is ON. Move the ON/OFF switch to "OFF" to turn the control OFF.
3. Hold the control lever in the R position while turning the control ON. The power indicator light will turn ON and the FLOAT light will flash, indicating the status of the feature.

### Light Flash Indicators

Light	Description
POWER – red	Solid on = control is ON
FLOAT – green	1 flash = Smooth Stop enabled 2 flashes = Smooth Stop disabled

Performing the sequence multiple times will toggle the Smooth Stop feature between enabled and disabled.

## One-Touch FLOAT

One-Touch FLOAT immediately activates the FLOAT mode and releases the blade to the ground without having to hold the lever in the LOWER position. This can improve transition time when backing up to plow forward again, eliminating the time spent holding the control and waiting for the blade to fully drop.

All controls come standard with One-Touch FLOAT DISABLED. To enable/disable this feature, perform the following steps.

### Enable/Disable Procedure

1. Turn the vehicle ignition switch to the "ON" or "ACCESSORY" position. (It is not necessary to start the vehicle.)
2. Verify that the control power indicator is OFF. If the power indicator light is red, the control is ON. Move the ON/OFF switch to "OFF" to turn the control OFF.
3. Hold the control lever in the LOWER position while turning the control ON. The power indicator light will turn ON and the FLOAT light will flash, indicating the status of the feature.

### Light Flash Indicators

Light	Description
POWER – red	Solid ON = control is ON
FLOAT – green	1 flash = One-Touch FLOAT disabled 2 flashes = One-Touch FLOAT enabled

Performing the sequence multiple times will toggle the One-Touch FLOAT feature between enabled and disabled.

Blizzard reserves the right under its product improvement policy to change construction or design details and furnish equipment when so altered without reference to illustrations or specifications used. Blizzard or the vehicle manufacturer may require or recommend optional equipment for snow removal. Do not exceed vehicle ratings with a snowplow. Blizzard offers a limited warranty for all snowplows and accessories. See separately printed page for this important information. The following are registered (®) or unregistered (™) trademarks of Douglas Dynamics, L.L.C.: BLIZZARD®, BUCKET BLADE™, POWER HITCH™ 2, POWER PLOW™, SECURITY GUARD™, SPEEDWING™.

**Printed in U.S.A.**

---