

69804, 69805, 69818

HARNESS KIT

3-PORT ISOLATION MODULE

LIGHT SYSTEM

w/PROJECTOR-STYLE VEHICLE LIGHTING

Parts List and Installation Instructions

⚠ CAUTION

Read this document before installing the snowplow.

⚠ CAUTION

See your sales outlet/website for specific vehicle application recommendations before installation. The online selection system has specific vehicle and snowplow requirements.

PARTS LIST

Projector-Style Light System Plug-In Harness						
Part	Description	Qty				
		69804	69818	69805	29047	
29860	Vehicle Lighting Harness – 11 Pin w/Relays	1	1			
69803	Plug-In Harness, HIR2/HB-3	1				
69817-1	Plug-In Harness, HB-3/H11/HIR2		1			
69793	Vehicle Lighting Harness – 11 Pin w/Relays, HID			1		
69798	Plug-In Harness, HID			1		
29047	Adapter, 3-Port to 26345/26346 Vehicle Control Harness				1	
43782	Edging Material		1			
–	Reclosable Fasteners	4	4	4		
–	Splices			1		
–	Heatshrink Tubing			1		
–	Information Label – Lamp Out Message	1				
–	Service Literature – Lamp Out Message	1				

SAFETY DEFINITIONS

WARNING

Indicates a potentially hazardous situation that, if not avoided, could result in death or serious personal injury.

CAUTION

Indicates a potentially hazardous situation that, if not avoided, may result in minor or moderate injury. It may also be used to alert against unsafe practices.

NOTE: Indicates a situation or action that can lead to damage to your snowplow and vehicle or other property. Other useful information can also be described.

FUSES

The snowplow electrical and hydraulic systems contain several blade-style automotive fuses. If a problem should occur and fuse replacement is necessary, the replacement fuse must be of the same type and amperage rating as the original. Installing a fuse with a higher rating can damage the system and could start a fire. Fuse Replacement, including fuse ratings and locations, is located in the Maintenance section of the Owner's Manual.

BATTERY SAFETY

CAUTION









Batteries normally produce explosive gases, which can cause personal injury. Therefore, do not allow flames, sparks or lit tobacco to come near the battery. When charging or working near a battery, always cover your face and protect your eyes, and also provide ventilation.

- Batteries contain sulfuric acid, which burns skin, eyes and clothing.
- Disconnect the battery before removing or replacing any electrical components.

TORQUE CHART

CAUTION

Read instructions before assembling. Fasteners should be finger tight until instructed to tighten according to the torque chart. Use standard methods and practices when attaching snowplow, including proper personal protective safety equipment.

Recommended Fastener Torque Chart					
Inch Fasteners Grade 5 and Grade 8					
Size	Torque (ft-lb)		Size	Torque (ft-lb)	
	 Grade 5	 Grade 8		 Grade 5	 Grade 8
1/4-20	8.4	11.9	9/16-12	109	154
1/4-28	9.7	13.7	9/16-18	121	171
5/16-18	17.4	24.6	5/8-11	150	212
5/16-24	19.2	27.3	5/8-18	170	240
3/8-16	30.8	43.6	3/4-10	269	376
3/8-24	35.0	49.4	3/4-16	297	420
7/16-14	49.4	69.8	7/8-9	429	606
7/16-20	55.2	77.9	7/8-14	474	669
1/2-13	75.3	106.4	1-8	644	909
1/2-20	85.0	120.0	1-12	704	995
Metric Fasteners Class 8.8 and 10.9					
Size	Torque (ft-lb)		Size	Torque (ft-lb)	
	 Class 8.8	 Class 10.9		 Class 8.8	 Class 10.9
M6 x 1.00	7.7	11.1	M20 x 2.50	325	450
M8 x 1.25	19.5	26.9	M22 x 2.50	428	613
M10 x 1.50	38.5	53.3	M24 x 3.00	562	778
M12 x 1.75	67	93	M27 x 3.00	796	1139
M14 x 2.00	107	148	M30 x 3.50	1117	1545
M16 x 2.00	167	231	M33 x 3.50	1468	2101
M18 x 2.50	222	318	M36 x 4.00	1952	2701
These torque values apply to fasteners except those noted in the instructions.					

TYPICAL 2-PLUG, 3-PORT MODULE SYSTEM DIAGRAM

⚠ CAUTION
 On 2-plug electrical systems, plug covers shall be used whenever snowplow is disconnected. Vehicle Battery Cable is 12-volt unfused source.

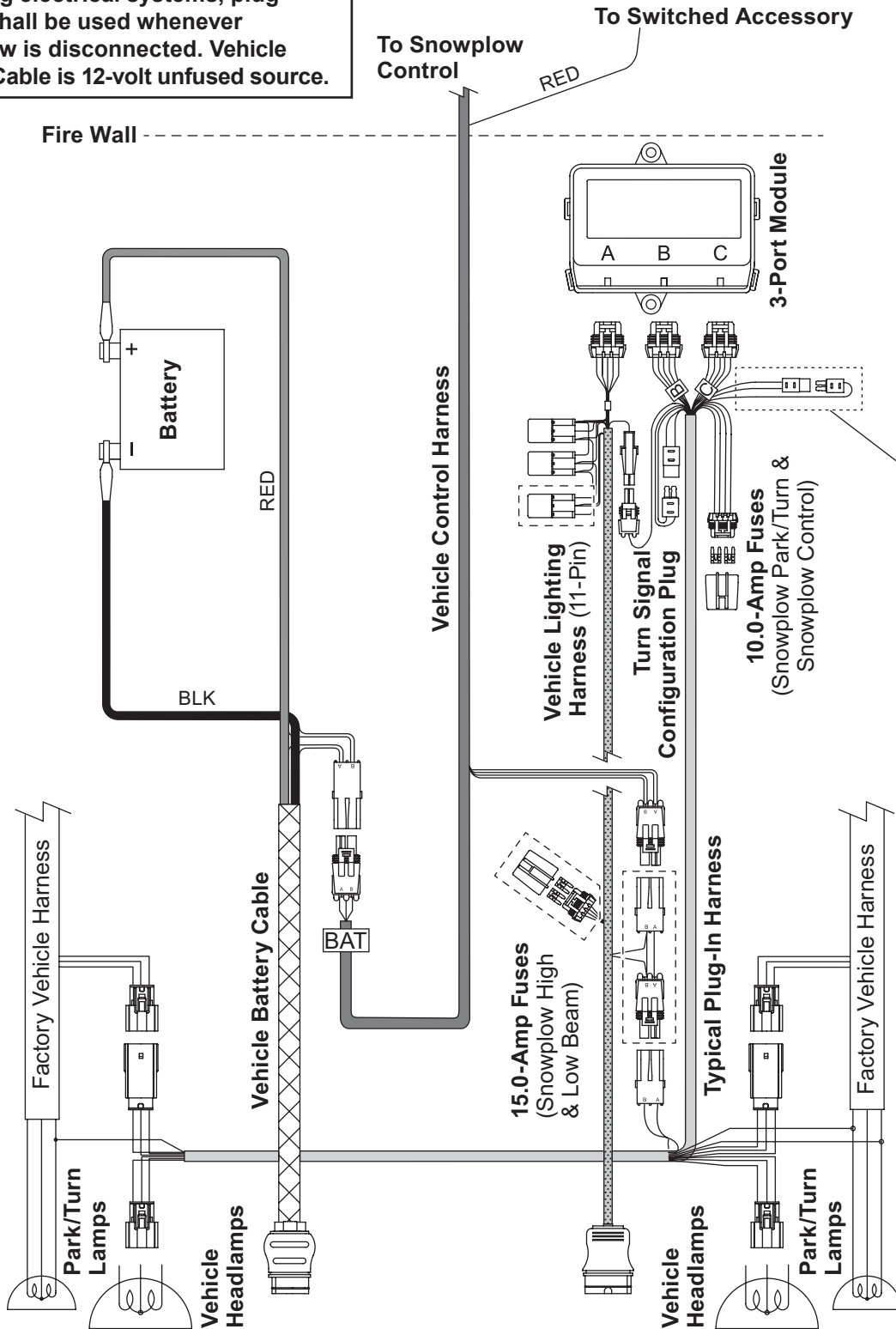

Pink wires on 69817 plug-in harness not used. Align plugs so that the single pink wire connects to the wire labeled "DRL1" and plug them together. Not included on all harnesses.

[] = 69805 Harness Kit only

TYPICAL 3-PLUG, 3-PORT MODULE SYSTEM DIAGRAM

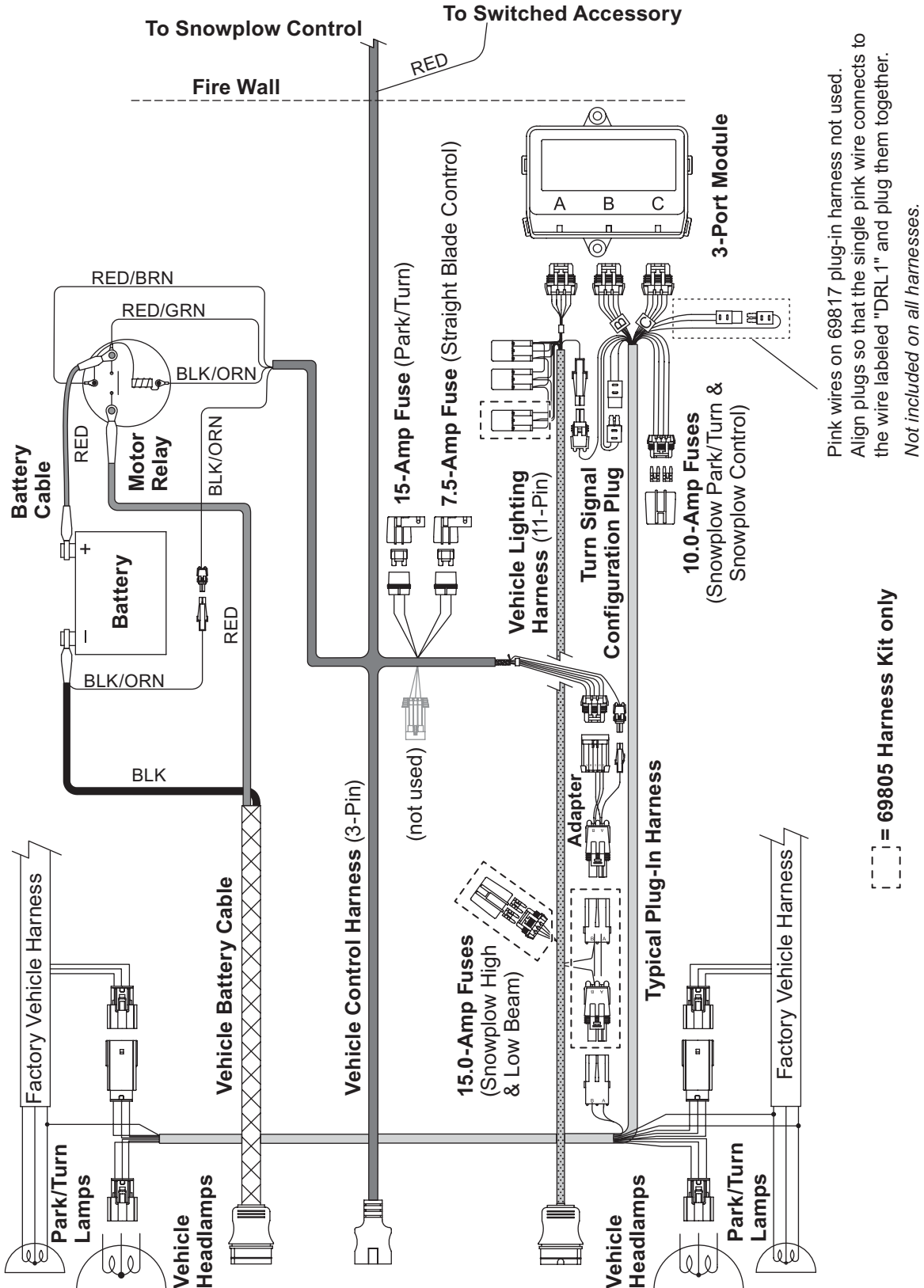

INSTALLATION INSTRUCTIONS

Isolation Module Mounting

⚠ CAUTION

Before installing self-drilling screws or drilling mounting holes, check the selected mounting area for any wires, hoses or other obstructions.

Isolation modules are sold separately. Check the online selection system for the correct module for your vehicle.

2014 and Newer Chevy and GMC Vehicles 69818 Harness Kit Only

1. The driver-side headlamp must be removed to allow access to the inside of the driver-side fender where the isolation module must be installed. Before the headlamp can be removed, the truck bumper and grille must be removed.
2. Remove the truck bumper, grille, and headlamp trim. See the mount kit installation instructions for bumper, grille, and headlamp trim removal steps.



3. Install the edging material around the sides of the fender well as shown.

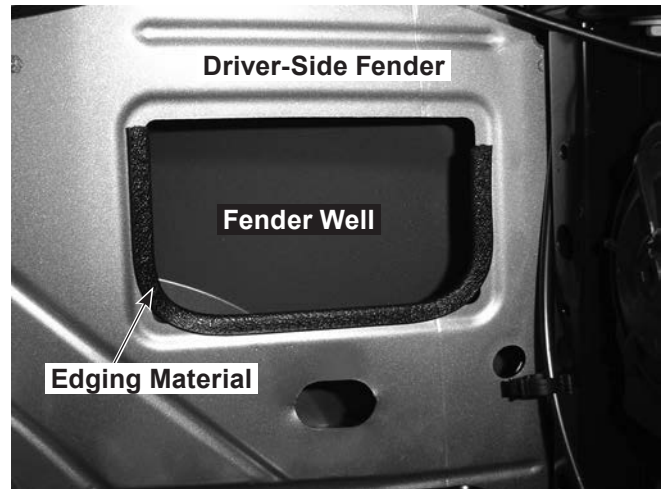

4. Remove the cable clip currently in place above the fender well. Drill a 5/16" hole approximately 1/2" above the existing cable clip hole.

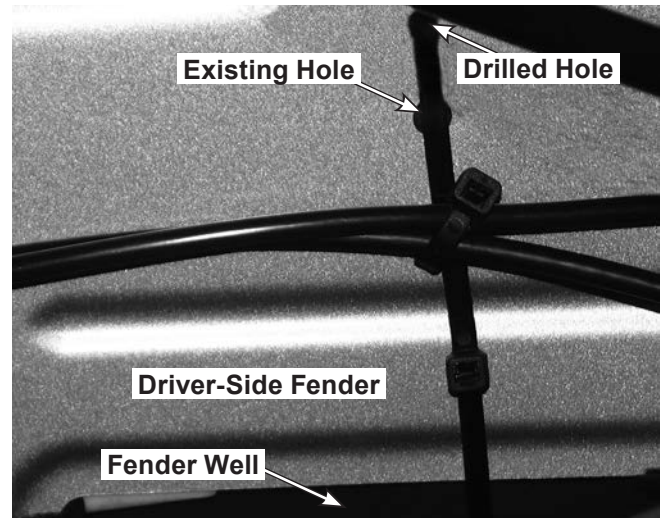

5. Remove the driver-side headlamp and disconnect the harness. See mount kit installation instructions for details.
6. Slide the isolation module between the driver-side fender and the outer wall.

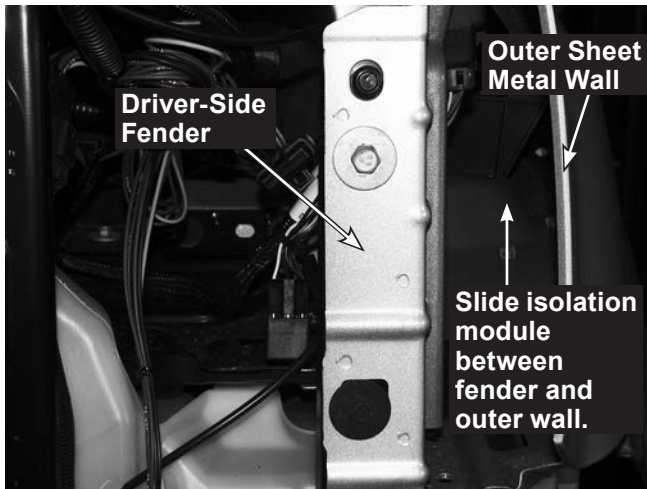

Install the isolation module on the inside of the driver-side fender using the supplied cable ties, reclosable fastener strips, and edging material as shown below.

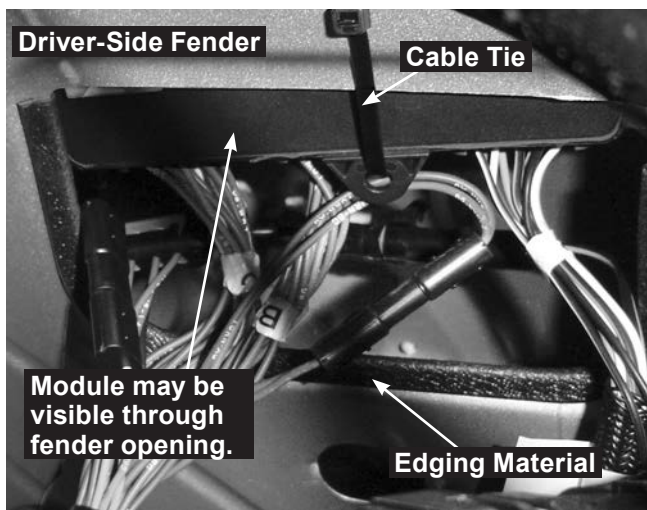

Notching Radiator Shroud (2014 and newer GM half-ton trucks)

On vehicles with enclosed radiator shrouds, the upper edge of the shroud must be notched on both the driver's side and passenger's side to allow space for cables to be routed to the area behind the vehicle grille. Cut notches as required, following the example of the existing notch for OEM wiring on the passenger side of the shroud.

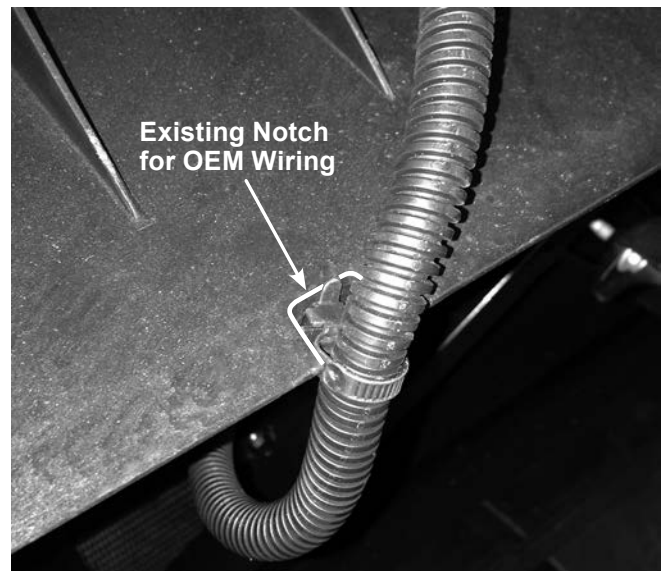

All Other Vehicles

Locate a flat surface within the engine compartment of the vehicle for mounting the isolation module (**on the driver's side, if possible**). The fire wall, fender well or radiator shroud are possible mounting locations. If a suitable flat surface is not accessible, cable tie the isolation module to existing brackets or harnessing.

Reclosable fastener strips and/or cable ties are supplied for mounting the isolation module, but self-drilling screws can also be used. When using reclosable fastener strips, the mounting surface must be free of dirt and grease.

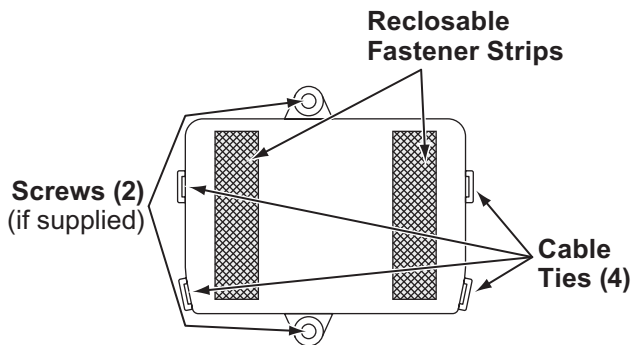

Isolation Module (bottom view)

69804 Harness Kit Only

NOTE: With snowplow attached, the dashboard message center may flash a "Low Beam Headlight Out" notice when lights are switched from low beam to high beam. Disregard the message. Low beam lights will function normally.

TWO-PLUG SYSTEM

Vehicle Battery Cable Installation

⚠ CAUTION

Batteries normally produce explosive gases, which can cause personal injury. Therefore, do not allow flames, sparks or lit tobacco to come near the battery. When charging or working near a battery, always cover your face and protect your eyes, and also provide ventilation.

- Batteries contain sulfuric acid, which burns skin, eyes and clothing.
- Disconnect the battery before removing or replacing any electrical components.

NOTE: When instructed, make all snowplow battery cable connections to the auxiliary battery, if vehicle is so equipped.

NOTE: Use dielectric grease on all electrical connections to prevent corrosion. Fill receptacles and lightly coat ring terminals before assembly.

1. Turn OFF the vehicle ignition.
2. Disconnect both the NEGATIVE (-) and the POSITIVE (+) battery cables.
3. Route the supplied vehicle battery cable from the grille or bumper to the battery, avoiding any sharp edges and hot or moving parts. Cable tie only the end section closest to the grille.
4. Route the red wire from the vehicle battery cable to the POSITIVE (+) battery terminal. Do not connect at this time.
5. Route the black wire from the vehicle battery cable to the NEGATIVE (-) battery terminal. *Do not connect at this time.* The 4-position connector from the vehicle battery cable will connect to the mating connector (labeled "BAT") on the end of the vehicle control harness.

Vehicle Lighting and Vehicle Control Harness Installation

1. Route both harnesses around or through the radiator bulkhead to the isolation module.
2. Connect the 4-position connector from the vehicle lighting harness to the matching 4-position connector from the vehicle control harness.
3. Connect the vehicle lighting harness to position "A" on the isolation module.
4. Route the end of the vehicle control harness with the white 4-pin connector to the fire wall.

Connect the black 4-position connector (labeled "BAT") from the end of the vehicle control harness to the 4-position connector from the vehicle battery cable. Do not cable tie the harness at this time.

CAUTION

Before installing self-drilling screws or drilling mounting holes, check the selected mounting area for any wires, hoses or other obstructions.

5. On the driver's side, locate an existing hole through the fire wall for the vehicle control harness. If access through the fire wall does not exist, drill a 5/8" hole through the fire wall in a convenient location away from sharp edges and hot or moving parts.
6. Push the braided harness breakout with the cab control connector through the fire wall hole into the cab. Use a grommet, existing plug cover or proper chafing material to protect the harness where it passes through the fire wall. Route the harness to the selected control mounting location.

To mount the control, follow the instructions supplied with the control.
7. Locate an accessory wire controlled by the ignition switch. Acceptable accessory wires show +12V when the ignition switch is turned ON, and 0V when it is OFF.
8. Route the red "ACC" wire from the vehicle control harness to this location and trim away excess length.
9. Following the recommended splicing procedure given at the end of this document, splice the red "ACC" wire into the switched accessory wire using the supplied parallel splices and heatshrink tubing.

THREE-PLUG SYSTEM

Motor Relay and Vehicle Battery Cable Installation

⚠ CAUTION

Batteries normally produce explosive gases, which can cause personal injury. Therefore, do not allow flames, sparks or lit tobacco to come near the battery. When charging or working near a battery, always cover your face and protect your eyes, and also provide ventilation.

- Batteries contain sulfuric acid, which burns skin, eyes and clothing.
- Disconnect the battery before removing or replacing any electrical components.

NOTE: When instructed, make all snowplow battery cable connections to the auxiliary battery, if vehicle is so equipped.

1. Turn OFF the vehicle ignition.
2. Disconnect both the NEGATIVE (–) and the POSITIVE (+) battery cables.
3. Choose a location on the vehicle where the motor relay will be protected from road splash and debris. Motor relay must be within 18" of the vehicle battery. (The motor relay can be farther from the battery if the battery cable provided with either the plug-in harness or adapter kit is longer than 22".)

NOTE: Position motor relay terminals up, horizontal or in between.

⚠ CAUTION

Before installing self-drilling screws or drilling mounting holes, check the selected mounting area for any wires, hoses or other obstructions.

4. Drill two 9/32" mounting holes using the motor relay mounting plate as a template. Mount the motor relay using 1/4" x 3/4" cap screws, washers, and locknuts.

5. Route the supplied vehicle battery cable from the grille or bumper to the location chosen for mounting the motor relay, avoiding any sharp edges and hot or moving parts. Cable tie only the end section closest to the grille.

⚠ CAUTION

Overtightening terminal attaching nuts may cause seal failure, resulting in premature failure of motor relay.

6. Attach the red wire from the vehicle battery cable to one of the large terminals on the motor relay. Secure with a lock washer and 5/16" nut, and tighten to a maximum of 35 in-lb.

Red Vehicle Battery Cable
(Tighten nut to max. 35 in-lb)

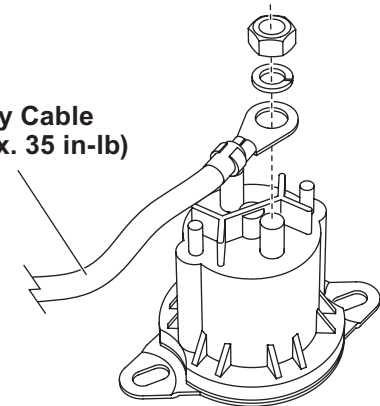

NOTE: Use dielectric grease on all electrical connections to prevent corrosion. Fill receptacles and lightly coat ring terminals before assembly.

7. Route the black wire from the vehicle battery cable to the NEGATIVE (–) battery terminal. *Do not connect at this time.* The black/orange wire from the vehicle battery cable will connect to the mating connector on the vehicle control harness.

Vehicle Lighting and Vehicle Control Harness Installation

Vehicle lighting and vehicle control harnesses are designed to plug into one another when the snowplow is not attached. Plug the harnesses together before cable tying them to ensure adequate length.

1. Route both harnesses around or through the radiator bulkhead to the isolation module.
2. Make the following connections:
 - 10-position connector from vehicle control harness to 10-position connector from adapter included with harness kit.
 - Single-wire connector from vehicle control harness to single-wire connector from adapter included with harness kit.
 - 4-position connector from adapter included with hydraulic kit to 4-position connector from vehicle lighting harness.
 - Vehicle lighting harness to position "A" on the isolation module.

NOTE: The 3-position connector on the vehicle control harness will not be used. Cover the terminals with dielectric grease and cap off with electrical tape.

3. Route the end of the vehicle control harness with the white 6-pin connector to the fire wall. Route the vehicle control harness breakout with four wires to the motor relay.

⚠ CAUTION

Overtightening terminal attaching nuts may cause seal failure, resulting in premature failure of motor relay.

Secure the brown/red and black/orange wires to the small terminals of the motor relay with #10 lock washers and 10-32 nuts, and tighten to a maximum 15 in-lb.

4. Connect the single-wire connector (black/orange wire) from the vehicle control harness breakout to the single-wire connector (black/orange wire) from the vehicle battery cable. Do not cable tie the harness at this time.
5. Attach the supplied red battery cable and the red/green wire from the vehicle control harness to a large terminal on the motor relay with a lock washer and 5/16" nut and tighten to a maximum 35 in-lb. Route the supplied red battery cable between motor relay terminal and POSITIVE (+) battery terminal, avoiding sharp edges and hot or moving parts. *Do not connect at this time.*

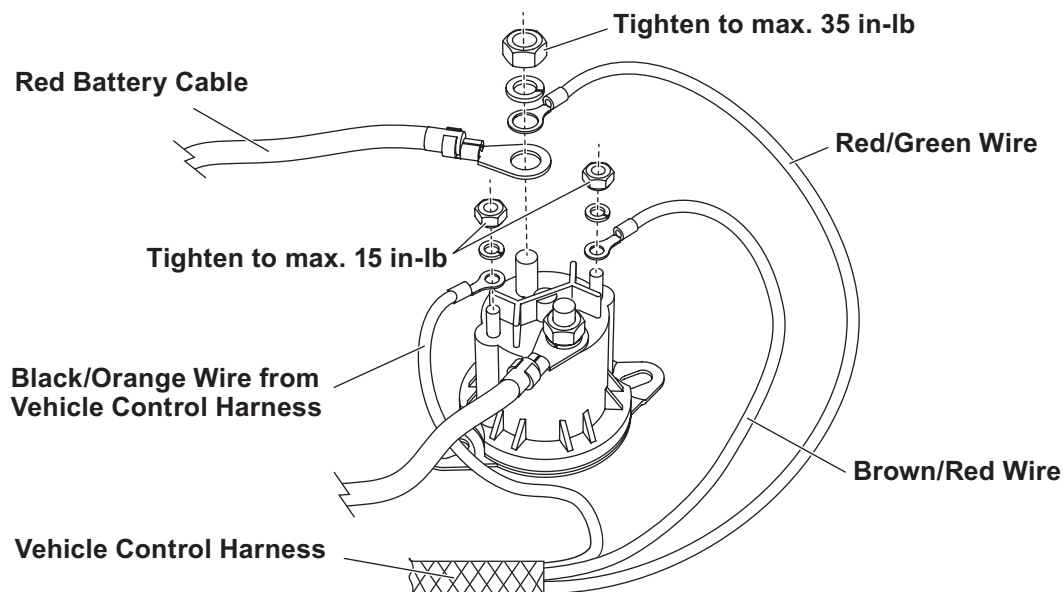

⚠ CAUTION

Before installing self-drilling screws or drilling mounting holes, check the selected mounting area for any wires, hoses or other obstructions.

6. On the driver's side, locate an existing hole through the fire wall for the vehicle control harness. If access through the fire wall does not exist, drill a 5/8" hole through the fire wall of the vehicle in a convenient location away from sharp edges and hot or moving parts.
7. Locate an accessory wire controlled by the ignition switch. Acceptable accessory wires show +12V when the ignition switch is ON, and 0V when it is OFF.
8. Route the red wire from the vehicle control harness to this location and trim away excess length.
9. Following the recommended splicing procedure given at the end of this document, splice the red wire into the switched accessory wire using the supplied parallel splices and heatshrink tubing.

PLUG COVER INSTALLATION

1. Stretch the rectangular opening of the plug cover strap over the end of the vehicle battery cable. Place the plug cover over the molded plug when snowplow is not in use.

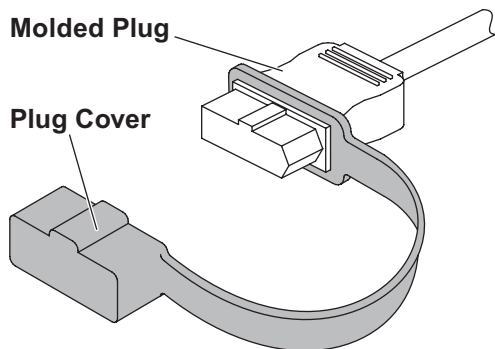

PLUG-IN HARNESS INSTALLATION

1. Remove the headlamp or headlamp housing connectors. Connect the plug-in harness to the mating connectors removed from the headlamps or headlamp housings. Connect the plug-in harness to the mating connections at the headlamps or headlamp housings.
2. Route the plug-in harness to the isolation module. Connect the plug-in harness to the module by matching harness connector B with module port B and harness connector C with module port C.
3. Connect the 4-position connector on the vehicle lighting harness to the matching 4-position connector on the plug-in harness.
4. Connect the single-wire connector from the vehicle lighting harness to the single-wire connector from the plug-in harness.
5. **Ford vehicles only (69805 plug-in harness):** Locate the turn signal wire on each side of the vehicle. Splice the "TURN" wire from the plug-in harness into the signal wire on the corresponding side following the recommended splicing procedure given at the end of this document.

Splice the "PARK" wire from the plug-in harness into the vehicle parking light wire following the recommended splicing procedure.

6. Cable tie the vehicle control harness, vehicle lighting harness, and plug-in harness away from any sharp, hot or moving parts.

TURN SIGNAL CONFIGURATION PLUG

⚠ WARNING

If the turn signal configuration plug is mated incorrectly, the turn signals will be reversed between the vehicle and the snowplow.

1. Mate the turn signal configuration plug located on the plug-in harness.

If the isolation module is installed on the driver's side, mate the plug so that the wire colors match (green to green and blue to blue).

If the module is installed on the passenger's side, mate the plug so that the wire colors are opposite (green to blue).

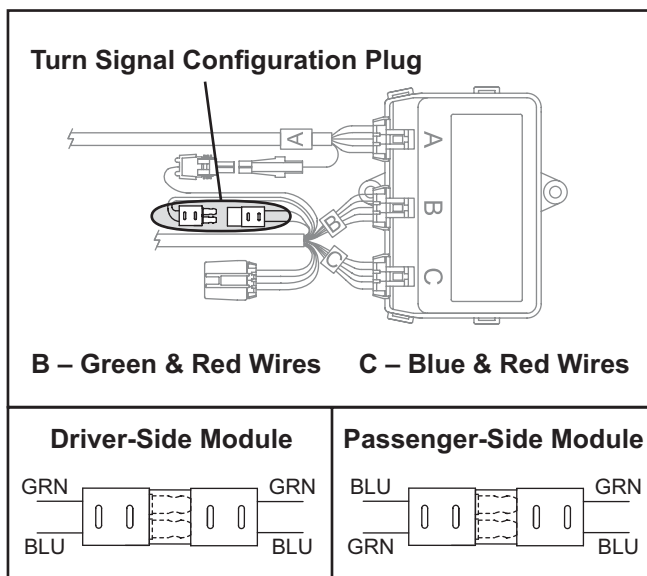

2. **GMC and Chevy vehicles only:** The pink wires and plugs on the 69817 plug-in harness are not used. Align plugs so that the single pink wire connects to the wire labeled "DRL1" and plug them together.
Not included on all harnesses.

BATTERY CONNECTIONS

NOTE: Cable tie the control harness and accessory tap away from the brake, clutch, gas or parking brake pedals, and any moving parts.

1. Attach the POSITIVE (+) OEM cable to the battery. Attach the RED vehicle battery cable to the POSITIVE (+) battery terminal following OEM battery cable connection recommendations.
2. Attach the NEGATIVE (–) OEM cable to the battery. Attach the BLACK vehicle battery cable to the NEGATIVE (–) battery terminal following OEM battery cable connection recommendations.

LOW-BEAM ALERT MESSAGE (69804 Harness Kit Only)

During the vehicle lighting check, with the snowplow installed, the dashboard message center may display a "Low Beam Headlight Out" alert when the headlamps are switched from low beam to high beam. This occurs because the snowplow utilizes a single bulb for both low- and high-beam modes. The low-beam lights will function normally, and the message can be disregarded.

RECOMMENDED SPLICING PROCEDURE

1. Locate wire to be spliced into.
2. Cut wire at least 1-1/2" from any other splice, connector, or terminal. If wires are covered by tubing or braid, remove enough of it to achieve the minimum clearance required.
3. Strip away 5/16" of insulation from the ends of the wires to be spliced.
4. Slide two wires into one end of the supplied parallel splice.
5. Place a piece of heatshrink tubing (3/16" x 1-1/4" long) over the remaining wire to be spliced. Cut tubing into 1-1/4" lengths if required.
6. Insert the wire into the open end of the splice and crimp using an appropriate crimp tool. One or two crimps may be necessary to ensure a good connection. No wire strands should be visible outside of the splice.
7. Preheat a soldering tool for at least one minute to help promote even solder flow.
8. Apply heat to the splice. Avoid heating too close to the insulation. Apply solder to the wires. Use just enough solder to produce an even flow through the splice. **Use rosin core solder ONLY. Do not use acid core solder.**

NOTE: Avoid using an excessive amount of solder, as it can result in wicking. Wicking occurs when solder travels up the wire core. This may cause the wire to become stiff or brittle, which could lead to a broken or open circuit.

9. Check the circuits for continuity.
10. Cover the splice with heatshrink tubing. The tubing should extend beyond the splice on both sides.
11. Using a hot air source, starting in the center and working out to either side, apply heat until the tubing recovers and glue can be seen around the edges. Allow the tubing to cool before handling.

NOTE: The splices supplied will accommodate 18-gauge wires as shown. For larger gauge wires, cut the wire, strip the ends 3/8" to 1/2" and twist together. Apply solder to the splice and cover with heatshrink tubing.

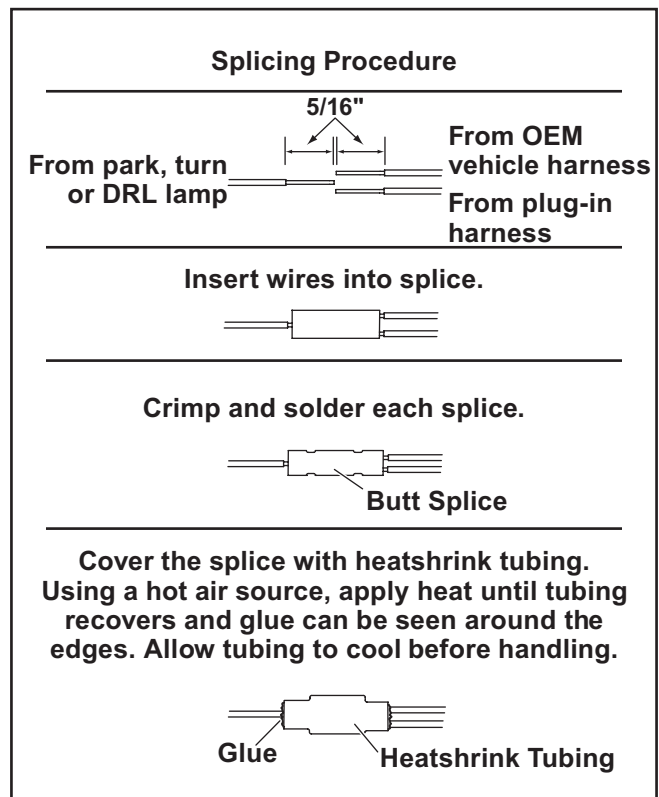

The company reserves the right under its product improvement policy to change construction or design details and furnish equipment when so altered without reference to illustrations or specifications used. This equipment manufacturer or the vehicle manufacturer may require or recommend optional equipment for snow removal. Do not exceed vehicle ratings with a snowplow. The company offers a limited warranty for all snowplows and accessories. See separately printed page for this important information.