

# **B29048, B29049, B29050, B29051, B29053, B29400-5**

## **HARNESS KIT 3-PORT ISOLATION MODULE LIGHT SYSTEM**

**w/2-PLUG SYSTEM HARNESSES**

### **Installation Instructions**

**⚠ CAUTION**

Read this document before installing the snowplow.

**⚠ CAUTION**

See your sales outlet/Web site for specific vehicle application recommendations before installation. The Undercarriage Selection Guide has specific vehicle and snowplow requirements.

**SAFETY DEFINITIONS**

**⚠ WARNING**

Indicates a potentially hazardous situation that, if not avoided, could result in death or serious personal injury.

**⚠ CAUTION**

Indicates a potentially hazardous situation that, if not avoided, may result in minor or moderate injury. It may also be used to alert against unsafe practices.

**NOTE:** Indicates a situation or action that can lead to damage to your snowplow and vehicle or other property. Other useful information can also be described.

**FUSES**

The snowplow electrical and hydraulic systems contain several blade-style automotive fuses. If a problem should occur and fuse replacement is necessary, the replacement fuse must be of the same type and amperage rating as the original. Installing a fuse with a higher rating can damage the system and could start a fire. Fuse Replacement, including fuse ratings and locations, is located in the Maintenance Section of the Owner's Manual.

**BATTERY SAFETY**

**⚠ CAUTION**



Batteries normally produce explosive gases, which can cause personal injury. Therefore, do not allow flames, sparks or lit tobacco to come near the battery. When charging or working near a battery, always cover your face and protect your eyes, and also provide ventilation.

- Batteries contain sulfuric acid, which burns skin, eyes and clothing.
- Disconnect the battery before removing or replacing any electrical components.

**TORQUE CHART**

**⚠ CAUTION**

Read instructions before assembling. Fasteners should be finger tight until instructed to tighten according to the torque chart. Use standard methods and practices when attaching snowplow, including proper personal protective safety equipment.

Recommended Fastener Torque Chart (ft-lb)			
Size	Torque		
	 SAE Grade 2	 SAE Grade 5	 SAE Grade 8
1/4-20	6	9	13
5/16-18	11	18	28
3/8-16	19	31	46
3/8-24	24	46	68
7/16-14	30	50	75
1/2-13	45	75	115
9/16-12	66	110	165
5/8-11	93	150	225
3/4-10	150	250	370
7/8-9	150	378	591
1-8	220	583	893
Metric Grade 8.8 (ft-lb)			
Size	Torque	Size	Torque
M 6	7	M 12	60
M 8	17	M 14	95
M 10	35	M 16	155
These torque values apply to fasteners except those noted in the instruction.			

TYPICAL 2-PLUG, 3-PORT MODULE SYSTEM DIAGRAM

**⚠ CAUTION**  
 On 2-Plug electrical systems, plug covers shall be used whenever snowplow is disconnected. Vehicle Battery Cable is 12-volt unfused source.

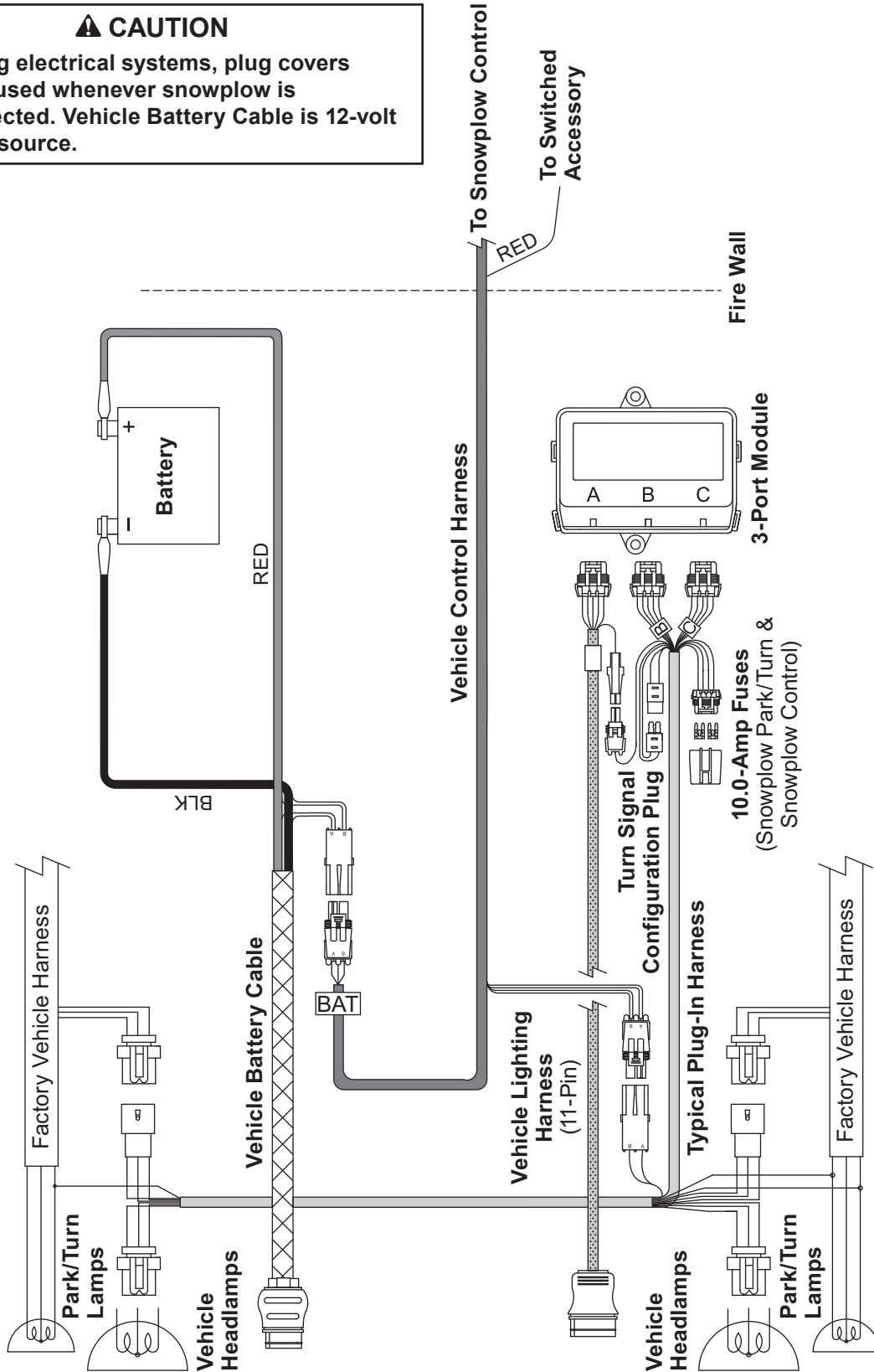

## VEHICLE BATTERY CABLE INSTALLATION

### **⚠ CAUTION**

Batteries normally produce explosive gases, which can cause personal injury. Therefore, do not allow flames, sparks or lit tobacco to come near the battery. When charging or working near a battery, always cover your face and protect your eyes, and also provide ventilation.

- Batteries contain sulfuric acid, which burns skin, eyes and clothing.
- Disconnect the battery before removing or replacing any electrical components.

---

**NOTE: When instructed, make all snowplow battery cable connections to the auxiliary battery, if vehicle is so equipped.**

---

1. Turn OFF the vehicle ignition.
2. Disconnect both the NEGATIVE (–) and the POSITIVE (+) battery cables.
3. Route the supplied vehicle battery cable from the grille or bumper to the battery, avoiding any sharp edges and hot or moving parts. Cable tie only the end section closest to the grille.
4. Route the red wire from the vehicle battery cable to the POSITIVE (+) battery terminal. Do not connect at this time.

---

**NOTE: Use dielectric grease on all electrical connections to prevent corrosion. Fill receptacles and lightly coat ring terminals before assembly.**

---

5. Route the black wire from the vehicle battery cable to the NEGATIVE (–) battery terminal. Do not connect at this time. The 4-position connector from the vehicle battery cable will connect to the mating connector (labeled "BAT") on the end of the vehicle control harness.

## ISOLATION MODULE MOUNTING

### **⚠ CAUTION**

Before installing self-drilling screws or drilling mounting holes, check the selected mounting area for any wires, hoses or other obstructions.

Isolation Modules are sold separately. Check the Undercarriage Selection Guide for the correct module for your vehicle.

Locate a flat surface within the engine compartment of the vehicle for mounting the Isolation Module (on the driver's side if possible). For example, the fire wall, fender well or radiator shroud are possible mounting locations. If a flat surface cannot be located, cable tie the Isolation Module to existing brackets or harnessing. Reclosable fastener strips and cable ties are supplied for mounting the Isolation Module, but self-drilling screws can also be used. When using the reclosable fastener strips, the mounting surface must be free of dirt and grease.

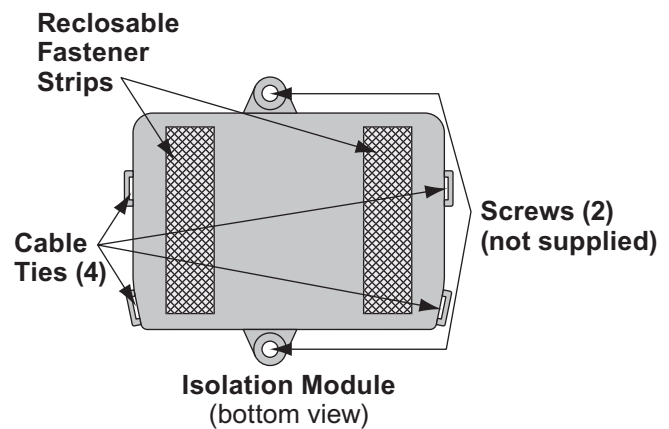

## **VEHICLE LIGHTING AND VEHICLE CONTROL HARNESS INSTALLATION**

1. Route the vehicle lighting harness around or through the radiator bulkhead to the Isolation Module.
2. Connect the vehicle lighting harness to position "A" on the 3-port Isolation Module.
3. Route the end of the vehicle control harness with the white, 4-pin connector to the fire wall.
4. Connect the black 4-position connector (labeled "BAT") from the end of the vehicle control harness to the 4-position connector from the vehicle battery cable. Do not cable tie the harness at this time.
5. On the driver's side, locate an existing hole through the fire wall for the vehicle control harness. If access through the fire wall does not exist, drill a 5/8" hole through the fire wall of the vehicle in a convenient location away from sharp edges and hot or moving parts.
6. Push the white 4-pin connector through the firewall hole into the cab. Use a grommet, existing plug cover or proper chafing material to protect the harness where it passes through the fire wall. Route the harness to the selected control mounting location. To mount the control, follow the instructions supplied with the control.
7. Locate an accessory wire controlled by the ignition switch. Acceptable accessory wires show +12V when the ignition switch is ON, and 0V when it is OFF.
8. Route the red "ACC" wire from the vehicle control harness to this location and trim away excess length.
9. Following the recommended splicing procedure, splice the red "ACC" wire into the switched accessory wire using the supplied parallel splices and heatshrink tubing.

**⚠ CAUTION**

**Before installing self-drilling screws or drilling mounting holes, check the selected mounting area for any wires, hoses or other obstructions.**

**RECOMMENDED SPLICING PROCEDURE**

1. Locate wire to be spliced into.
2. Cut wire at least 1-1/2" from any other splice, connector or terminal. If wires are covered by tubing or braid, remove enough of it to achieve the minimum clearance required.
3. Strip away 5/16" of the insulation from the ends of the wires to be spliced.
4. Slide two wires into one end of the supplied parallel splice.
5. Place a piece of heatshrink tubing (3/16" x 1-1/4" long) over the remaining wire to be spliced. Cut tubing into 1-1/4" lengths if required.
6. Insert wire into the open end of the splice and crimp using an appropriate crimp tool. One or two crimps may be necessary to ensure a good connection. No wire strands should be visible outside of the splice.
7. Preheat a soldering tool for at least one minute to help promote even solder flow.
8. Apply heat to the splice. Avoid heating too close to the insulation. Apply solder to the wires. Use just enough solder to produce an even flow through the splice. **Use rosin core solder ONLY. Do not use acid core solder.**

---

**NOTE: Avoid using an excessive amount of solder as it can result in wicking. Wicking occurs when solder travels up the wire core. This may cause the wire to become stiff or brittle which could lead to a broken or open circuit.**

---

9. Check circuits for continuity.
10. Cover the splice with heatshrink tubing. The tubing should extend beyond the splice on both sides.
11. Using a hot air source, starting in the center and working to either side, apply heat until the tubing recovers and glue can be seen around the edges. Allow the tubing to cool before handling.

---

**NOTE: The splices supplied will accommodate 18-gauge wires as shown. For larger gauge wires, cut the wire, strip the ends 3/8" to 1/2" and twist together. Apply solder to the splice and cover with heatshrink tubing.**

---

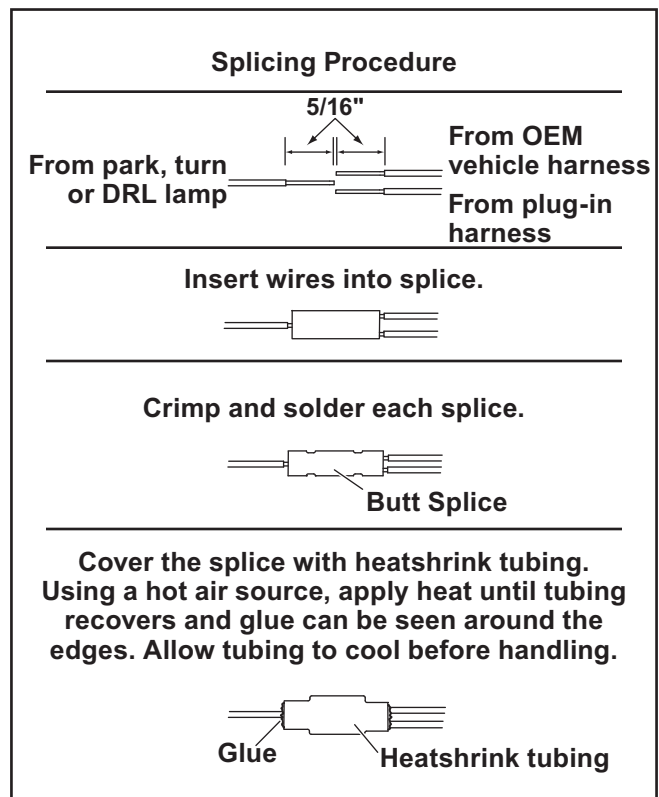

**PLUG COVER INSTALLATION**

1. Stretch the rectangular opening of a plug cover strap over the plug of the vehicle battery cable and over the plug of the vehicle lighting harness. Place the plug covers over the molded plugs when snowplow is not in use.

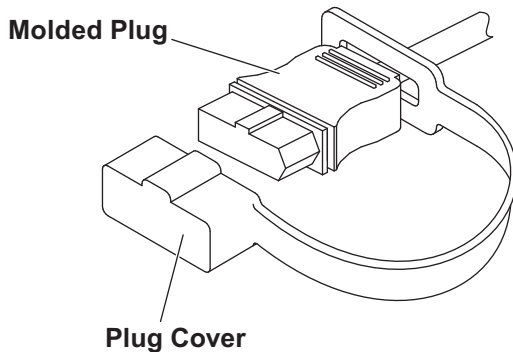

2. Secure the vehicle battery cable and vehicle lighting harness so they are protected when not in use and are easily retrieved for connection to the snowplow.

**PLUG-IN HARNESS INSTALLATION:  
ALL OTHER APPLICATIONS**

**For vehicles using the B29048 Harness Kit:** The plug-in harness contains 4 reversible 2-position connectors (2 gray and 2 black). The gray connectors connect to the low beams and the black connectors connect to the high beams.

**For vehicles using the B29400-5 Harness Kit:** The plug-in harness contains 4 reversible 2-position connectors. One set of connectors connects to the HB-3 bulbs and one set connects with the H11 bulbs.

**NOTE: To properly install reversible 2-position connectors, it is necessary to know which pin of the OEM headlamp connectors is common\*. When mating the OEM headlamp connectors with the plug-in harness, be sure to orient the connectors as shown below.**

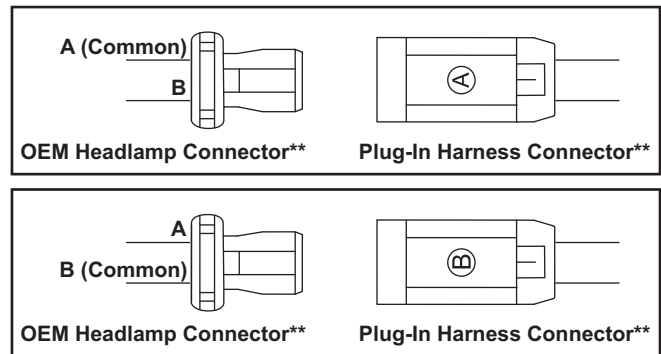

\*\* Connector appearance will vary.

**NOTE: DO NOT PROBE OR DAMAGE THE WIRE INSULATION. When the common wire is located the test lamp will illuminate.**

**Negative common** – a circuit that operates having a NEGATIVE (-) common will have ground to the load (headlamp, coil or motor relay) at all times. A switched 12V DC is required to complete and activate the circuit. Verify by connecting the test light lead to the battery's POSITIVE (+) terminal and test the OEM wires at the connector.

\* See A & B markings on the OEM headlamp connector for pin identification when testing for common.

**Positive common** – a circuit that operates having a POSITIVE (+) common will have 12V DC to the load (headlamp, coil or motor relay) at all times. A switched ground is required to complete and activate the circuit. Verify by connecting the test light lead to the battery's NEGATIVE (-) terminal and test the OEM wires at the connector.

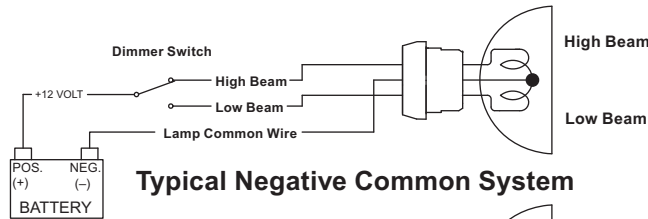

**Typical Negative Common System**

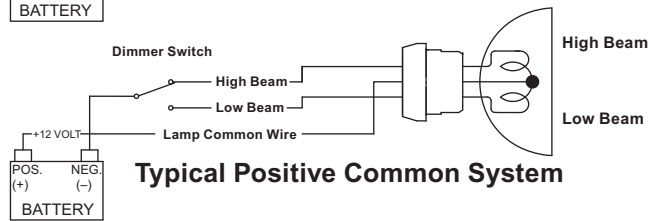

**Typical Positive Common System**

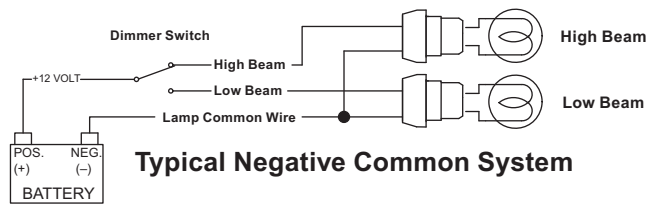

**Typical Negative Common System**

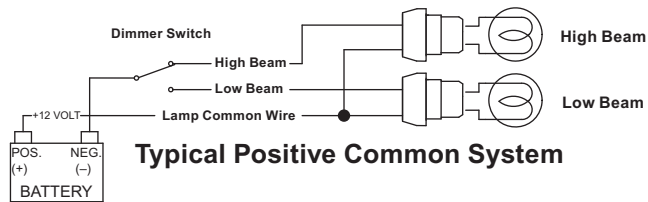

**Typical Positive Common System**

**For vehicles using the B29050 Harness Kit with HB-5 (9007) Headlamps:** Plug the vehicle headlamp connectors into plug-in harness with the locking tabs on the same side as the "HB-5" text.

**For vehicles using the B29050 Harness Kit with HB-1 (9004) Headlamps:** The B29050 harness comes from the factory configured for HB-5 (9007) headlamps. To convert this harness to HB-1 (9004) headlamps, first plug the vehicle headlamp connectors into the plug-in harness with the locking tabs on the same side as the "HB-1" text and, second, reverse the position of the low beam and common wires in the blue plug-in harness connector (move common wire to pin A and low beam wire to pin B).

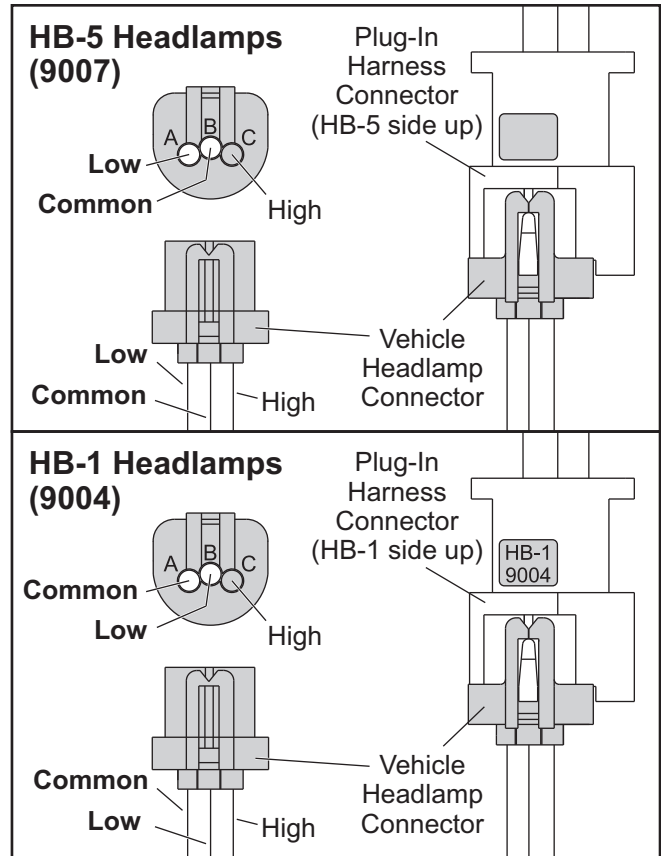

1. Remove the headlamp or headlamp housing connectors. Connect the plug-in harness to the mating connectors removed from the headlamps or headlamp housings.\* Connect the plug-in harness to the mating connections at the headlamps or headlamp housings. Route the plug-in harness to the 3-port Isolation Module. Connect the plug-in harness to the module by matching harness connector B with module port B and harness connector C with module port C.

\* For installations requiring an adapter, follow the instructions included with the adapter.



**For vehicles with dedicated DRL bulbs:**

Connect the DRL wire from the plug-in harness to the vehicle DRL bulb POSITIVE (+) wire.

**For vehicles with headlamp bulb or turn signal DRLs:** The DRL wire from the plug-in harness will not be used. Coil and cable tie the DRL wire.

2. Connect the black 4-position connector from the middle of the vehicle control harness to the 4-position connector from the plug-in harness.
3. If not already done during adapter installation, locate the turn signal wire on each side of the vehicle. Splice the "TURN" wire from the plug-in harness into the signal wire on the corresponding side following the recommended splicing procedure.
4. If not already done during adapter installation, splice the "PARK" wire from the plug-in harness into the parking light wire following the splicing procedure.
5. Cable tie the vehicle control harness, vehicle lighting harness and plug-in harness away from any sharp, hot or moving parts.

**TURN SIGNAL CONFIGURATION PLUG**

**⚠ WARNING**

**If the turn signal configuration plug is mated incorrectly, the turn signals will be reversed between the vehicle and the snowplow.**

1. Mate the turn signal configuration plug located on the plug-in harness. If the Isolation Module is installed on the driver's side, mate the plug so that the wire colors match (green to green and blue to blue). If the module is installed on the passenger's side, mate the plug so that the wire colors are opposite (green to blue).

**Turn Signal Configuration Plug**

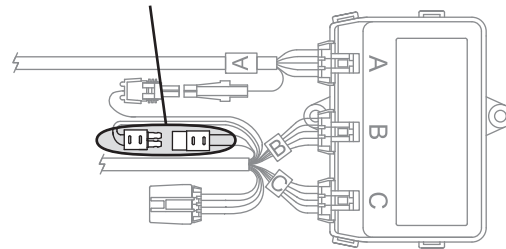

**B – Green & Red Wires    C – Blue & Red Wires**

**Driver-Side Module**

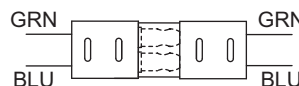

**Passenger-Side Module**

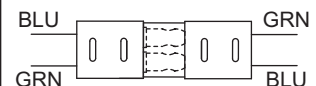

2. Connect the single-wire connector from the vehicle lighting harness to the single-wire connector from the plug-in harness.

## VEHICLE BATTERY CABLE INSTALLATION

### **⚠ CAUTION**

Batteries normally produce explosive gases, which can cause personal injury. Therefore, do not allow flames, sparks or lit tobacco to come near the battery. When charging or working near a battery, always cover your face and protect your eyes, and also provide ventilation.

- Batteries contain sulfuric acid, which burns skin, eyes and clothing.
- Disconnect the battery before removing or replacing any electrical components.

---

**NOTE:** When instructed, make all snowplow battery cable connections to the auxiliary battery, if vehicle is so equipped.

---

**NOTE:** For vehicles equipped with a tilt cab or tilt hood, a service loop will be necessary when making harness or cable transitions from the cab/hood to the frame. Check the cable installation for interference by raising and lowering the cab/hood a number of times. Add anti-chafing material (installer-supplied) as needed.

---

1. Turn OFF the vehicle ignition.
2. Disconnect both the NEGATIVE (–) and the POSITIVE (+) battery cables.
3. Route the supplied vehicle battery cable from the grille or bumper to the battery, avoiding any sharp edges and hot or moving parts. Cable tie only the end section closest to the grille. Lengthening the vehicle battery cable may be necessary on vehicles with batteries located under or behind the cab. If lengthening cables is necessary, use the

supplied isolated stud junction block. Mount the block to a flat surface within reach of the vehicle battery cable, and connect both the vehicle battery cable and the supplied 50" or 90" battery cable to the junction block.

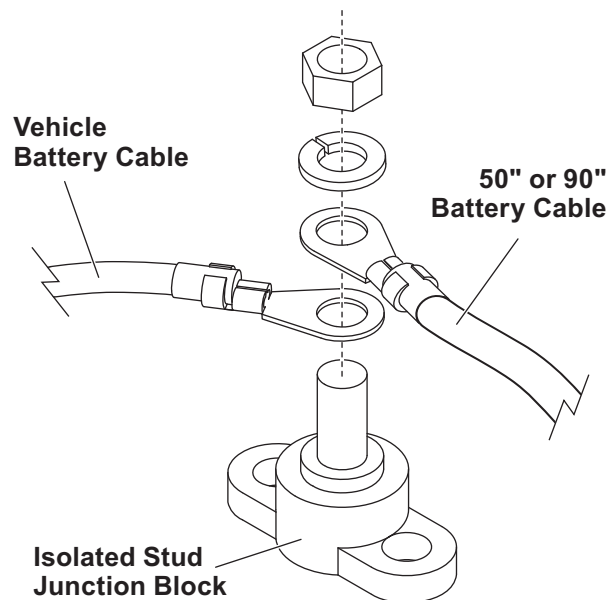

4. Route the red wire from the vehicle battery cable (or 50"/90" battery cable) to the POSITIVE (+) battery terminal. Do not connect at this time.

---

**NOTE:** Use dielectric grease on all electrical connections to prevent corrosion. Fill receptacles and lightly coat ring terminals and blades before assembly.

---

5. Route the black wire from the vehicle battery cable to the NEGATIVE (–) battery terminal. Do not connect at this time. On vehicles with the batteries located under or behind the cab, connect the black wire from the vehicle battery cable to the frame using an existing hole or ground bolt. Prior to attaching, clean away any paint or dirt to ensure a good ground connection. The 4-position connector from the vehicle battery cable will connect to the mating connector (labeled "BAT") on the end of the vehicle control harness.

## BATTERY CABLE CONNECTIONS

### Top Post Batteries w/Lead Cable Ends

1. Attach the POSITIVE (+) OEM cable to the battery post. Attach the red battery cable to the bolt in the OEM terminal with original fastener.
2. Attach the NEGATIVE (-) OEM cable to the battery post. Attach the black wire from the vehicle battery cable to the OEM terminal bolt with original fastener.

### Top Post Batteries w/Stamped Steel Battery Terminals

#### Top Post Batteries, Style One

These terminals are secured with a 6 mm washer-head cap screw and nut.

1. If the cap screw is long enough for the added thickness of the cable terminal, washer and nut, it will not need to be replaced and Step 2 may be skipped.
2. Carefully lift retainer tabs (if present) and remove the short cap screw. Insert the supplied longer cap screw through a 3/16" washer and into the hole in the clamp. Carefully bend the retainer tabs back into place.

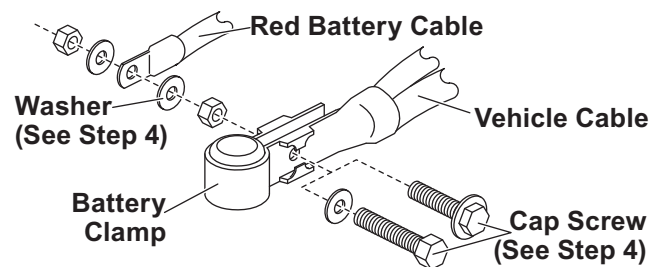

3. Attach POSITIVE (+) OEM battery clamp to battery post and secure clamp.
4. Place red battery cable over the end of the battery terminal screw. If added terminal has large contact area with the battery clamp, retain with washer and nut. If the terminal contact area is small (terminal hole almost passes over a 6 mm nut), add a washer to both sides of the cable and secure with a nut.

5. Connect the black wire from the vehicle battery cable and the OEM NEGATIVE (-) cable to the NEGATIVE (-) battery terminal following the same procedure used in Steps 1–4.

#### Top Post Batteries, Style Two

These terminals are secured with a 6 mm tapered nut and cam.

1. Make the connections to the POSITIVE (+) terminal as follows:
  - a. Remove cable assembly from battery post by loosening the nut. Trim plastic terminal cover as shown.

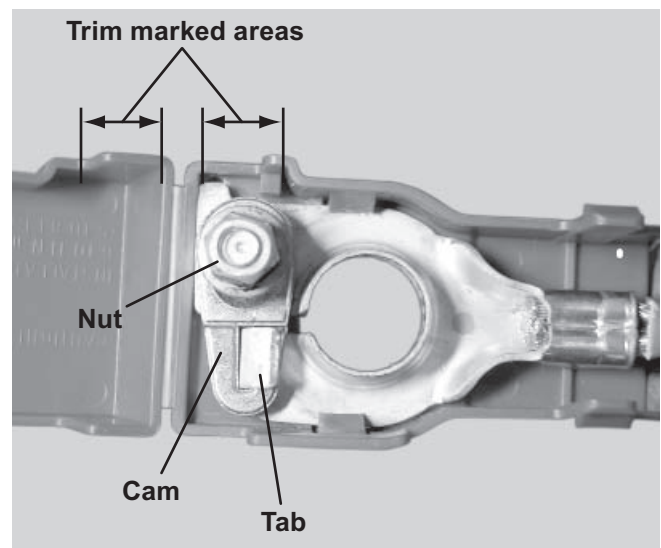

- b. Carefully bend tab securing the cam upward so the cam can be lifted off the stamped terminal after the nut has been removed.
- c. Place the red battery cable over the battery terminal screw.
- d. Slide the cam over the terminal screw and tab. Reinstall the nut.
- e. Place cable assembly on battery post, align red battery cable with the opening in the cover and tighten nut. Close plastic terminal cover.

2. Make the connections to the NEGATIVE (–) terminal as follows:
  - a. Remove cable assembly from battery post by loosening the nut.
  - b. Carefully bend tab securing the cam upward so the cam can be lifted off the stamped terminal after the nut has been removed.
  - c. Place the black wire from the vehicle battery cable over the battery terminal screw.
  - d. Slide the cam over the terminal screw and tab. Reinstall the nut.
  - e. Place cable assembly on battery post and tighten nut.

### **Top Post Batteries, Style Three**

These terminals are similar to Style Two, but do not have a visible cam or tab.

1. Make the connections to the POSITIVE (+) terminal as follows:
  - a. Remove cable assembly from battery post by removing the nut. Trim plastic terminal cover as necessary to accommodate the red snowplow battery cable.
  - b. Place the red battery cable over the battery terminal screw and reinstall the nut.
  - c. Place cable assembly on battery post, align red battery cable with the opening in the cover and tighten nut. Close plastic terminal cover.
2. Make the connections to the NEGATIVE (–) terminal as follows:
  - a. Remove cable assembly from battery post by removing the nut.
  - b. Place the black wire from the vehicle battery cable over the battery terminal screw and reinstall the nut.
  - c. Place cable assembly on battery post and tighten nut.

### **Side Terminal Batteries**

1. Use the furnished battery cable adapter to attach the red battery cable to the POSITIVE (+) terminal of the battery. Position the cable and tighten the adapter to 124–178 in-lb.
2. Connect the OEM POSITIVE (+) cable to the adapter on the battery. Position the cable and, while holding the adapter, tighten the battery cable bolt to 124–178 in-lb.
3. Connect the black wire from the vehicle battery cable and the OEM NEGATIVE (–) cable to the NEGATIVE (–) battery terminal following the same procedure used in Steps 1 and 2.



The company reserves the right under its product improvement policy to change construction or design details and furnish equipment when so altered without reference to illustrations or specifications used. This equipment manufacturer or the vehicle manufacturer may require or recommend optional equipment for snow removal. Do not exceed vehicle ratings with a snowplow. The company offers a limited warranty for all snowplows and accessories. See separately printed page for this important information.

**Printed in U.S.A.**

---