



RUBBER DEFLECTOR KIT

7600HD, 8000HD, 8600HD & 9000HD

Straight Blade Snowplows

PARTS LIST

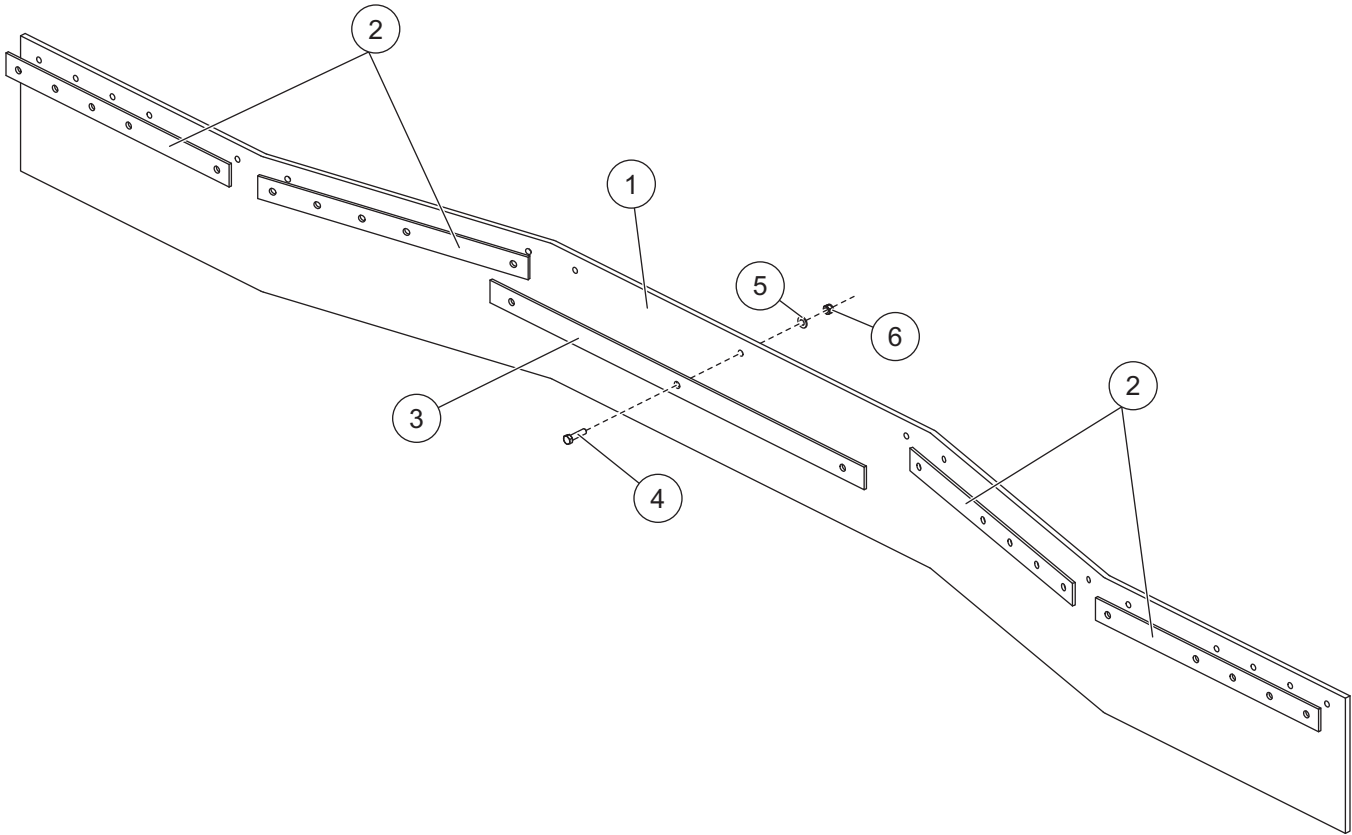

40700 Rubber Deflector Kit							
Item	Part	Qty	Description	Item	Part	Qty	Description
1	40685	1	Rubber Deflector	3	40683	1	Hold Down, Center
2	40684	4	Hold Down, Outer	ns	41181	1	Bolt Bag
41181 Bolt Bag							
4	90048	11	5/16-18 x 1-1/4 Hex Cap Screw G5	6	91332	11	5/16-18 Hex Locknut GB
5	B61412	11	5/16 Hardened Flat Washer				
ns = not shown				G = Grade			

⚠ WARNING

Do not exceed GVWR or GAWR, including blade and ballast. The rating label is found on the driver-side vehicle door cornerpost.

⚠ CAUTION

Read this document before installing the Rubber Deflector Kit.

INSTALLATION INSTRUCTIONS

⚠ CAUTION
 Use standard methods and practices when attaching snowplow and installing accessories including proper personal protective safety equipment.

⚠ CAUTION
 See your sales outlet for specific vehicle application recommendations before installation. Rubber Deflector Kit weight information may be found in the Undercarriage Selection Guide.

1. Park the vehicle on a smooth, level, hard surface, such as concrete. Lower the blade to the ground, and turn the control to the "OFF" position. Disconnect the snowplow from the vehicle, or turn the vehicle ignition to the "OFF" position and remove the key.
2. **For 7-1/2', 8' and 8-1/2' blades only:** Trim off both ends of the rubber deflector and the outside end of the two outermost hold-down bars, as shown below.

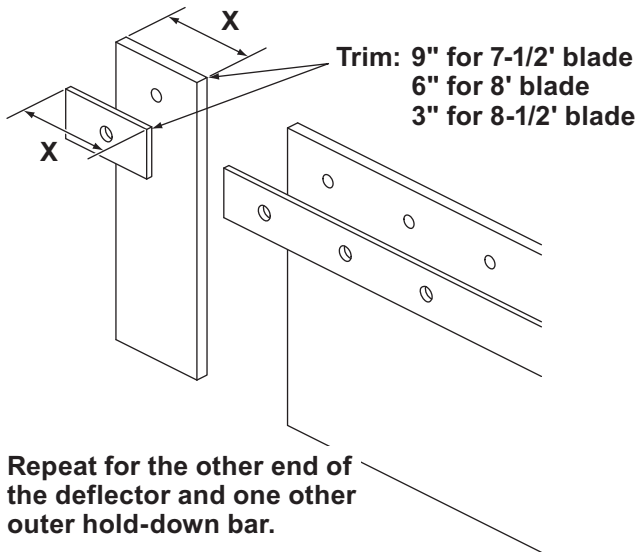

3. Align the center hole in the deflector with the center hole in the top of the moldboard. Place the center hold-down bar on top of the deflector, making sure the center holes are aligned, and secure with three 5/16" x 1-1/4" cap screws, washers and locknuts.

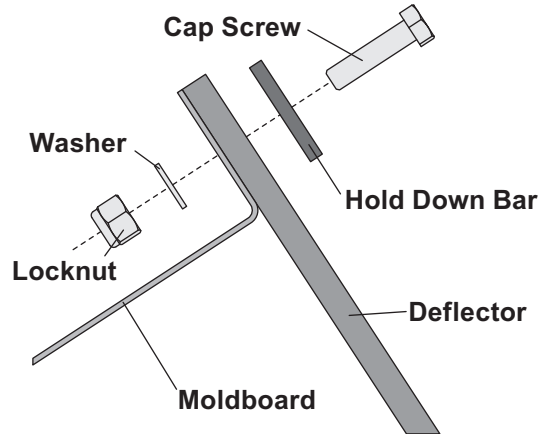

4. Secure the deflector with the remaining hold-down bars and fasteners. When more than two holes are available in the hold-down bar, use the outermost holes.
5. Tighten all fasteners to 18 ft-lb.

Copyright © 2009 Douglas Dynamics, L.L.C. All rights reserved. This material may not be reproduced or copied, in whole or in part, in any printed, mechanical, electronic, film or other distribution and storage media, without the written consent of Blizzard. Authorization to photocopy items for internal or personal use by the Blizzard outlets or snowplow owner is granted.

Blizzard reserves the right under its product improvement policy to change construction or design details and furnish equipment when so altered without reference to illustrations or specifications used. Blizzard or the vehicle manufacturer may require or recommend optional equipment for snow removal. Do not exceed vehicle ratings with a snowplow. Blizzard offers a limited warranty for all snowplows and accessories. See separately printed page for this important information. The following are registered (®) or unregistered (™) trademarks of Douglas Dynamics, L.L.C.: BLIZZARD®.