

SINGLE- AND DOUBLE-ACTING RAM SEALS

INSTALLATION INSTRUCTIONS

For single-acting rams:

1. Lubricate O-rings before assembly. Narrow O-ring is for the cylinder groove.
2. Assemble gland components as shown, then lubricate.

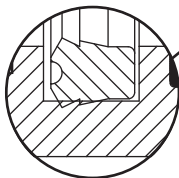
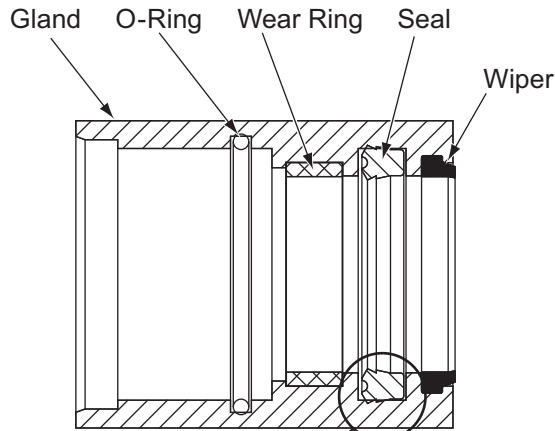

Seal Position

3. Remove bearing carrier and assemble gland to threaded end of rod. Do not slide gland over cross hole in rod.

4. Reassemble bearing carrier and tighten nut to 100–120 ft-lb. Assemble new wear ring on bearing carrier.

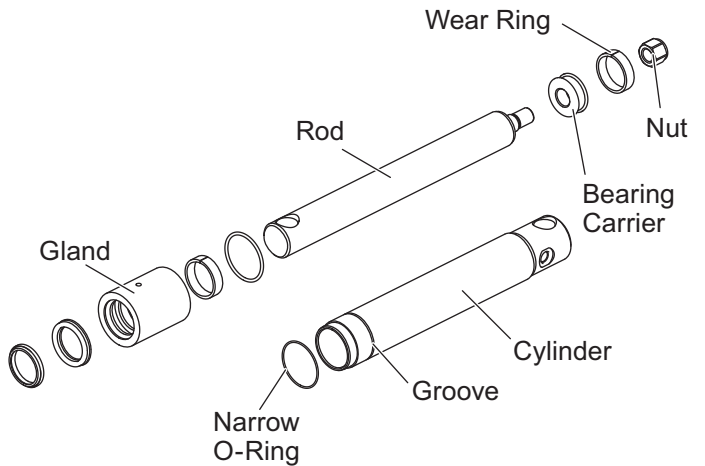

5. Assemble O-ring in cylinder groove and apply bead of medium-strength threadlocker all around threads of cylinder.
6. Slide rod assembly into cylinder and tighten gland to 30–40 ft-lb.

SINGLE- AND DOUBLE-ACTING RAM SEALS

For double-acting rams:

1. Lubricate O-rings before assembly.
2. Assemble gland components as shown, then lubricate.

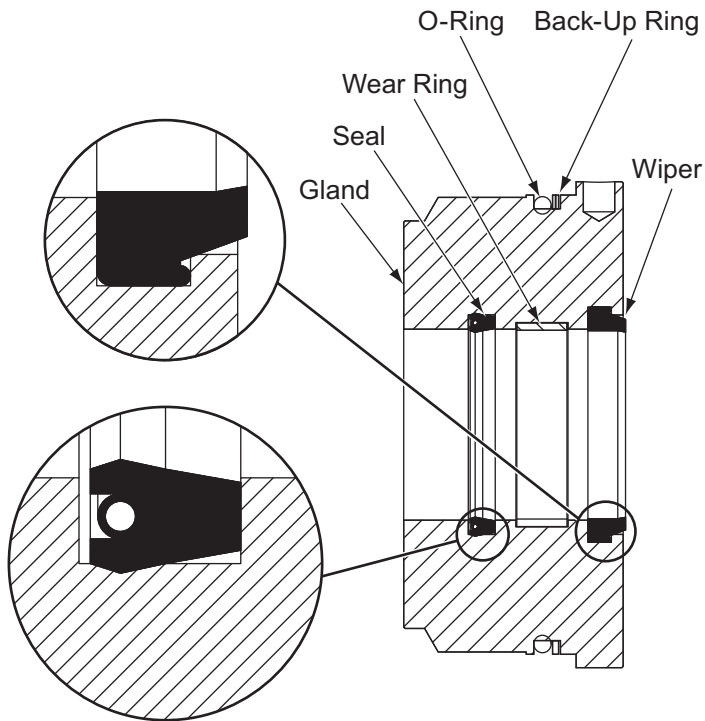

Seal Position

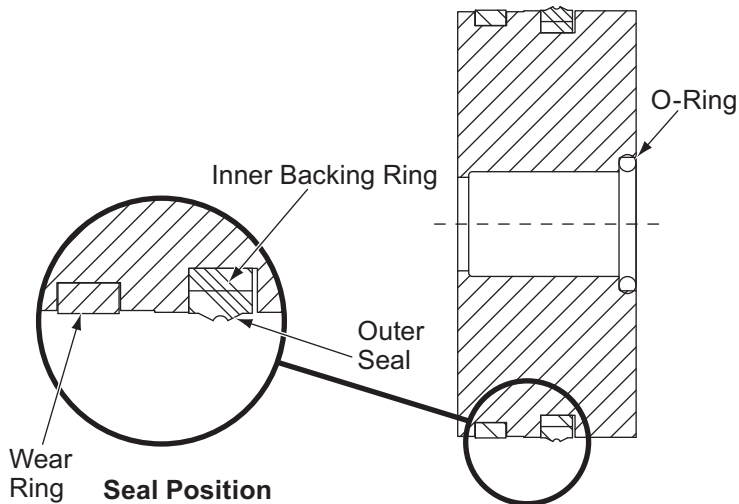

Seal Position

3. Remove piston from rod and assemble piston components as shown.

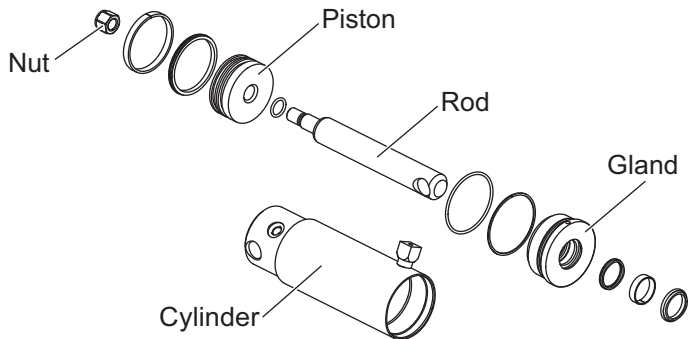

4. Assemble gland to threaded end of rod. Do not slide gland over cross hole in rod.
5. Reassemble piston to rod and tighten nut to 100–120 ft-lb.
6. Apply bead of medium-strength threadlocker all around threads of gland.
7. Lubricate piston seals and inside of cylinder.
8. Press rod assembly into cylinder and tighten gland to 30–40 ft-lb.

The company reserves the right under its product improvement policy to change construction or design details and furnish equipment when so altered without reference to illustrations or specifications used.

Printed in U.S.A.