

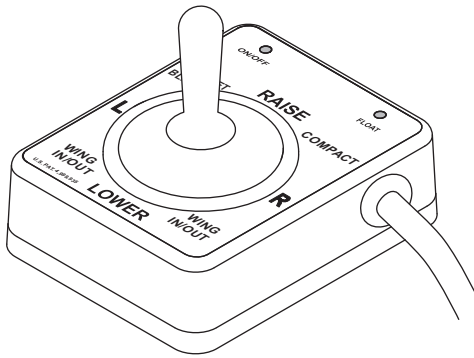

CONTROL KITS

POWER PLOW® Joystick Control

INSTALLATION INSTRUCTIONS



⚠ CAUTION

Read this document before installing the snowplow.

⚠ CAUTION

Use standard methods and practices when attaching snowplow and installing accessories including proper personal protective safety equipment.

SAFETY DEFINITIONS

⚠ WARNING

Indicates a potentially hazardous situation that, if not avoided, could result in death or serious personal injury.

⚠ CAUTION

Indicates a potentially hazardous situation that, if not avoided, may result in minor or moderate injury. It may also be used to alert against unsafe practices.

NOTE: Indicates a situation or action that can lead to damage to your snowplow and vehicle or other property. Other useful information can also be described.

FUSES

The BLIZZARD® electrical and hydraulic systems contain several automotive blade-style fuses. If a problem should occur and fuse replacement is necessary, the replacement fuse must be of the same type and amperage rating as the original. Installing a fuse with a higher rating could damage the system and could start a fire. Fuse Replacement, including fuse ratings and locations, is located in the Maintenance Section of the Owner's Manual.

NOTE: The controls (4-pin connector) do not contain on-board fuses. Consult your snowplow Owner's Manual for fuse replacement. Fuses are located both under the hood and on the hydraulic unit.

CONTROL PLACEMENT

⚠ CAUTION

Do not alter, modify or install additional components in shaded areas of the illustration below. Failure to comply may interfere with air bag deployment or cause injury to operator in an accident.

When choosing a location for your control, it should be mounted in easy reach of the vehicle operator and not restricting access to vehicle controls or vehicle instrumentation. Do not mount the control in areas prohibited by the vehicle manufacturer for crash worthiness. See the vehicle's body builders book, owner's manual, or service manual for details. The shaded areas in the illustration below show the most commonly restricted areas.

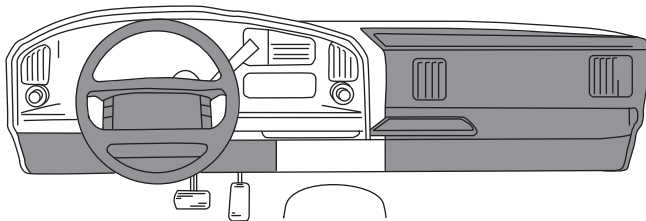

INSTALLING DASH BRACKET

⚠ CAUTION

Before drilling holes, check to be sure that no vehicle wiring or other components could be damaged.

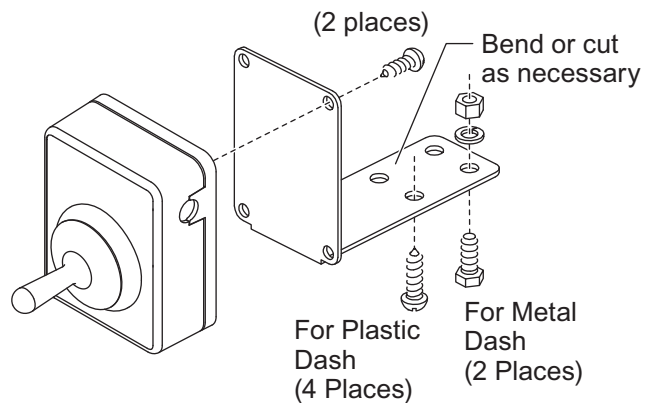

Plastic Dash Only:

1. Using the four clearance holes on the narrow end of the bracket as guides, drill four 9/64" tap holes in the dash.
2. Attach the bracket to the dash with four #12 x 3/4" self-tapping screws.

Metal Dash Only:

1. Using two of the four clearance holes on the narrow end of the bracket as guides, drill two 9/32" holes in the dash.
2. Attach the control to the control bracket with two #8 x 5/8" self-tapping screws, or with the PRO-GRIP Mount Kit (PN 49305K) as instructed.
3. Attach the bracket to the dash with two 1/4" x 3/4" cap screws, 1/4" lock washers and 1/4" nuts.

PRO-GRIP MOUNT KIT

The PRO-GRIP Mount Kit will secure your BLIZZARD® joystick control to the interior vehicle cab surfaces. Possible mounting areas may include the front or side of the dash, center console, etc. Location will depend on operator preference and mounting clearance with other vehicle controls. Once the control is properly mounted, it can be easily removed and stored.

Installation should be done at temperatures above 60°F (15.6°C).

1. Select the area of the cab where the control will be mounted.
2. Clean the installation area and the surface of control with isopropyl alcohol or mineral spirits. Allow the surface to dry for 15 minutes.
3. Determine the length of the dual locking strip required. **Do not obstruct the ON/OFF switch.**

For flat surfaces: Use full-length locking strips mounted along the length of the control. Strips may be placed on the back of the side of the control.

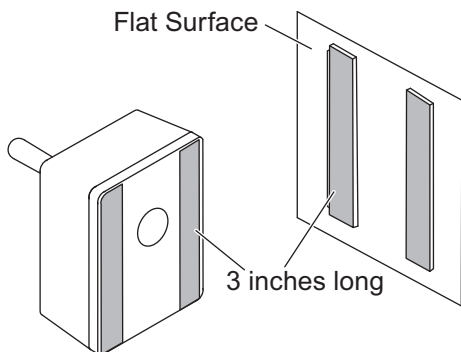

For curved surfaces: Cut the locking strips to 2 inches. These strips must be placed parallel to the curved surface.

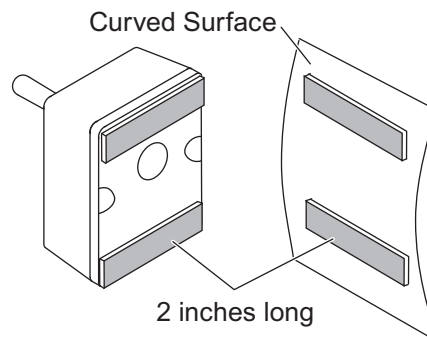

4. Once the selected surfaces are prepared, remove the adhesive back protection strip and press the locking strips into place. Apply pressure across the entire surface to work out any trapped air bubbles.
5. Allow the locking strip adhesive to set for 24 hours before mounting the control to the cab surface.

The control can be easily removed by applying a sideways lifting motion to the control. Do not apply excessive force. If the control does not release, gently pry up in the opening under the control with a screwdriver or other flat object.

The PRO-GRIP locking strips can be removed from control and mounting location if no longer needed. Adhesive residue can be cleaned up with mineral spirits.

Blizzard reserves the right under its product improvement policy to change construction or design details and furnish equipment when so altered without reference to illustrations or specifications used. Blizzard or the vehicle manufacturer may require or recommend optional equipment for snow removal. Do not exceed vehicle ratings with a snowplow. Blizzard offers a limited warranty for all snowplows and accessories. See separately printed page for this important information. The following are registered (®) or unregistered (™) trademarks of Douglas Dynamics, L.L.C.: BLIZZARD®, BUCKET BLADE™, POWER PLOW®.

Printed in U.S.A.
